

YAMAHA

DT175D '92

3FJ-ME1

SERVICE MANUAL

DT175D
SERVICE MANUAL
©1991 by Yamaha Motor Co., Ltd.
1st Edition, August 1991
All rights reserved. Any reprinting or
unauthorized use without the written
permission of Yamaha Motor Co., Ltd.
is expressly prohibited.

NOTICE

This manual was written by the Yamaha Motor Company primarily for use by Yamaha dealers and their qualified mechanics. It is not possible to put an entire mechanic's education into one manual, so it is assumed that persons using this book to perform maintenance and repairs on Yamaha motorcycle have a basic understanding of the mechanical concepts and procedures inherent in motorcycle repair technology. Without such knowledge, attempted repairs or service to this model may render it unfit to use and/or unsafe.

Yamaha Motor Company, Ltd. is continually striving to improve all models manufactured by Yamaha. Modifications and significant changes in specifications or procedures will be forwarded to all Authorized Yamaha dealers and will, where applicable, appear in future editions of this manual.

PARTICULARLY IMPORTANT INFORMATION

This material is distinguished by the following notation.



The Safety Alert Symbol means ATTENTION! BECOME ALERT! YOUR SAFETY IS INVOLVED!

WARNING

Failure to follow WARNING instructions could result in severe injury or death to the motorcycle operator, a bystander, or a person inspecting or repairing the motorcycle.

CAUTION:

A CAUTION indicates special precautions that must be taken to avoid damage to the motorcycle.

NOTE:

A NOTE provides key information to make procedures easier or clearer.

HOW TO USE THIS MANUAL

CONSTRUCTION OF THIS MANUAL

This manual consists of chapters for the main categories of subjects. (See "Illustrated symbols")

- 1st title ① : This is a chapter with its symbol on the upper right of each page.
- 2nd title ② : This title appears on the upper of each page on the left of the chapter symbol. (For the chapter "Periodic inspection and adjustment" the 3rd title appears.)
- 3rd title ③ : This is a final title.

MANUAL FORMAT

All of the procedures in this manual are organized in a sequential, step-by-step format. The information has been compiled to provide the mechanic with an easy to read, handy reference that contains comprehensive explanations of all disassembly, repair, assembly, and inspections. A set of particularly important procedure ④ is placed between a line of asterisks "*" with each procedure preceded by "●".

IMPORTANT FEATURES

- Data and a special tool are framed in a box preceded by a relevant symbol ⑤.
- An encircled numeral ⑥ indicates a part name, and an encircled alphabetical letter data or an alignment mark ⑦, the others being indicated by an alphabetical letter in a box ⑧.
- A condition of a faulty component will precede an arrow symbol and the course of action required the symbol ⑨.

EXPLODED DIAGRAM

Each chapter provides exploded diagrams before each disassembly section for ease in identifying correct disassembly and assembly procedures.

①

②

③

⑤

④

INSPECTION AND REPAIR ENG

2. Remove
 * Crankshaft: ②
 Use the crankcase separating tool ①.

Crankcase separating tool ①
 YU-4158

INSPECTION AND REPAIR
CYLINDER HEAD

1. Remove
 * Carbon deposits
 Use a rounded scraper

NOTE:
 Take care to avoid damaging the work shop
 surface. Do not use a sharp instrument.
 Avoid scratching the aluminum.

2. Measure
 * Cylinder head warpage
 Out of specification → Resurface

Warpage tool
 5-82 mm (2.091 in)

Warpage measurement and resurfacing
 step

③ Attach a straight edge ① and a machin-
 er's level ② on the cylinder head.

④ Measure the warpage.

⑤ If the warpage is out of specification, re-
 surface the cylinder head.

⑥ Place a 400- 500 grit wet sandpaper on
 the surface plate, and resurface the head
 using a figure-eight sanding pattern.

NOTE:
 Rub the head several times to avoid re-
 moving too much material from one side.

FRONT FORK CHAS

INSPECTION

1. Inspect
 * Front fork tube ①
 * Outer fork tube ②
 Scratches/Scratches/Damage → Replace

WARNING
 Do not attempt to straighten a bent lower
 fork tube or this may dangerously weaken
 the tube.

2. Inspect
 * Dust seal
 * Greasener
 Scratches/Damage → Replace

3. Measure
 * Fork spring free length ③
 Out of specification → Replace

Fork spring free length
 4 95.5 mm (19.5 in)
 Minimum free length
 4 92 mm (19.1 in)

4. Install
 * Drive chain
 * Jam drive chain
 * Cap drive chain

WARNING
 Make sure that the sprocket ④ is installed in the
 correct direction. Otherwise, the drive
 chain will be damaged.

⑤ Tighten sprocket
 ⑥ Lubricate
 * Drive chain



















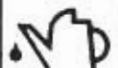

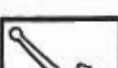
Chain lube
 Yamaha chain lube or
 equivalent

⑥

⑨

⑦

⑧

| | |
|--|---|
| ① GEN INFO  | ② SPEC  |
| ③ INSP ADJ  | ④ ENG  |
| ⑤ COOL  | ⑥ CARB  |
| ⑦ CHAS  | ⑧ ELEC  |
| ⑨ TRBL SHTG ? | ⑩  |
| ⑪  | ⑫  |
| ⑬  | ⑭  |
| ⑮  | ⑯  |
| ⑰  | ⑱  |
| ⑲  | ⑳  |
| ㉑  | ㉒  |
| ㉓  | |

ILLUSTRATED SYMBOLS (Refer to the illustration)

Illustrated symbols ① to ⑨ are designed as thumb tabs to indicate the chapter's number and content.

- ① General information
- ② Specifications
- ③ Periodic inspection and adjustment
- ④ Engine
- ⑤ Cooling system
- ⑥ Carburetion
- ⑦ Chassis
- ⑧ Electrical
- ⑨ Troubleshooting





Illustrated symbols ⑩ to ⑯ are used to identify the specifications appearing in the text.

- ⑩ Filling fluid
- ⑪ Lubricant
- ⑫ Special tool
- ⑬ Tightening
- ⑭ Wear limit, clearance
- ⑮ Engine speed
- ⑯ Ω , V, A

Illustrated symbols ⑰ to ㉓ in the exploded diagram indicate grade of lubricant and location of lubrication point.

- ⑰ Apply engine oil
- ⑱ Apply gear oil
- ⑲ Apply molybdenum disulfide oil
- ⑳ Apply wheel bearing grease
- ㉑ Apply lightweight lithium-soap base grease
- ㉒ Apply molybdenum disulfide grease
- ㉓ Apply locking agent (LOCTITE®)

INDEX

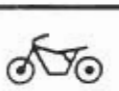
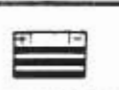
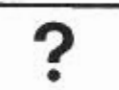
| | |
|---------------------------------------|---|
| GENERAL INFORMATION |  |
| | GEN INFO 1 |
| SPECIFICATIONS |  |
| | SPEC 2 |
| PERIODIC INSPECTION AND ADJUSTMENT |  |
| | INSP ADJ 3 |
| ENGINE OVERHAUL |  |
| | ENG 4 |
| CARBURETION |  |
| | CARB 5 |
| CHASSIS |  |
| | CHAS 6 |
| ELECTRICAL |  |
| | ELEC 7 |
| TROUBLESHOOTING |  |
| | TRBL SHTG 8 |

CHAPTER 1. GENERAL INFORMATION

| | |
|---|---------|
| MOTORCYCLE IDENTIFICATION | A-8 |
| VEHICLE IDENTIFICATION NUMBER (For AUS) | A-8 |
| FRAME SERIAL NUMBER (Except for AUS) | A-8 |
| ENGINE SERIAL NUMBER | A-8 |
| IMPORTANT INFORMATION | A-8 |
| PREPARATION FOR REMOVAL | A-8 |
| ALL REPLACEMENT PARTS | A-9 |
| GASKETS, OIL SEALS, AND O-RINGS | A-9 |
| LOCK WASHERS/PLATES AND COTTER PINS | A-9 |
| BEARINGS AND OIL SEALS | A-9 |
| CIRCLIPS | A-9 |
| SPECIAL TOOLS | A-9 |
| FOR TUNE UP | A-9 |
| FOR ENGINE SERVICE | A-10 |
| FOR CHASSIS SERVICE | A-10 |
| FOR ELECTRICAL COMPONENTS | A-11 |

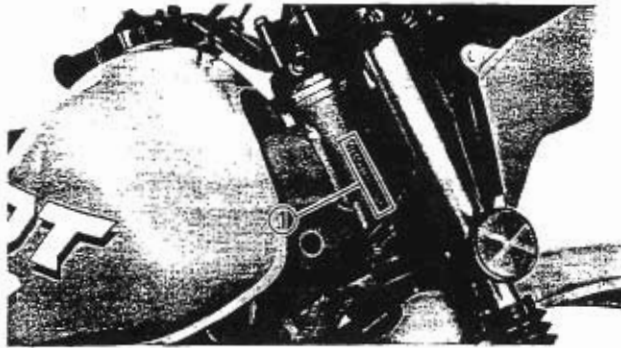

GENERAL INFORMATION

**MOTORCYCLE IDENTIFICATION
VEHICLE IDENTIFICATION NUMBER
(For AUS)**

The vehicle identification number ① is stamped into the steering head pipe.

Starting serial number:
JYA1EJT0*NA028101

NOTE:

The vehicle identification number is used to identify your motorcycle and may be used to register your motorcycle with the licensing authority in your state.

FRAME SERIAL NUMBER (Except for AUS)

The frame serial number ① is stamped into the right side of the steering head pipe.

Starting serial number:
1EJ-028101

ENGINE SERIAL NUMBER

The engine serial number ① is stamped into the elevated part of the right rear section of the engine.

Starting serial number:
1EJ-028101

NOTE:

- The first three digits of these numbers are for model identification; the remaining digits are the unit production number.
- Designs and specifications are subject to change without notice.

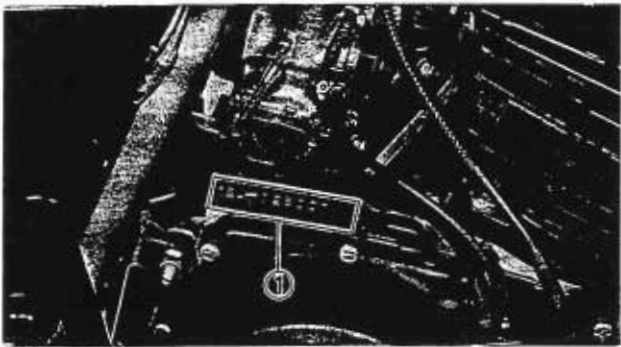



**IMPORTANT INFORMATION
PREPARATION FOR REMOVAL**

1. Remove all dirt, mud, dust, and foreign material before removal and disassembly.

2. Use proper tools and cleaning equipment. Refer to "SPECIAL TOOL".

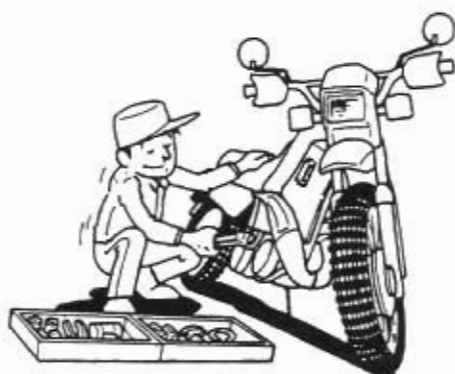

3. When disassembling the machine, keep mated parts together. This includes gears, cylinders, pistons, and other mated parts that have been "mated" through normal wear. Mated parts must be reused as an assembly or replaced.



4. During the machines disassembly, clean all parts and place them in trays in the order of disassembly. This will speed up assembly time and help assure that all parts are correctly reinstalled.



5. Keep away from fire.



ALL REPLACEMENT PARTS

1. Use only genuine Yamaha parts for all replacements. Use oil and/or grease recommended by Yamaha for assembly and adjustment. Other brands may be similar in function and appearance, but inferior in quality.

GASKETS, OIL SEALS, AND O-RINGS

1. All gaskets, seals, and O-rings should be replaced when an engine is overhauled. All gasket surfaces, oil seal lips, and O-rings must be cleaned.
2. Properly oil all mating parts and bearings during reassembly. Apply grease to the oil seal lips.

LOCK WASHERS/PLATES AND COTTER PINS

1. All lock washers/plates ① and cotter pins must be replaced when they are removed. Lock tab(s) should be bent along the bolt or nut flat(s) after the bolt or nut has been properly tightened.

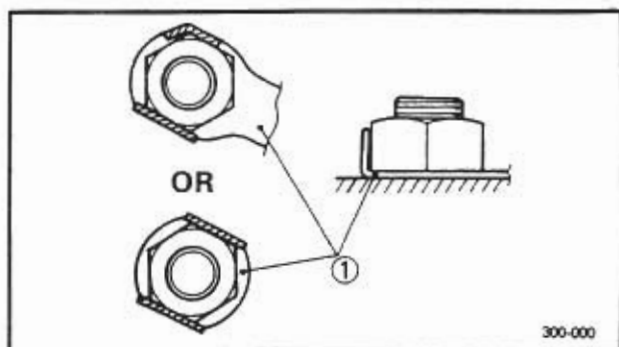

BEARINGS AND OIL SEALS

1. Install the bearing(s) and oil seal(s) with their manufacturer's marks or numbers facing outward. (In other words, the stamped letters must be on the side exposed to view.) When installing oil seal(s), apply a light coating of light-weight lithium base grease to the seal lip(s). Oil the bearings liberally when installing.

① Oil seal

CAUTION:

Do not use compressed air to spin the bearings dry. This causes damage to the bearing surfaces.

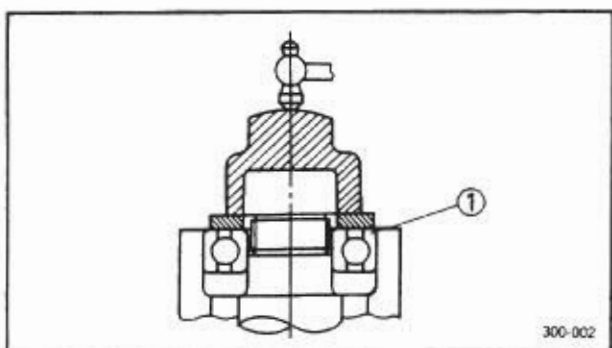
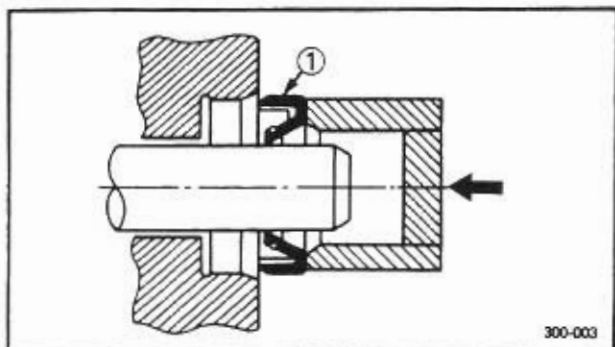

① Bearing

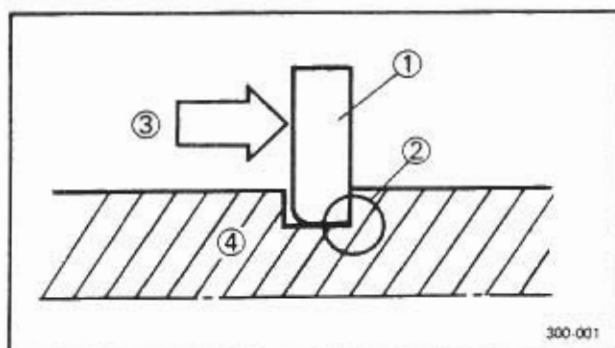
**CIRCLIPS**

1. All circlips should be inspected carefully before reassembly. Always replace piston pin clips after one use. Replace distorted circlips. When installing a circlip ①, make sure that the sharp edged corner ② is positioned opposite to the thrust ③ it receives. See the sectional view.

④ Shaft

SPECIAL TOOLS

The proper special tools are necessary for complete and accurate tune-up and assembly. Using the correct special tool will help prevent damage caused by the use of improper tools or improvised techniques.

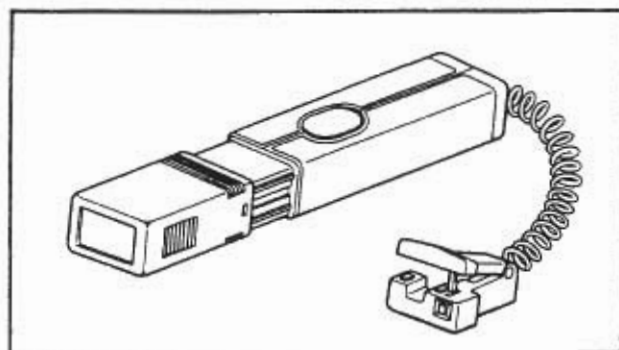
**FOR TUNE UP**

1. Inductive timing light
P/N. 90890-03141

This tool is necessary for checking ignition timing.

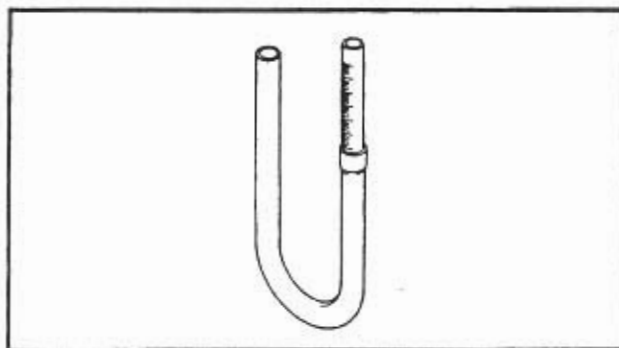

2. Fuel level gauge
P/N. 90890-01312

This gauge is used to measure the fuel level in the float chamber.

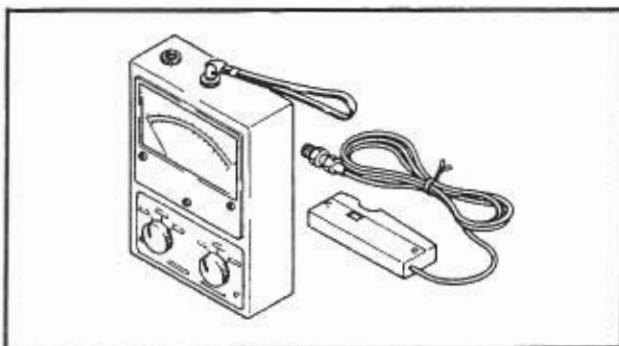

3. Inductive tachometer
P/N. 90890-03113

This tool is needed for detecting engine rpm.

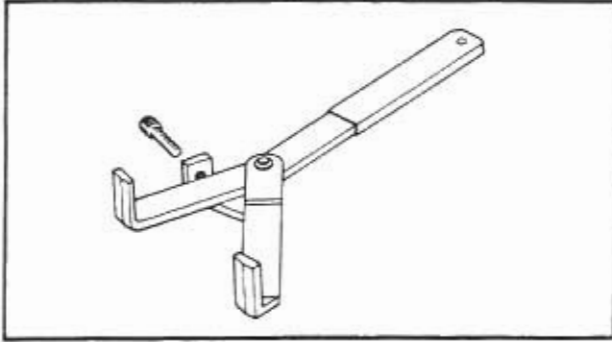
**FOR ENGINE SERVICE**

1. Universal clutch holder
P/N. 90890-04086

This tool is used to hold the clutch when loosening or tightening the clutch boss locknut.

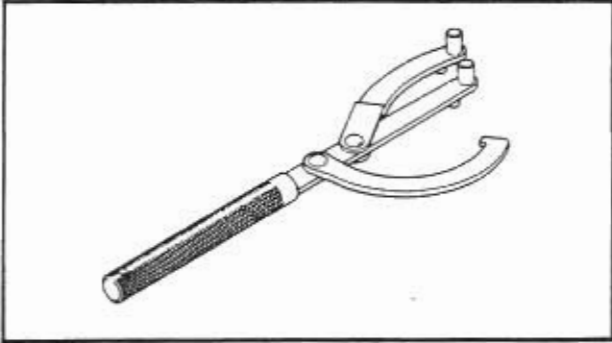

2. Universal rotor holder
P/N. 90890-01235

This tool is used when loosening or tightening the flywheel magneto securing bolt.

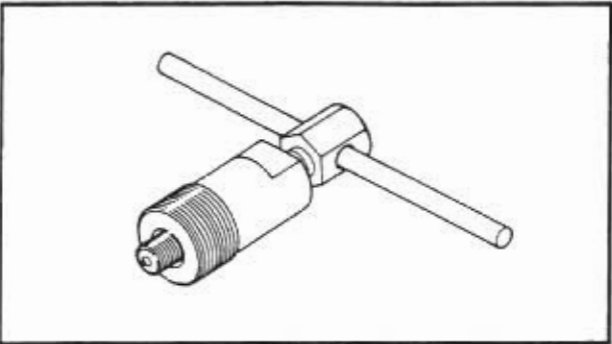

3. Flywheel puller
P/N. 90890-01189

This tool is used for removing the flywheel.

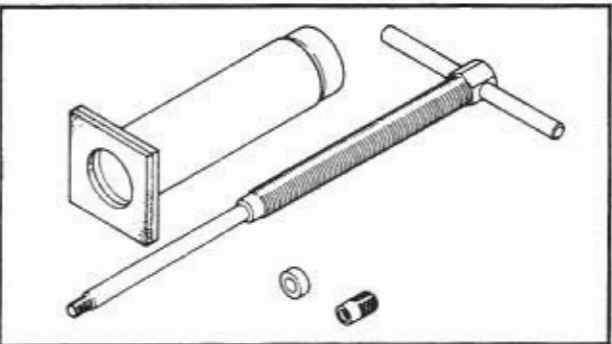

4. Piston pin puller
P/N. 90890-01304

This tool is used to remove the piston pin.

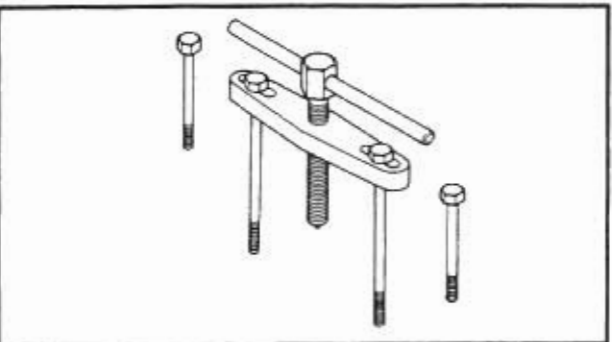

5. Crankcase separating tool
P/N. 90890-01135

This tool is used to remove the crankshaft or separate the crankcase.

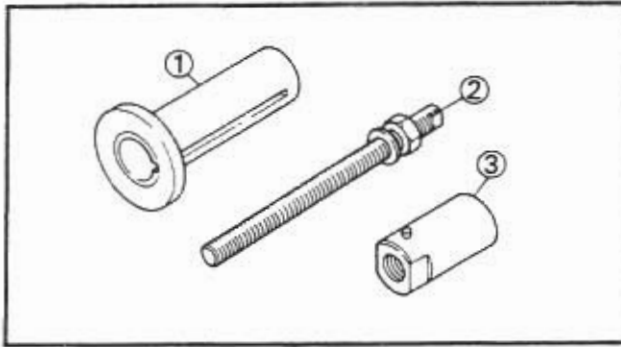

6. Crankshaft installing tool
 P/N. 90890-01274—①
 P/N. 90890-01275—②
 P/N. 90890-01278—③

These tools are used to install the crankshaft.

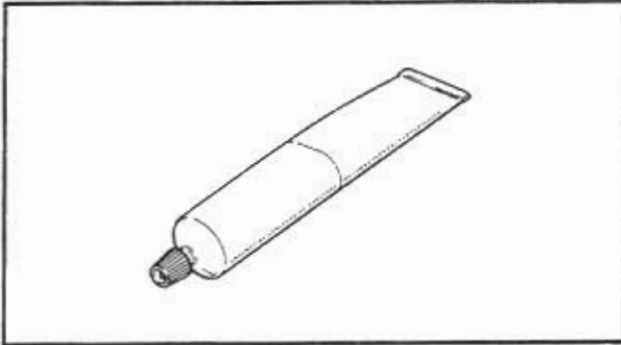

7. YAMAHA bond No. 1215
 P/N. 90890-85505

This sealant (bond) is used for crankcase mating surfaces, etc.

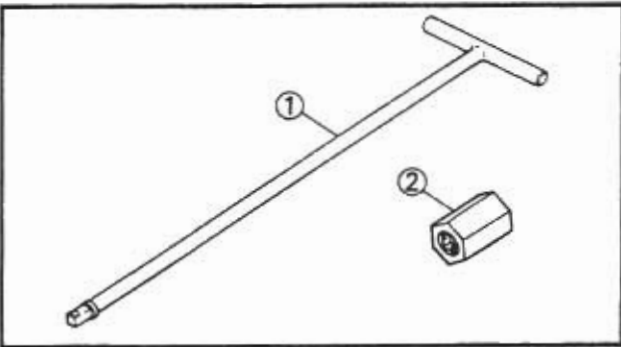

FOR CHASSIS SERVICE

1. T-handle—①
 P/N. 90890-01326
 Front fork cylinder holder—②
 P/N. 90890-04084

This tool is used to loosen and tighten the front fork cylinder holding bolt.

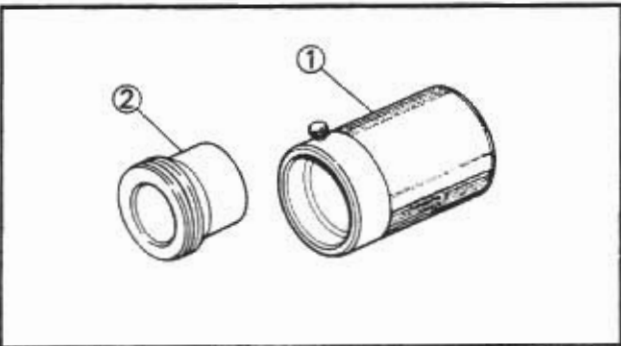

2. Front fork seal driver (weight)—①
 P/N. 90890-01367
 Adapter—②
 P/N. 90890-01372

These tools are used when installing the fork seal.

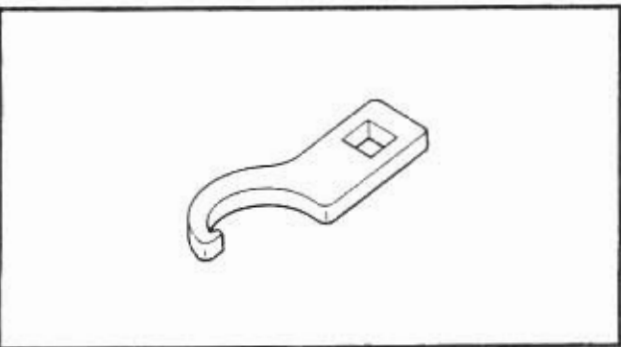

3. Ring nut wrench
 P/N. 90890-01403

This tool is used to loosen and tighten the steering ring nut.

**FOR ELECTRICAL COMPONENTS**

1. Ignition checker
P/N. 90890-06754

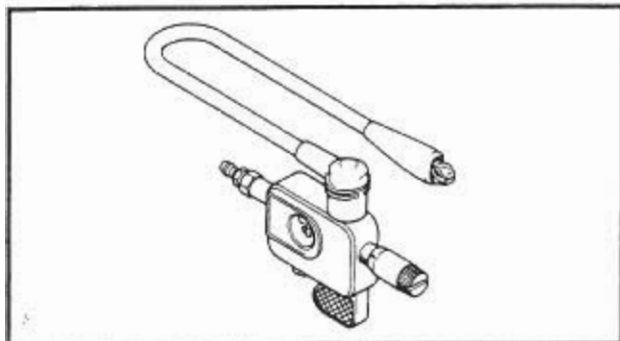

This instrument is necessary for checking the ignition system components.

2. Pocket tester
P/N. 90890-03112

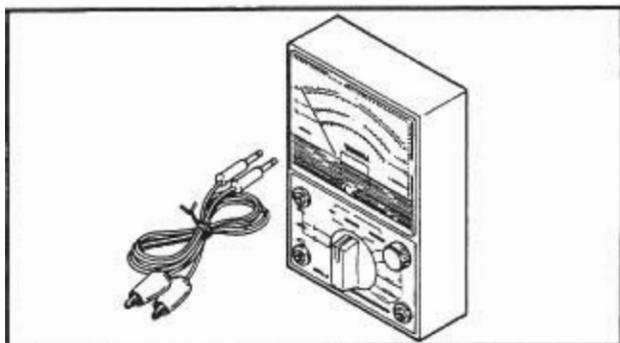

This tester is invaluable for checking the electrical system.



CHAPTER 2. SPECIFICATIONS

| | |
|---|------|
| GENERAL SPECIFICATIONS | A-15 |
| MAINTENANCE SPECIFICATIONS | A-16 |
| ENGINE | A-16 |
| CHASSIS | B-2 |
| ELECTRICAL | B-4 |
| GENERAL TORQUE SPECIFICATIONS | B-5 |
| LUBRICATION POINTS AND LUBRICANT TYPE | B-5 |
| ENGINE | B-5 |
| CHASSIS | B-6 |
| CABLE ROUTING | B-6 |



SPECIFICATIONS

GENERAL SPECIFICATIONS

| Model | DT175D |
|---|---|
| Model code number | 3FJ5 |
| Vehicle identification number (For AUS) | JYA1EJT0*NA028101 |
| Frame serial number (Except for AUS) | 1EJ-028101 |
| Engine starting number | 1EJ-028101 |
| Dimensions: | |
| Overall length | 2,110 mm (83.1 in) |
| Overall width | 865 mm (34.1 in) |
| Overall height | 1,165 mm (45.9 in) |
| Seat height | 830 mm (32.7 in) |
| Wheel base | 1,340 mm (52.8 in) |
| Minimum ground clearance | 260 mm (10.2 in) |
| Basic weight: | |
| With oil and full fuel tank | 107 kg (236 lb) |
| Minimum turning radius: | 2,100 mm (82.7 in) |
| Engine: | |
| Engine type | Air cooled 2-stroke, regular gasoline |
| Induction system | Reed valve |
| Cylinder arrangement | Single cylinder, forward inclined |
| Displacement | 171 cm ³ |
| Bore × stroke | 66.0 × 50.0 mm (2.60 × 1.97 in) |
| Compression ratio | 6.7 : 1 |
| Starting system | Kick starter |
| Lubrication system | Separate lubrication (Yamaha Autolube) |
| Engine oil: | |
| Type | Air-cooled 2-stroke engine oil |
| Capacity | 0.90 L (0.79 Imp qt, 0.95 US qt) |
| Transmission oil: | |
| Type | SAE 10W30 type SE motor oil |
| Capacity: | |
| Periodic oil change | 0.60 L (0.53 Imp qt, 0.63 US qt) |
| Total amount | 0.65 L (0.57 Imp qt, 0.69 US qt) |
| Air filter: | |
| Type | Wet element |
| Fuel: | |
| Type | For AUS: Unleaded fuel only Except for AUS: Regular gasoline |
| Fuel tank capacity: | |
| Full amount | 9.5 L (8.36 Imp gal, 10.04 US gal) |
| Reserve amount | 1.0 L (0.88 Imp gal, 1.06 US gal) |



| Model | DT175D | | |
|---|---|--|--|
| Carburetor: Type/Quantity Manufacturer | VM26SS/1 pc. MIKUNI | | |
| Spark plug: Type/Quantity Manufacturer Plug gap | B8ES/1 pc. NGK 0.7 ~ 0.8 mm (0.028 ~ 0.032 in) | | |
| Clutch: Type | Wet, multiple disc | | |
| Transmission: Type Primary reduction system Primary reduction ratio Secondary reduction system Secondary reduction ratio Operation Gear ratio: | Constant mesh 6-speed Helical gear 71/22 (3.227) Chain drive 49/16 (3.062) Left foot operation 1st 35/11 (3.181) 2nd 29/15 (1.933) 3rd 26/19 (1.368) 4th 24/22 (1.090) 5th 22/23 (0.956) 6th 21/25 (0.840) | | |
| Chassis: Frame type Caster angle Trail | Semi double cradle 29.66° 123 mm (4.84 in) | | |
| Tire: Type Size: Front Rear | With tube 2.75-21 4PR 4.10-18 4PR | | |
| Maximum load*: | 213 kg (470 lb) | | |
| Cold tire pressure: | | Front | Rear |
| | Up to 90 kg (198 lb) load* | 150 kPa (1.5 kg/cm ² , 21 psi) | 200 kPa (2.0 kg/cm ² , 29 psi) |
| | 90 kg (198 lb) ~ Maximum load* | 150 kPa (1.5 kg/cm ² , 21 psi) | 230 kPa (2.3 kg/cm ² , 33 psi) |
| | Off-road riding | 150 kPa (1.5 kg/cm ² , 21 psi) | 200 kPa (2.0 kg/cm ² , 28.5 psi) |

*Load is total weight of cargo, rider, passenger and accessories.

GENERAL SPECIFICATIONS

SPEC



A

| Model | DT175D |
|--|---|
| Brake: Front brake type Front brake operation Rear brake type Rear brake operation | Drum brake Right hand operation Drum brake Right foot operation |
| Suspension: Front suspension type Rear suspension type | Telescopic fork Swingarm (Monocross suspension) |
| Shock absorber: Front shock absorber Rear shock absorber | Coil spring/Oil damper Coil and gas spring/Oil damper |
| Wheel travel: Front wheel travel Rear wheel travel | 200 mm (7.8 in) 155 mm (6.1 in) |
| Electrical: Ignition system Generator system | CDI Flywheel magneto |
| Battery: Type Capacity | GM3-3B 12V 3AH |
| Headlight: Type | Bulb type |
| Bulb wattage (Quantity): Headlight Tail/Brake light Flasher light Auxiliary light Meter light "NEUTRAL" indicator light "HIGH BEAM" indicator light "OIL" indicator light "TURN" indicator light | 6V 35W/35W 6V 5.3W/25W 6V 17W (4 pcs.) 12V 4W (1 pc.) 12V 3.4W (2 pcs.) 12V 3W (1 pc.) 12V 3W (1 pc.) 12V 3W (1 pc.) 12V 3W (1 pc.) |



MAINTENANCE SPECIFICATIONS

ENGINE

| Model | | DT175D |
|--|---------------------------------|--|
| Cylinder head: Warpage limit | | 0.05 mm (0.002 in) *Lines indicate straightedge measurement. |
| Cylinder: Bore size Taper limit Out of round limit | | 66.00 ~ 66.02 mm (2.598 ~ 2.599 in) 0.05 mm (0.002 in) 0.01 mm (0.0004 in) |
| Piston: Piston size "D" Measuring point "a" | | 65.94 ~ 66.00 mm (2.596 ~ 2.598 in) 10 mm (0.4 in) |
| Piston off-set Piston-to-cylinder clearance < Limit > Over size: 1st 2nd | | 0 mm (0 in) 0.040 ~ 0.045 mm (0.0016 ~ 0.0018 in) < 0.1 mm (0.004 in) > 66.25 mm (2.61 in) 66.5 mm (2.62 in) |
| Piston ring: Sectional sketch | <p>Top ring</p> <p>2nd ring</p> | <p>Keystone type B = 1.2 mm (0.047 in) T = 2.4 mm (0.095 in)</p> <p>Plain type B = 1.2 mm (0.047 in) T = 2.4 mm (0.095 in)</p> |
| End gap (Installed) | Top ring 2nd ring | 0.30 ~ 0.50 mm (0.012 ~ 0.020 in) 0.30 ~ 0.50 mm (0.012 ~ 0.020 in) |
| Side clearance | Top ring 2nd ring | 0.030 ~ 0.050 mm (0.0012 ~ 0.0020 in) 0.030 ~ 0.050 mm (0.0012 ~ 0.0020 in) |

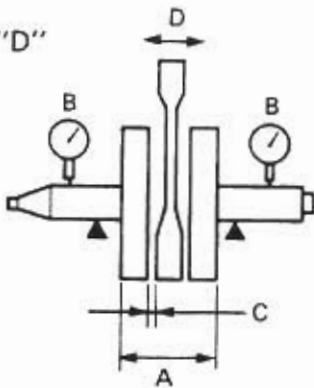

| Model | DT175D |
|--|---|
| <p>Crankshaft:</p> <p>Crank width "A"</p> <p>Runout limit "B"</p> <p>Big end side clearance "C"</p> <p>< Limit ></p> <p>Small end free play "D"</p>  | <p>55.90 ~ 55.95 mm (2.201 ~ 2.203 in)</p> <p>0.02 mm (0.0008 in)</p> <p>0.20 ~ 0.70 mm (0.008 ~ 0.028 in)</p> <p>< 1.0 mm (0.040 in) ></p> <p>0.8 ~ 1.2 mm (0.031 ~ 0.047 in)</p> |
| <p>Clutch:</p> <p>Friction plate:</p> <p>Thickness</p> <p>Quantity</p> <p>Wear limit</p> <p>Clutch plate:</p> <p>Thickness</p> <p>Quantity</p> <p>Warpage limit</p> <p>Clutch spring:</p> <p>Free length</p> <p>Quantity</p> <p>Minimum free length</p> <p>Clutch release method</p> <p>Push rod bending limit</p> | <p>2.9 ~ 3.1 mm (0.114 ~ 0.122 in)</p> <p>7 pcs.</p> <p>2.7 mm (0.106 in)</p> <p>1.2 mm (0.047 in)</p> <p>6 pcs.</p> <p>0.05 mm (0.002 in)</p> <p>34.5 mm (1.358 in)</p> <p>4 pcs.</p> <p>33.5 mm (1.319 in)</p> <p>Inner push, cam push</p> <p>0.5 mm (0.020 in)</p> |
| <p>Transmission:</p> <p>Main axle runout limit</p> <p>Drive axle runout limit</p> | <p>0.08 mm (0.003 in)</p> <p>0.08 mm (0.003 in)</p> |
| <p>Shifter:</p> <p>Type</p> | <p>Guide bar</p> |
| <p>Kick starter:</p> <p>Type</p> | <p>Kick and mesh type</p> |
| <p>Air filter:</p> <p>Oil grade</p> | <p>Foam-air-filter oil or air cooled 2 stroke engine oil</p> |

MAINTENANCE SPECIFICATIONS

SPEC



| Model | DT175D |
|--|--|
| Carburetor: I.D. mark Main jet (M.J.) Air jet (A.J.) Jet needle-position (J.N.) Needle jet (N.J.) Cutaway (C.A.) Pilot outlet (P.O.) Pilot jet (P.J.) Air screw (A.S.) Bypass 1 (B.P. 1) Valve seat size (V.S.) Starter jet (G.S.) Power jet (PW.J.) Fuel level (F.L.) Float height (F.H.) Idling speed | 18L00 #170 φ0.5 4L6-3 O-8 1.5 φ0.6 #20 1-1/2 φ1.4 φ2.5 #20 #40 0~1 mm (0~0.04 in) 20~22 mm (0.79~0.87 in) 1,300~1,400 r/min |
| Reed valve: Valve thickness Valve stopper height Valve bending limit | 0.2 mm (0.008 in) 4.7~5.1 mm (0.185~0.201 in) 0.5 mm (0.02 in) |
| Lubrication system: Autolube pump: Color code Minimum stroke Maximum stroke Minimum output Maximum output Pulley adjusting mark | Black 0.30~0.35 mm (0.012~0.014 in) 1.85~2.05 mm (0.073~0.081 in) 0.38~0.44 cm ³ 2.33~2.58 cm ³ At idle <input type="checkbox"/> |

MAINTENANCE SPECIFICATIONS

SPEC



| Tightening torque: | | | | | | | |
|----------------------------|---------------|------|-------------|-------------------|------|-------|---------|
| Parts to be tightened | Part name | Q'ty | Thread size | Tightening torque | | | Remarks |
| | | | | Nm | m•kg | ft•lb | |
| Spark plug | | 1 | M14×1.25 | 25 | 2.5 | 18 | |
| Cylinder head | Nut | 6 | M 8×1.25 | 25 | 2.5 | 18 | |
| Cylinder | Stud bolt | 4 | M10×1.25 | 15 | 1.5 | 11 | |
| | Nut | 4 | M10×1.25 | 35 | 3.5 | 25 | |
| Oil pump | Panhead screw | 2 | M 5×0.8 | 8 | 0.8 | 5.8 | |
| Reed valve | Panhead screw | 4 | M 3×0.5 | 1 | 0.1 | 0.7 | |
| Carburetor joint | Bolt | 4 | M 6×1.0 | 8 | 0.8 | 5.8 | |
| Exhaust pipe | | | | | | | |
| exhaust pipe | Nut | 2 | M 6×1.0 | 11 | 1.1 | 8 | |
| cylinder | Stud bolt | 2 | M 6×1.0 | 0.5 | 0.05 | 0.36 | |
| stay | Bolt | 1 | M 6×1.0 | 10 | 1 | 7.2 | |
| frame mount | Bolt | 1 | M 6×1.0 | 10 | 1 | 7.2 | |
| Transmission oil drain | Bolt | 1 | M12×1.5 | 20 | 2.0 | 14 | |
| Crankcase cover (left) | Screw | 6 | M 6×1.0 | 10 | 1.0 | 7.2 | |
| Crankcase cover (right) | Screw | 9 | M 6×1.0 | 10 | 1.0 | 7.2 | |
| Oil pump cover | Screw | 3 | M 6×1.0 | 8 | 0.8 | 5.8 | |
| Crankcase | Screw | 12 | M 6×1.0 | 8 | 0.8 | 5.8 | |
| Kick crank boss | Bolt | 1 | M 8×1.25 | 23 | 2.3 | 17 | |
| Oil seal retainer | Screw | 1 | M 8×1.25 | 10 | 1.0 | 7.2 | |
| Primary drive gear | Nut | 1 | M12×1.0 | 60 | 6.0 | 43 | |
| Clutch boss | Nut | 1 | M14×1.0 | 40 | 4.0 | 29 | |
| Clutch spring | Bolt | 4 | M 5×0.8 | 6 | 0.6 | 4.3 | |
| Clutch lever stopper | Bolt | 1 | M 8×1.25 | 10 | 1.0 | 7.2 | |
| Clutch free play adjusting | Nut | 1 | M 6×1.0 | 8 | 0.8 | 5.8 | |
| Plate bearing cover | Screw | 2 | M 6×1.0 | 10 | 1.0 | 7.2 | |
| Plate cover | Bolt | 2 | M 6×1.0 | 10 | 1.0 | 7.2 | |
| Drive sprocket | Nut | 1 | M16×1.0 | 55 | 5.5 | 40 | |
| Tachometer housing | Screw | 1 | M 6×1.0 | 8 | 0.8 | 5.8 | |
| Shifter stopper lever | Bolt | 1 | M 6×1.0 | 10 | 1.0 | 7.2 | |
| Shifter adjusting nut | Nut | 1 | M 8×1.25 | 30 | 3.0 | 22 | |
| Shift pedal | Bolt | 1 | M 6×1.0 | 11 | 1.1 | 8.0 | |
| Neutral switch | | 1 | M10×1.25 | 5 | 0.5 | 3.6 | |
| CDI (CDI magneto) | Nut | 1 | M12×1.25 | 70 | 7.0 | 50 | |
| Stator magneto | Screw | 2 | M 6×1.0 | 8 | 0.8 | 5.8 | |



CHASSIS

| Model | DT175D |
|--|--|
| Steering system: Bearing type Bearing size (Quantity): Upper Lower | Ball bearing 3/16 in (22 pcs.) 1/4 in (19 pcs.) |
| Front suspension: Front fork travel Fork spring free length < Limit > Spring rate (K ₁) Stroke (K ₁) Optional spring Oil capacity Oil level Oil grade | 200 mm (7.87 in) 428.5 mm (16.87 in) < 423 mm (16.65 in) > 6.0 N/mm (0.6 kg/mm, 4.3 lb/in) 0 ~ 200 mm (0 ~ 7.87 in) No. 254 cm ³ (8.94 Imp oz, 8.59 US oz) 467 mm (18.39 in) From top of inner tube fully extended without spring. Fork oil 10W or equivalent |
| Rear suspension: Shock absorber travel Spring free length < Limit > Fitting length Spring rate (K ₁) Stroke (K ₁) Optional spring Enclosed gas pressure | 84 mm (3.31 in) 258 mm (10.16 in) < 256 mm (10.08 in) > 230 mm (9.06 in) 36.5 N/mm (3.65 kg/mm, 25 lb/in) 0 ~ 84 mm (0 ~ 0.14 in) No. 1176.8 kPa (12 kg/cm ² , 171 psi) |
| Swingarm: Free play limit (swingarm end) | 1.0 mm (0.04 in) Move swingarm end side to side |
| Front wheel: Type Rim size Rim material Rim runout limit: Vertical Lateral | Spoke wheel 1.60 × 21 Steel 2.0 mm (0.08 in) 2.0 mm (0.08 in) |
| Rear wheel: Type Rim size Rim material Rim runout limit: Vertical Lateral | Spoke wheel 1.85 × 18 Steel 2.0 mm (0.08 in) 2.0 mm (0.08 in) |

| Tightening torque: | | | | | |
|---|-------------|-------------------|------|-------|-------------|
| Parts to be tightened | Thread size | Tightening torque | | | Remarks |
| | | Nm | m•kg | ft•lb | |
| Handle crown and inner tube | M10×1.25 | 34 | 3.4 | 24 | See "NOTE". |
| Handle crown and steering shaft (upper) | M14×1.25 | 54 | 5.4 | 39 | |
| Handle crown and steering shaft (side) | M 8×1.25 | 23 | 2.3 | 17 | |
| Handlebar holder | M 8×1.25 | 15 | 1.5 | 11 | |
| Steering shaft and locknut | M25×1.0 | 6 | 0.6 | 4.3 | |
| Handle crown pinch bolt | M 8×1.25 | 23 | 2.3 | 17 | |
| Engine stay (front) and frame | M 8×1.25 | 32 | 3.2 | 23 | |
| Engine and frame (rear upper) | M 8×1.25 | 32 | 3.2 | 23 | |
| Engine and frame (rear lower) | M10×1.25 | 39 | 3.9 | 28 | |
| Pivot shaft and frame | M12×1.25 | 53 | 5.3 | 38 | |
| Rear shock absorber and frame | M10×1.25 | 32 | 3.2 | 23 | |
| Chain guide | M 6×1.0 | 7 | 0.7 | 5.1 | |
| Chain cover | M 6×1.0 | 4 | 0.4 | 2.9 | |
| Fuel tank | M 6×1.0 | 5 | 0.5 | 3.6 | |
| Seat bracket | M 8×1.25 | 15 | 1.5 | 11 | |
| Front wheel axle | M10×1.25 | 39 | 3.9 | 28 | |
| Rear wheel axle and nut | M14×1.5 | 85 | 8.5 | 61 | |
| Camshaft lever bolt | M 6×1.0 | 8 | 0.8 | 5.8 | |
| Wheel sprocket and hub | M10×1.25 | 39 | 3.9 | 25 | |
| Sidestand | M10×1.25 | 40 | 4.0 | 29 | |
| Sidestand switch | M 5×0.8 | 4 | 0.4 | 2.9 | |
| Cap bolt | M30×1.0 | 23 | 2.3 | 17 | |
| Damper rod (bolt) | M10×1.0 | 23 | 2.3 | 17 | |

NOTE:

1. First, tighten the ring nut approximately 38 Nm (3.8 m•kg, 27 ft•lb) by using the torque wrench, then loosen the ring nut one turn.
2. Retighten the ring nut to specification.



ELECTRICAL

| Model | DT175D |
|---|---|
| Voltage: | 12V |
| Ignition system: Ignition timing (B.T.D.C.) Advancer type | 18° at 3,000 r/min Electrical type |
| CDI: Magneto model/Manufacturer CDI unit model/Manufacturer Pickup coil resistance (color) Source coil resistance (color) | F4T202/YAMAHA 3BN/YAMAHA 8 ~ 12Ω at 20°C (68°F) (White/Red—White/Green) 270 ~ 330Ω at 20°C (68°F) (Black/Red—Black) |
| Ignition coil: Model/Manufacturer Minimum spark gap Primary coil resistance Secondary coil Resistance | F06T41174/MITSUBISHI 6 mm (0.24 in) 0.8 ~ 1.2Ω at 20°C (68°F) 4.72 ~ 7.08kΩ at 20°C (68°F) |
| Spark plug cap: Type Plug cap resistance | Rubber type 5.46 ~ 7.34kΩ at 20°C (68°F) |

MAINTENANCE SPECIFICATIONS

SPEC



| Model | DT175D | | | | | | | | | | | | | | | | | | | | | | | | | | | |
|--|---|------------------------------|------------------------|--------------------------|---|-----|-----|---|-----|-----|---|-----|-----|---|-----|-----|---|-----|-----|---|-----|-----|---|-----|-----|---|-----|-----|
| Charging system: | Flywheel magneto | | | | | | | | | | | | | | | | | | | | | | | | | | | |
| Flywheel magneto: Model/Manufacturer Charging coil resistance (color) Lighting coil resistance Standard output | F4T202/YAMAHA 0.24 ~ 0.36Ω at 20°C (68°F) (White/Green—Black) 0.14 ~ 0.22Ω at 20°C (68°F) (Yellow—Black) 12V 1.1A at 2,500 r/min When "LIGHT" switch is turned to "OFF". | | | | | | | | | | | | | | | | | | | | | | | | | | | |
| <table border="1" style="margin: 10px auto; border-collapse: collapse;"> <caption>Approximate data from the Output Current graph</caption> <thead> <tr> <th>Engine Speed (x 1,000 r/min)</th> <th>Day Output Current (A)</th> <th>Night Output Current (A)</th> </tr> </thead> <tbody> <tr><td>1</td><td>0.5</td><td>0.5</td></tr> <tr><td>2</td><td>1.5</td><td>1.2</td></tr> <tr><td>3</td><td>2.5</td><td>1.8</td></tr> <tr><td>4</td><td>3.2</td><td>2.1</td></tr> <tr><td>5</td><td>3.8</td><td>2.3</td></tr> <tr><td>6</td><td>4.2</td><td>2.4</td></tr> <tr><td>7</td><td>4.4</td><td>2.4</td></tr> <tr><td>8</td><td>4.5</td><td>2.5</td></tr> </tbody> </table> | | Engine Speed (x 1,000 r/min) | Day Output Current (A) | Night Output Current (A) | 1 | 0.5 | 0.5 | 2 | 1.5 | 1.2 | 3 | 2.5 | 1.8 | 4 | 3.2 | 2.1 | 5 | 3.8 | 2.3 | 6 | 4.2 | 2.4 | 7 | 4.4 | 2.4 | 8 | 4.5 | 2.5 |
| Engine Speed (x 1,000 r/min) | Day Output Current (A) | Night Output Current (A) | | | | | | | | | | | | | | | | | | | | | | | | | | |
| 1 | 0.5 | 0.5 | | | | | | | | | | | | | | | | | | | | | | | | | | |
| 2 | 1.5 | 1.2 | | | | | | | | | | | | | | | | | | | | | | | | | | |
| 3 | 2.5 | 1.8 | | | | | | | | | | | | | | | | | | | | | | | | | | |
| 4 | 3.2 | 2.1 | | | | | | | | | | | | | | | | | | | | | | | | | | |
| 5 | 3.8 | 2.3 | | | | | | | | | | | | | | | | | | | | | | | | | | |
| 6 | 4.2 | 2.4 | | | | | | | | | | | | | | | | | | | | | | | | | | |
| 7 | 4.4 | 2.4 | | | | | | | | | | | | | | | | | | | | | | | | | | |
| 8 | 4.5 | 2.5 | | | | | | | | | | | | | | | | | | | | | | | | | | |
| Voltage regulator: Type | Semi conductor—short circuit type | | | | | | | | | | | | | | | | | | | | | | | | | | | |
| Rectifier: Model/Manufacturer Capacity | EHU-01TR27/MATSUSHITA 8A | | | | | | | | | | | | | | | | | | | | | | | | | | | |
| Battery: Specific gravity | 1.280 | | | | | | | | | | | | | | | | | | | | | | | | | | | |
| Horn: Type Quantity Model/Manufacturer Maximum Amperage | Plane type 1 pc. MF-12/NIKKO 1.5A | | | | | | | | | | | | | | | | | | | | | | | | | | | |



| Model | DT175D |
|--|--|
| Flasher relay: Type Model/Manufacturer Self cancelling device Flasher frequency Wattage | Condenser type FZ249SD/NIPPONDENSO No 75 ~ 95 cycle/min 21W × 2 + 3.4W |
| Ignition control unit: Model/Manufacturer | F6T/YAMAHA |
| Oil level switch: Model/Manufacturer | 3J0/STANLEY |
| Circuit breaker: Type | Fuse |
| Circuit (fuse): "MAIN" | 10A (1 pc.) |

GENERAL TORQUE SPECIFICATIONS

This chart specifies torque for standard fasteners with standard I.S.O. pitch threads. Torque specifications for special components or assemblies are included in the applicable sections of this book. To avoid warpage, tighten multi-fastener assemblies in a crisscross fashion, in progressive stages, until full torque is reached. Unless otherwise specified, torque specifications call for clean, dry threads. Components should be at room temperature.

| A (Nut) | B (Bolt) | General torque specifications | | |
|------------|-------------|-------------------------------|------|-------|
| | | Nm | m•kg | ft•lb |
| 10 mm | 6 mm | 6 | 0.6 | 4.3 |
| 12 mm | 8 mm | 15 | 1.5 | 11 |
| 14 mm | 10 mm | 30 | 3.0 | 22 |
| 17 mm | 12 mm | 55 | 5.5 | 40 |
| 19 mm | 14 mm | 85 | 8.5 | 61 |
| 22 mm | 16 mm | 130 | 13.0 | 94 |

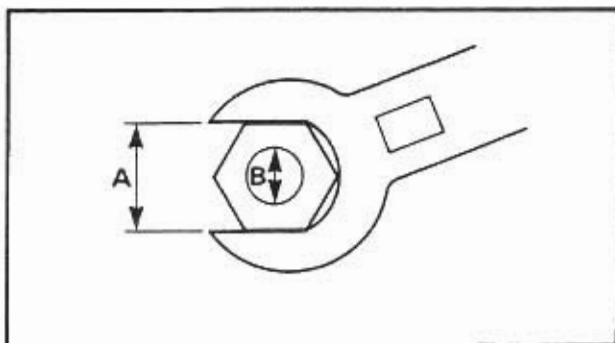

A: Distance across flats
B: Outside thread diameter

LUBRICATION POINTS AND LUBRICANT TYPE

SPEC



LUBRICATION POINTS AND LUBRICANT TYPE

ENGINE

| Lubrication Points (Part name) | Lubricant Type |
|--|-----------------------|
| Oil seal lips (all) | |
| O-rings (all) | |
| Bearing retainer Crankshaft bearings (left and center) Needle bearings (connecting rod) Main axle bearings Drive axle bearings Push lever bearing | |
| Crank pins | |
| Piston rings, piston pins and pistons | |
| Warm shaft (Autolube pump) | |
| Kick idle gear | |
| Kick axle | |
| Primary driven gear (clutch housing) | |
| Push rod | |
| Push lever axle | |
| Sliding gear (transmission) | |
| Free movement gear (transmission) | |
| Guide bar (shift forks) | |
| Crankcase mating surfaces | Yamaha bond No. 1215® |

LUBRICATION POINTS AND LUBRICANT TYPE

SPEC



CHASSIS

| Lubrication Points (Part name) | Lubricant Type |
|---|----------------|
| Ball bearing (steering shaft) | |
| Oil seal (front wheel) | |
| Gear (speedometer) | |
| Camshaft (front and rear brake) | |
| Oil seal (rear wheel) | |
| Arm head pipe (rear arm) | |
| Inner collar (rear arm) | |
| Outer collar (rear arm) | |
| Shaft (rear brake pedal) | |
| Throttle grip inner surface | |
| Lever pivots and cable end (clutch brake) | |
| Boss (tensioner arm) | |
| Sidestand pivot | |
| Frame head pipe | |

CABLE ROUTING

- ① Front brake cable
- ② Front brake switch lead
- ③ Throttle cable
- ④ "ENGINE STOP" switch lead
- ⑤ Band
- ⑥ Handlebar switch (left) lead
- ⑦ Clutch cable
- ⑧ Cable guide
- ⑨ Speedometer cable

- ⑩ Front flasher light lead
- ⑪ Headlight lead
- ⑫ Tachometer cable
- ⑬ Horn lead
- ⑭ Main switch lead
- ⑮ Tachometer lead
- ⑯ Speedometer lead
- ⑰ Cable guide

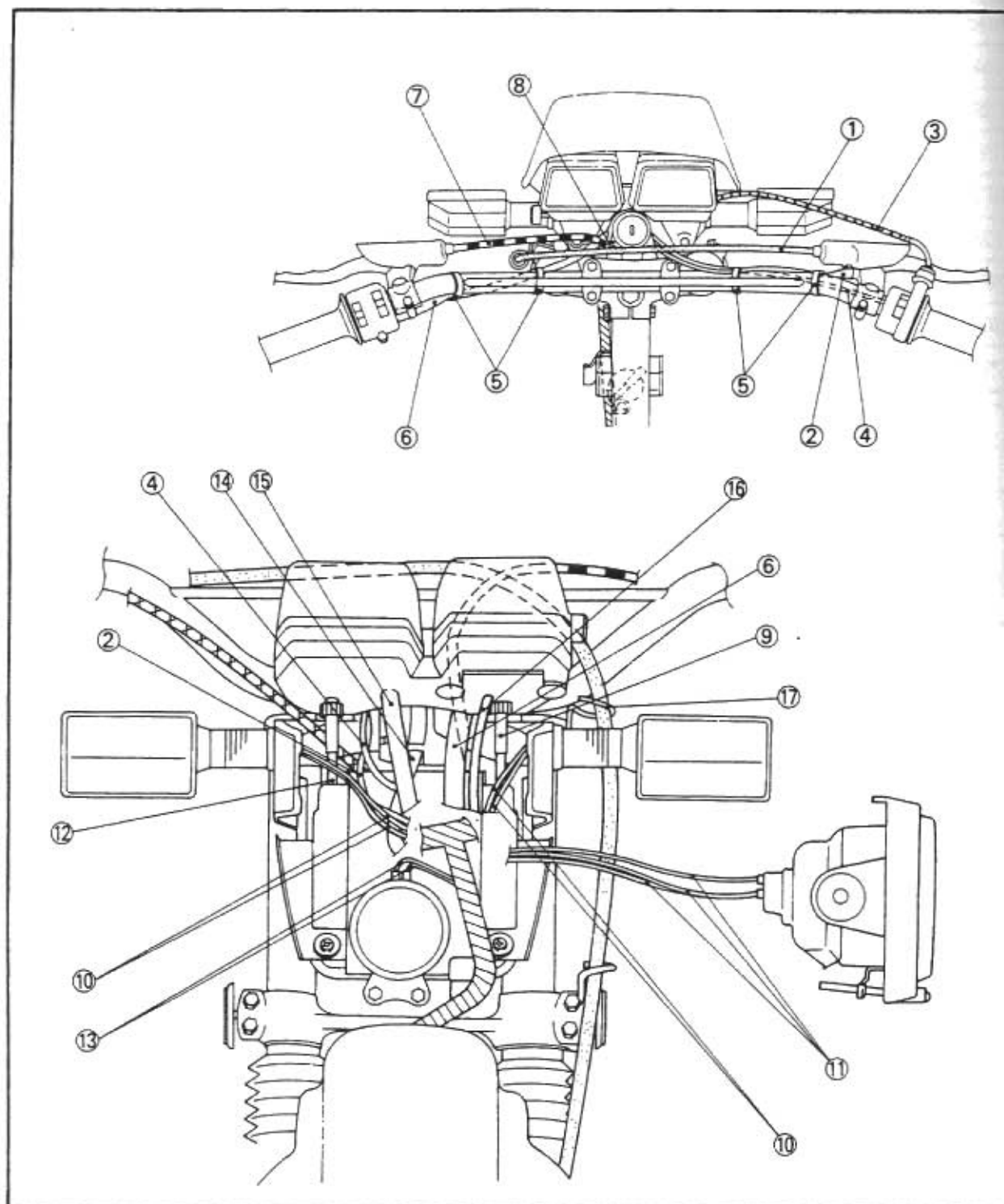

CABLE ROUTING

SPEC



- ① Tachometer cable
- ② Clamp
- ③ Band
- ④ High tension cord
- ⑤ Throttle cable (pump)
- ⑥ Delivery hose
- ⑦ Oil hose
- ⑧ Crankcase breather hose
- ⑨ Air vent hose
- ⑩ Carburetor breather hose

- ⑪ Battery lead
- ⑫ Fuse holder
- ⑬ CDI lead
- ⑭ Band
- ⑮ Oil level gauge lead
- ⑯ Oil tank bracket
- ⑰ Throttle cable (carburetor)
- ⑱ Oil tank breather hose
- ⑲ Flasher relay lead
- ⑳ Band

- ㉑ Ignition coil first lead 1
- ㉒ Ignition coil earth
- ㉓ Band
- ㉔ Clamp
- ㉕ Flywheel magneto lead
- ㉖ Clamp
- ㉗ Regulator lead
- ㉘ Rear brake switch lead
- ㉙ Battery breather hose

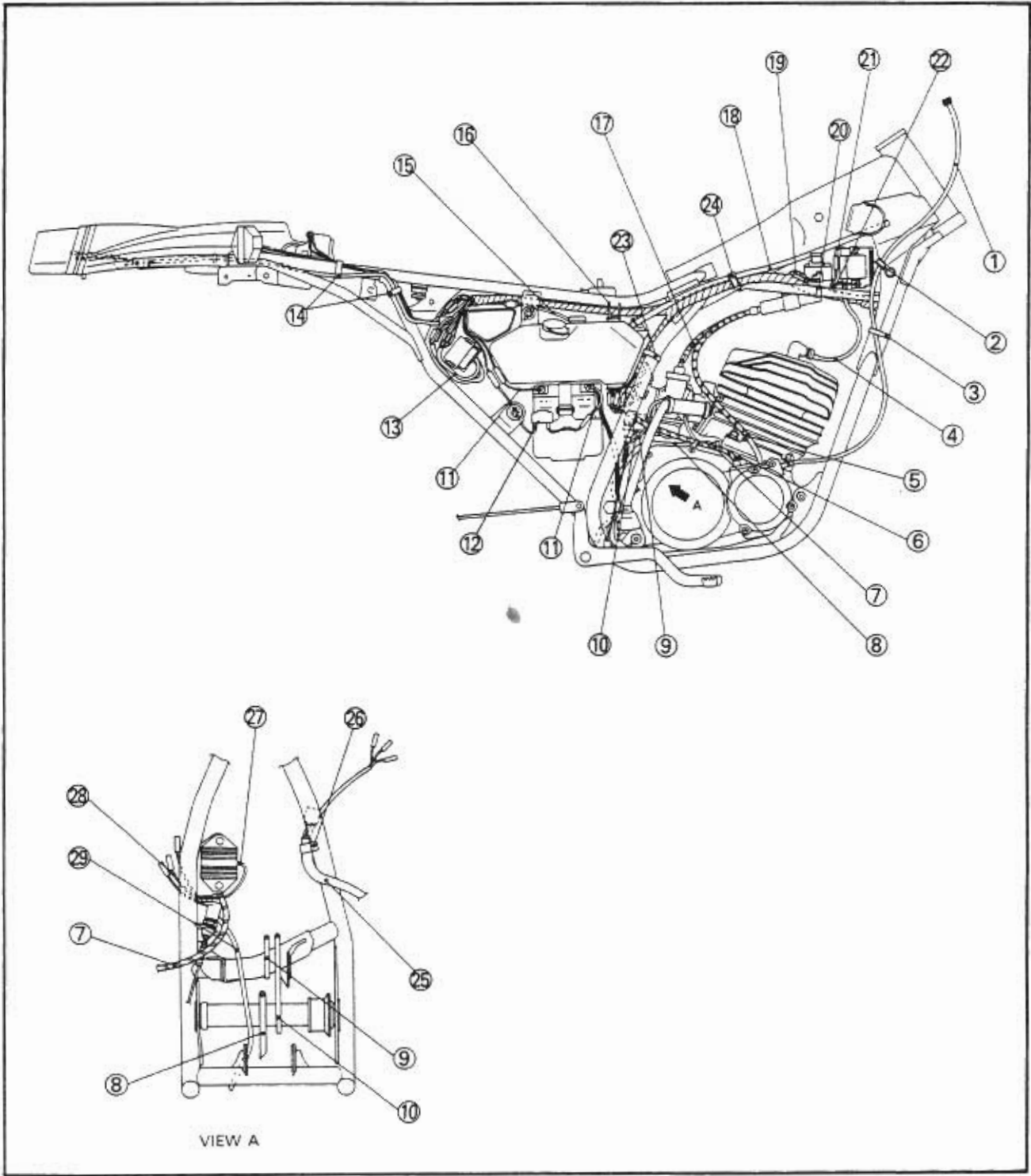

- ① Flywheel magneto lead
- ② Neutral switch lead
- ③ Clamp
- ④ Clutch cable
- ⑤ Speedometer cable
- ⑥ Cable holder
- ⑦ Clamp

- ⑧ Front brake cable
- ⑨ Cable holder
- ⑩ Cable guide
- ⑪ Throttle cable
- ⑫ Wireharness
- ⑬ Rectifier lead
- ⑭ Clamp

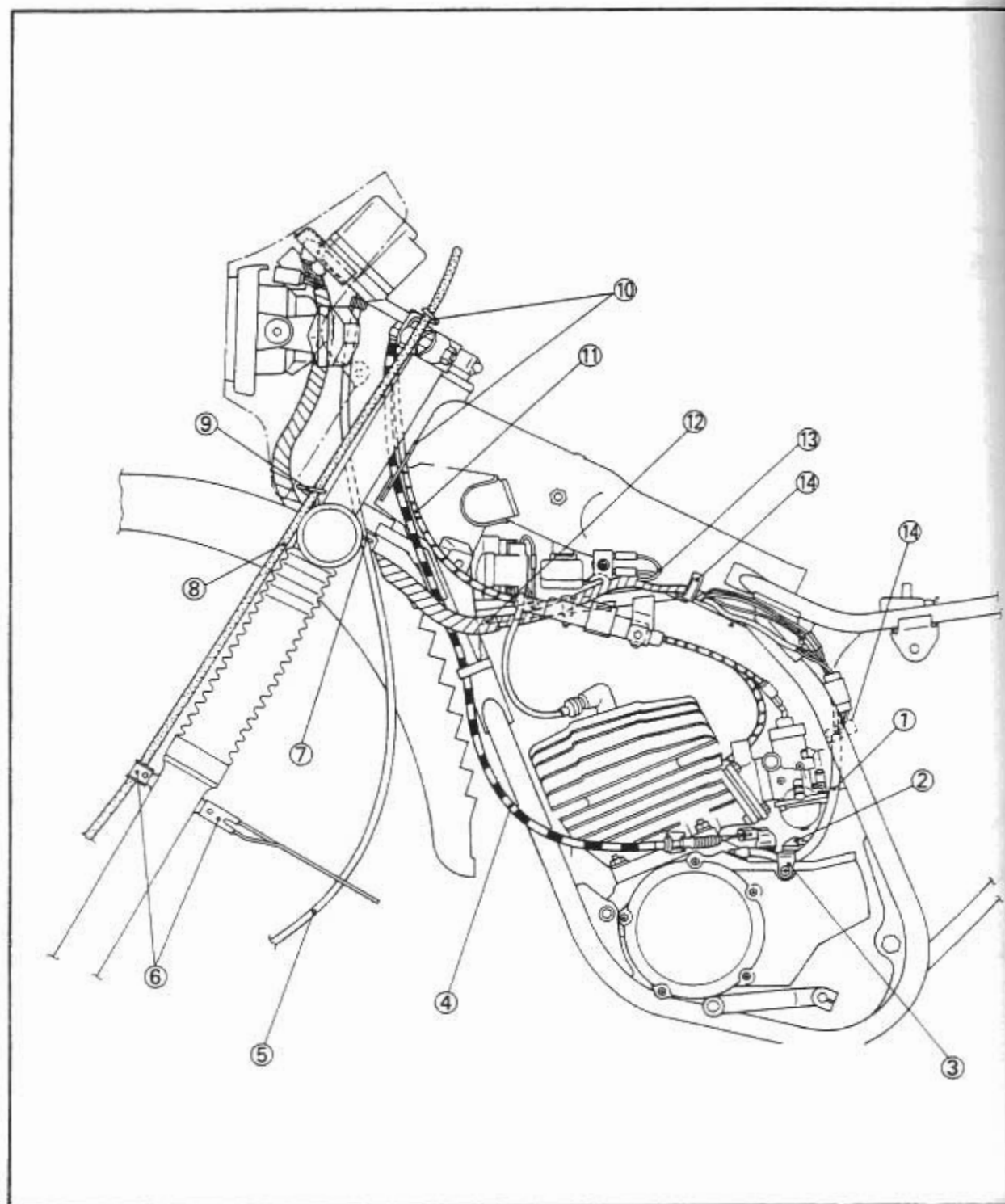



- ① Oil level gauge lead
- ② Taillight lead
- ③ Rear flasher light (right) lead
- ④ Lead holder
- ⑤ Clamp
- ⑥ Rear flasher light (left) lead
- ⑦ Clamp

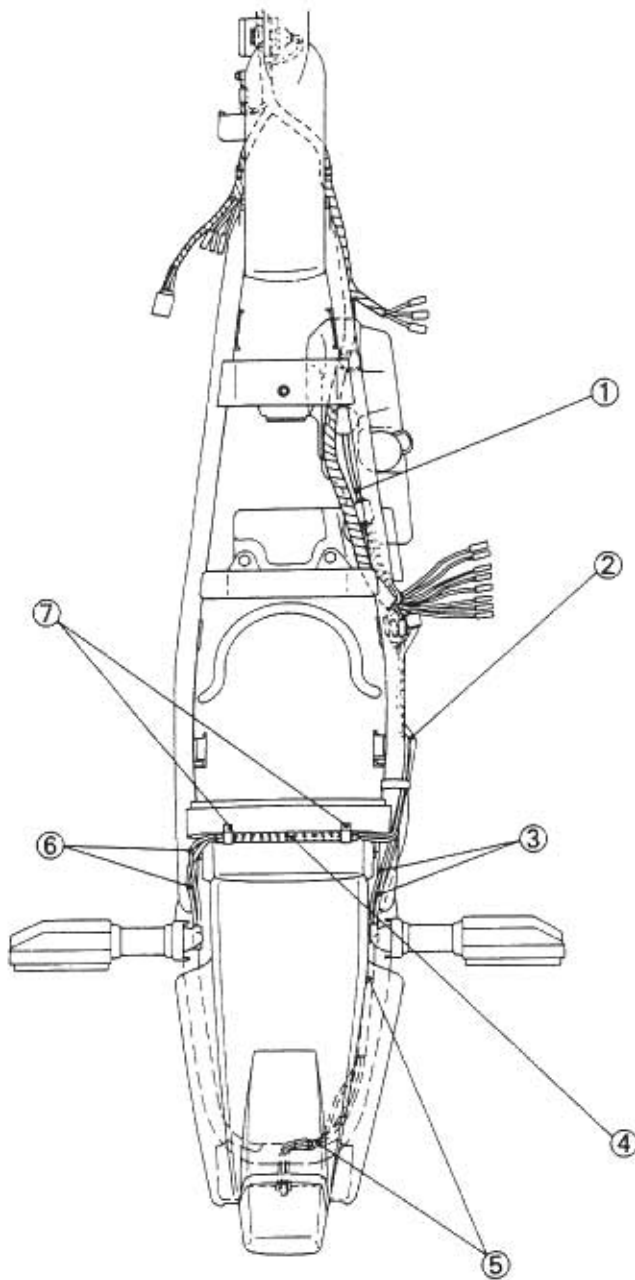



CHAPTER 3. PERIODIC INSPECTION AND ADJUSTMENT

| | |
|---|------|
| INTRODUCTION | B-12 |
| PERIODIC MAINTENANCE/LUBRICATION | B-12 |
| ENGINE | B-12 |
| IDLE SPEED ADJUSTMENT | B-12 |
| THROTTLE CABLE ADJUSTMENT | B-13 |
| AUTOLUBE PUMP STROKE ADJUSTMENT | B-13 |
| AUTOLUBE PUMP AIR BLEEDING | B-14 |
| SPARK PLUG INSPECTION | B-15 |
| IGNITION TIMING CHECK | B-15 |
| ENGINE OIL LEVEL INSPECTION | B-16 |
| TRANSMISSION OIL LEVEL INSPECTION | B-16 |
| TRANSMISSION OIL REPLACEMENT | C-1 |
| CLUTCH ADJUSTMENT | C-2 |
| AIR FILTER CLEANING | C-3 |
| CHASSIS | C-4 |
| FRONT BRAKE ADJUSTMENT | C-4 |
| REAR BRAKE ADJUSTMENT | C-4 |
| DRIVE CHAIN SLACK ADJUSTMENT | C-5 |
| DRIVE CHAIN LUBRICATION | C-6 |
| STEERING HEAD ADJUSTMENT | C-6 |
| FRONT FORK INSPECTION | C-7 |
| REAR SHOCK ABSORBER ADJUSTMENT | C-7 |
| TIRE INSPECTION | C-7 |
| WHEEL INSPECTION | C-9 |
| SPOKES INSPECTION AND TIGHTENING | C-9 |
| ELECTRICAL | C-10 |
| BATTERY INSPECTION | C-10 |
| FUSE INSPECTION | C-11 |
| HEADLIGHT BEAM ADJUSTMENT | C-12 |
| HEADLIGHT BULB REPLACEMENT | C-12 |



PERIODIC INSPECTION AND ADJUSTMENT

INTRODUCTION

This chapter includes all information necessary to perform recommended inspections and adjustments. These preventive maintenance procedures, if followed, will ensure more reliable vehicle operation and a longer service life. The need for costly overhaul work will be greatly reduced. This information applies to vehicles already in service as well as new vehicles that are being prepared for sale. All serviced technicians should be familiar with this entire chapter.

PERIODIC MAINTENANCE/LUBRICATION

Unit: km (miles)

| ITEM | REMARKS | BREAK-IN 1,000 (600) | EVERY | |
|----------------------|---|-------------------------|---------------------------------|-----------------------------------|
| | | | 6,000 (4,000) or 6 months | 12,000 (8,000) or 12 months |
| Spark plug | Check condition. Clean or replace if necessary. | ○ | ○ | ○ |
| Air filter | Clean. Replace if necessary. | | ○ | ○ |
| Carburetor* | Check idle speed/starter operation. Adjust if necessary. | ○ | ○ | ○ |
| Fuel line* | Check fuel hose and vacuum pipe for cracks or damage. Replace if necessary. | | ○ | ○ |
| Transmission oil* | Check oil level/oil leakage. Correct if necessary. Replace every 24,000 (16,000) or 24 months. (Warm engine before draining). | REPLACE | ○ | ○ |
| Autolube pump* | Check operation. Correct if necessary. Air bleeding. | ○ | ○ | ○ |
| Brake | Check operation. Adjust if necessary. | | ○ | ○ |
| Clutch | Check operation. Adjust if necessary. | | ○ | ○ |
| Rear arm pivot* | Check rear arm assembly for looseness. Correct if necessary. Moderately repack every 24,000 (16,000) or 24 months.** | | | ○ |
| Wheels* | Check balance/damage/runout/spoke tightness. Repair if necessary. | | ○ | ○ |
| Wheel bearings* | Check bearings assembly for looseness/damage. Replace if damaged. | | ○ | ○ |
| Steering bearing* | Check bearings assembly for looseness. Correct if necessary. Moderately repack every 24,000 (16,000) or 24 months.** | ○ | | ○ |
| Front forks* | Check operation/oil leakage. Repair if necessary. | | ○ | ○ |
| Rear shock absorber* | Check operation/oil leakage. Repair if necessary. | | ○ | ○ |
| Drive chain | Check chain slack/alignment. Adjust if necessary. Clean and lube. | | EVERY 500 (300) | |
| Fittings/Fasteners* | Check all chassis fittings and fasteners. Correct if necessary. | ○ | ○ | ○ |
| Sidestand* | Check operation. Repair if necessary. | ○ | ○ | ○ |
| Sidestand switch* | Check operation. Clean or replace if necessary. | ○ | ○ | ○ |
| Battery* | Check specific gravity. Check breather pipe for proper operation. Correct if necessary. | | ○ | ○ |

*: It is recommended that these items be serviced by a Yamaha dealer.

** : Medium weight wheel bearing grease.

***: Lithium soap base grease.



ENGINE

EB1AE004

IDLING SPEED ADJUSTMENT

1. Start the engine and let it warm up for several minutes.
2. Attach:
 - Inductive tachometer (to the spark plug lead)

| | |
|--|--|
| | Inductive tachometer: P/N. 90890-03113 |
|--|--|

3. Check:
 - Engine idling speed
 - Out of specification → Adjust.

| | |
|--|--|
| | Engine idling speed: 1,300 ~ 1,400 r/min |
|--|--|

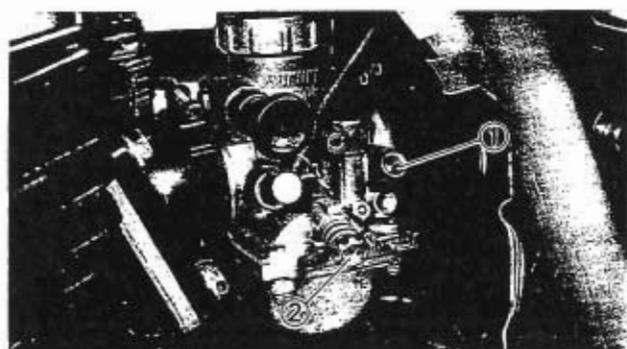

4. Adjust:
 - Engine idling speed

Adjustment steps:

- Turn in the pilot air screw ① until it is lightly seated.
- Turn out the pilot air screw for the specified number of turns.

| |
|--|
| Pilot air screw: 1-1/2 turns out |
|--|

- Turn the throttle stop screw ② in or out until specified idling speed is obtained.

| |
|--|
| Turning in → Idling speed higher. |
| Turning out → Idling speed lower. |

5. Adjust:
 - Throttle cable free play ③
 - Refer to "THROTTLE CABLE FREE PLAY ADJUSTMENT" section.

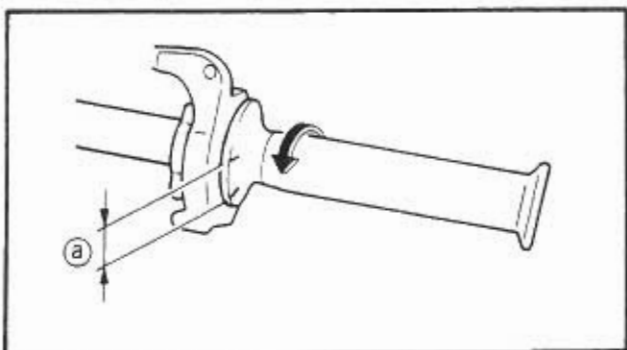

| | |
|--|--|
| | Free play: 2 - 5 mm (0.08 - 0.20 in) |
|--|--|



THROTTLE CABLE ADJUSTMENT

NOTE:

Engine idling speed should be adjusted properly before adjusting the throttle cable free play.

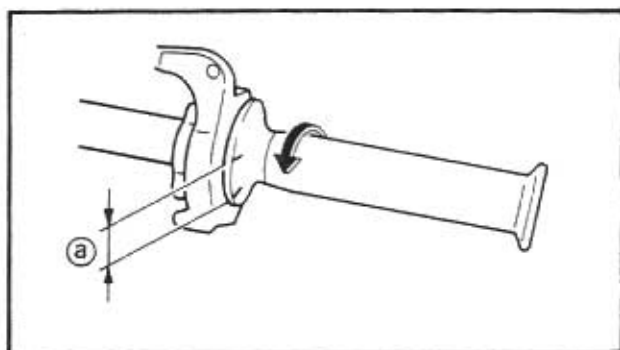

1. Check:

- Throttle cable free play (a)
Out of specification → Adjust.



Free play:
2~5 mm (0.08~0.20 in)
At throttle grip end

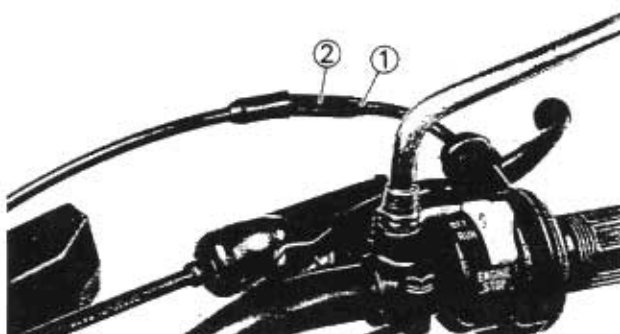

2. Adjust:

- Throttle cable free play

Adjustment steps:

- Loosen the locknut (1).
- Turn the adjuster (2) in or out until the specified free play is obtained.

Turning in → Free play is increased.

Turning out → Free play is decreased.

- Tighten the locknut.

3. Pull back the adjuster cover (1).

4. Check:

- Throttle cable free play (a)
Out of specification → Adjust.

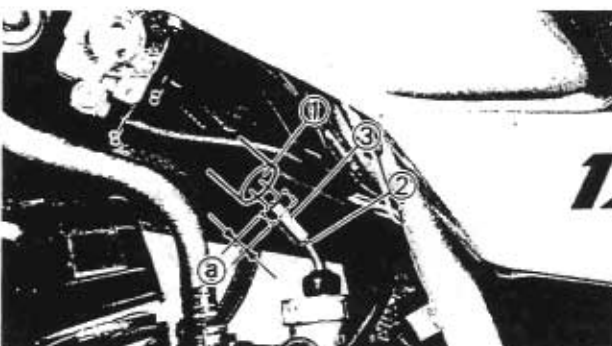

Throttle cable free play:
1.0 mm (0.04 in)
At carburetor side

5. Adjust:

- Throttle cable free play

Adjustment steps:

- Loosen the locknut ②.
- Turn the adjuster ③ in or out until the correct free play is obtained.

| | |
|----------|-------------------------|
| Turn in | Free play is increased. |
| Turn out | Free play is decreased. |

- Tighten the locknut.

6. Push in the adjuster cover.

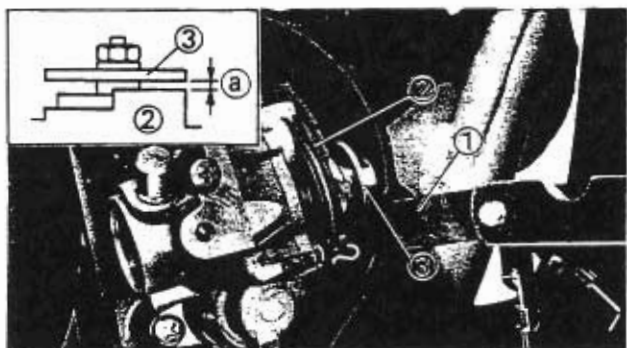
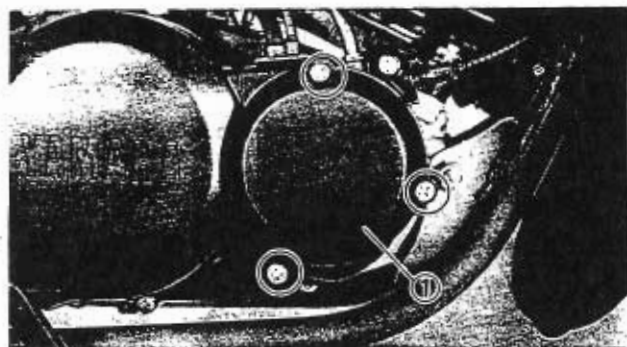

AUTOLUBE PUMP STROKE ADJUSTMENT

1. Remove:

- Autolube pump cover ①

2. While running the engine at idle, observe the pump adjusting plate carefully. Stop the engine the moment that the adjusting plate ③ moves out to its limit.

3. Measure:

- Gap
Out of specification → Adjust.
With the adjusting plate in the innermost position, use a thickness gauge ① to measure the gap between the raised boss ② on the pump adjusting pulley and the adjusting plate ③.

| | |
|--|-----------------------------------|
| | Minimum pump stroke: |
| | 0.30 ~ 0.35 mm (0.012 ~ 0.014 in) |

NOTE:

When inserting the thickness gauge between the adjusting plate and the adjusting pulley, be careful that neither the plate nor the pulley is moved.

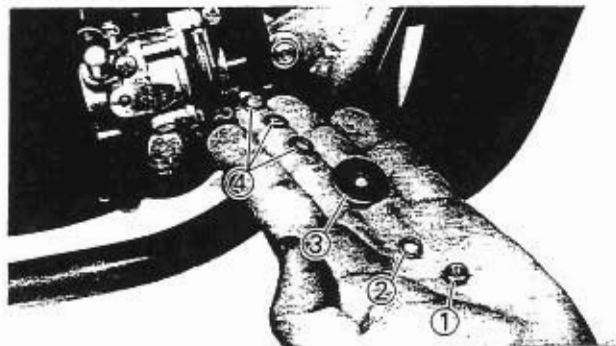

4. Adjust:
- Autolube pump minimum stroke

Adjustment steps:

- Remove the locknut ①, spring washer ② and adjusting plate ③.
- Adjust the pump stroke by adding or removing a shim ④.

| |
|---|
| Adding shim → Pump stroke is increased. |
| Removing shim → Pump stroke is decreased. |

- Install the adjusting plate, spring washer and locknut.



| |
|---|
| Locknut: 7 Nm (0.7 m•kg, 5.1 ft•lb) |
|---|

- Recheck the minimum pump stroke. If out of specification, perform the previous steps again.

5. Install:
- Autolube pump cover



| |
|---|
| Screw (Autolube pump cover): 8 Nm (0.8 m•kg, 5.8 ft•lb) |
|---|

AUTOLUBE PUMP AIR BLEEDING

CAUTION:

The Autolube pump and delivery lines must be bled on the following occasions:

- Setting up a new motorcycle out of the crate.
- Whenever the oil tank has run dry.
- Whenever any portion of the engine oil system is disconnected.

1. Remove:
- Side cover (right) ①



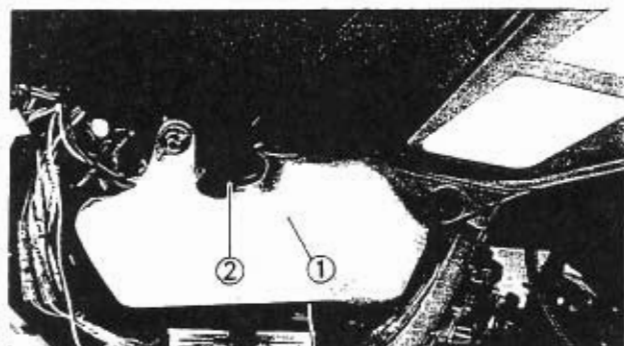

2. Remove:
 - Autolube pump cover
3. Fill:
 - Oil tank ①

| | |
|---|---------------------------------------|
|  | Air-cooled 2-stroke engine oil |
|---|---------------------------------------|

② Oil tank filler cap

4. Inspect:
 - Engine oil level
Oil level low → Add oil to proper level.
Refer to the "ENGINE OIL LEVEL INSPECTION" section.

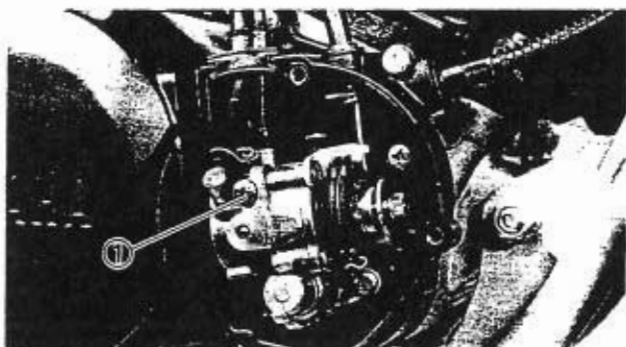

5. Air bleed:
 - Pump case and/or oil hose

Air bleeding steps:

- Place a rag under the Autolube pump to catch the oil.
- Remove the bleed screw ①.
- Keep the oil running out until air bubbles disappear.
- When air bubbles are expelled completely, tighten the bleed screw.

NOTE: _____
Check the bleed screw gasket. If damaged, replace with a new one.

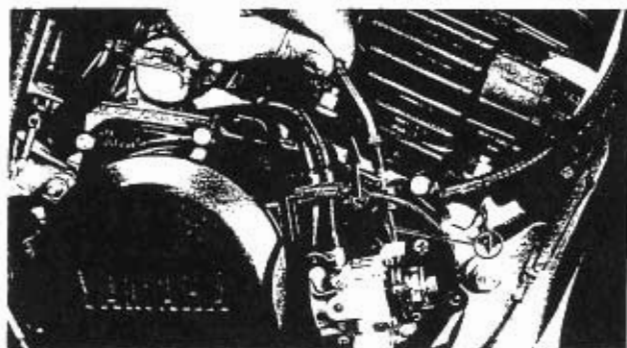

6. Air bleed:
 - Pump distributor and/or delivery hose

Air bleeding steps:

- Start the engine.
- Pull the pump cable ① all the way out to set the pump stroke to a maximum.



NOTE:

It is difficult to bleed the distributor completely with the pump stroke at a minimum. Therefore, the pump stroke should be set to a maximum.

- Run the engine for 2–3 minutes at 2,000 r/min. This will completely remove Autolube pump system of air.

7. Install:

- Autolube pump cover



Screw (Autolube pump cover):
8 Nm (0.8 m•kg, 5.8 ft•lb)

- Side cover (right)

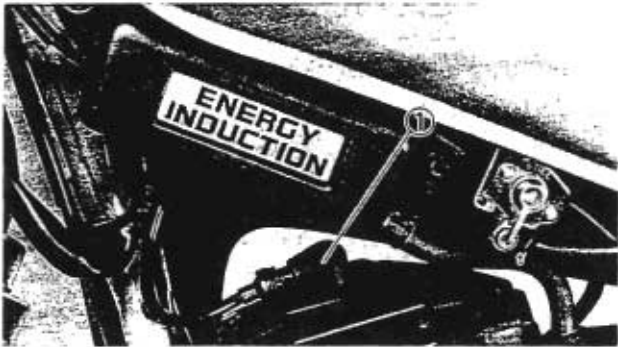

SPARK PLUG INSPECTION

1. Remove:

- Spark plug cap ①

2. Remove:

- Spark plug

3. Inspect:

- Spark plug type
Incorrect → Replace.

Standard spark plug:
B8ES (NGK)

4. Inspect:

- Electrode ①
Wear/Damage → Replace.
- Insulator ②
Abnormal color → Replace.
Normal color is a medium-to-light tan color.

5. Clean the spark plug with a spark plug cleaner or wire brush.

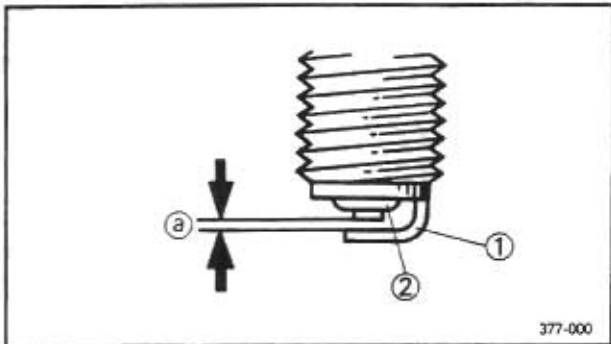

377-000

6. Measure:

- Plug gap (a)

Use a Wire Gauge or Feeler Gauge.
Out of specification → Re-gap.



Spark plug gap:
0.7 – 0.8 mm (0.028 – 0.032 in)

7. Tighten:

- Spark plug



Spark plug:
25 Nm (2.5 m•kg, 18 ft•lb)

NOTE: _____

Before installing a spark plug, clean the gasket surface and plug surface.

8. Install:

- Spark plug cap

IGNITION TIMING CHECK

NOTE: _____

Engine idling speed and throttle cable free play should be adjusted properly before checking the ignition timing.

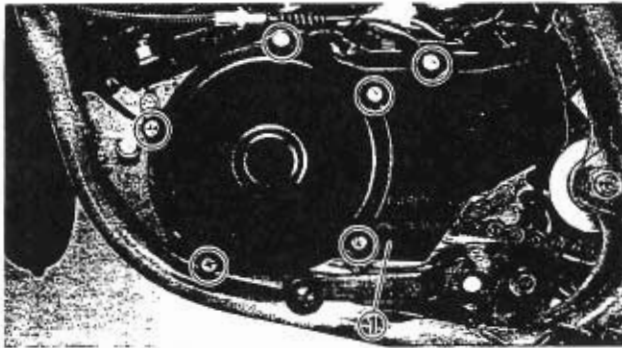

1. Remove:

- Crankcase cover (left) (1)

2. Attach:

- Timing light and inductive tachometer
(To the spark plug lead for #1 cylinder)



Timing light:
P/N. 90890-03141
Inductive tachometer:
P/N. 90890-03113

3. Check:
 - Ignition timing

Checking steps:

- Warm up the engine and keep it at the specified speed.

| | |
|---|--------------------------------------|
|  | Engine speed: 3,000 r/min. |
|---|--------------------------------------|

- Visually check the stationary pointer ① to verify it is within the required firing range ② indicated on the flywheel.
 Incorrect firing range → Check flywheel and/or pickup assembly.

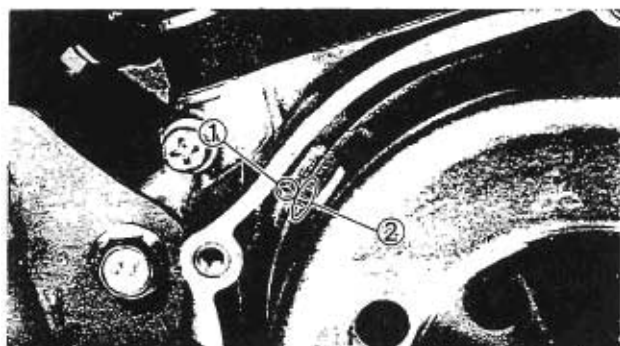

4. Install:
 - Crankcase cover (left)

| | |
|---|--|
|  | Screw (crankcase cover): 10 Nm (1.0 m•kg, 7.2 ft•lb) |
|---|--|

ENGINE OIL LEVEL INSPECTION

NOTE: _____

Position the motorcycle straight up when inspecting the oil level.

1. Place the motorcycle on a level surface.

NOTE: _____

Place the motorcycle on its centerstand if a centerstand is equipped. If not, place a suitable stand under the motorcycle.

2. Inspect:
 - Oil level
 - Oil level low → Add oil to proper level.

| | |
|---|---|
|  | Recommended oil: Air cooled 2-stroke engine oil |
|---|---|

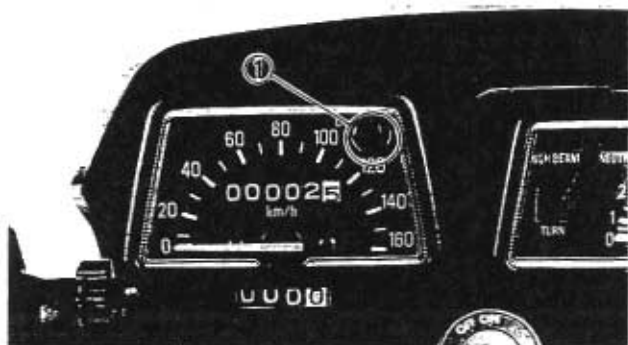
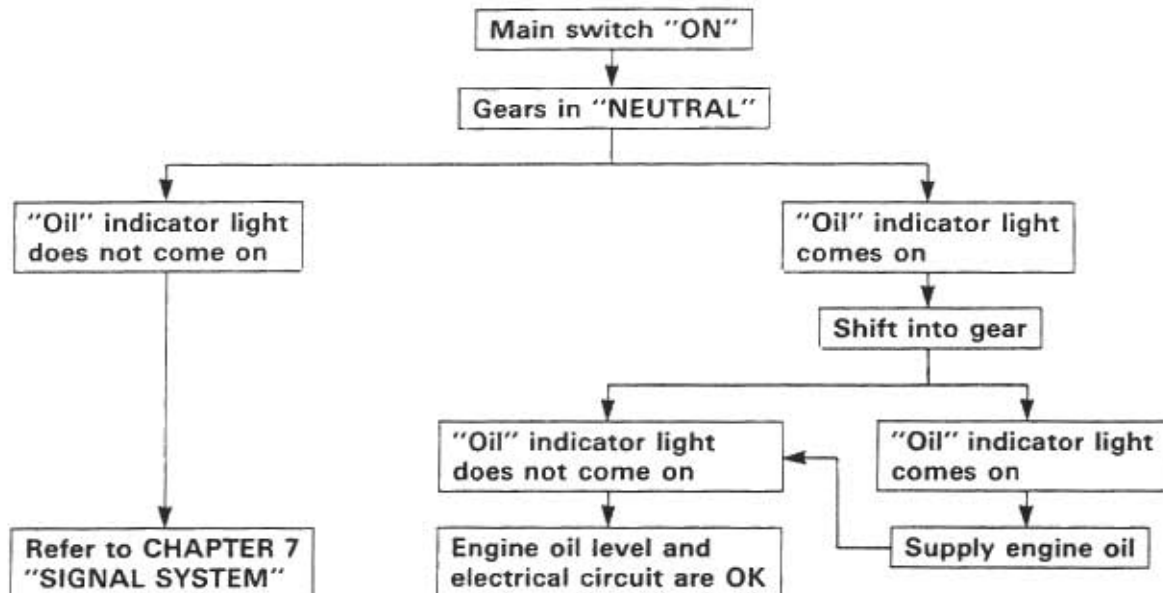

"OIL" INDICATOR LIGHT CHECKING METHOD

**CAUTION:**

Always use the same type of engine oil. Mixing oils may result in a chemical reaction leading to poor performance.

① "OIL" indicator light

NOTE:

If the main switch is turned off after the "OIL" indicator light goes off and immediately turned on again, the "OIL" indicator light may not come on. This is not because of failure.

TRANSMISSION OIL LEVEL INSPECTION NOTE:

Position the motorcycle straight up when inspecting the oil level.

1. Place the motorcycle on a level place.

NOTE:

Place the motorcycle on its centerstand if a centerstand is equipped. If not, place a suitable stand under the motorcycle.

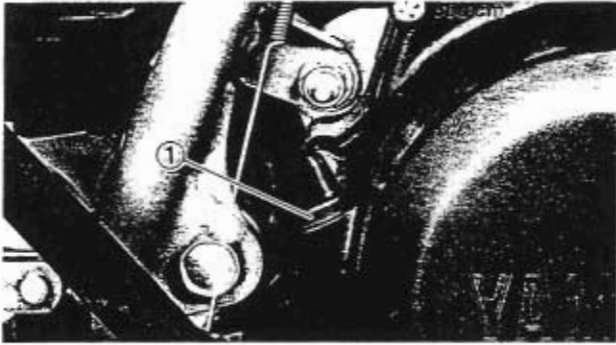

2. Remove:
 - Oil level gauge ①

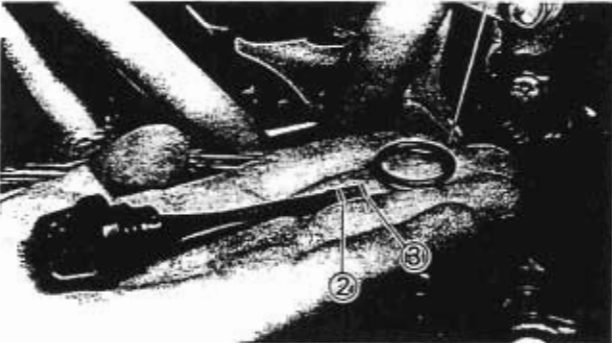

3. Inspect:
 - Oil level

Oil level should be between maximum ② and minimum ③ marks.
Oil level low → Add oil to proper level.

| | |
|--|--|
| | <p>Recommended oil: SAE 10W30 type SE motor oil</p> |
|--|--|

NOTE: _____

- Be sure the motorcycle is positioned straight up when checking the oil level.
- When inspecting the oil level, do not screw the oil level gauge into the crankcase. Insert the gauge lightly.

NOTE: _____

Recommended oil classification: API Service "SE", "SF" type or equivalent (e.g. "SF-SE", "SF-SE-CC", "SF-SE-SD" etc.).

CAUTION: _____

- Do not add any chemical additives. Transmission oil also lubricates the clutch and additives could cause clutch slippage.
- Do not allow foreign material to enter the crankcase.

4. Start the engine and let it warm up for several minutes.
5. Stop the engine and inspect the oil level once again.

NOTE: _____

Wait a few minutes until the oil settles before inspecting the oil level.



6. Install:
 - Oil level gauge

TRANSMISSION OIL REPLACEMENT

1. Start the engine and let it warm up for several minutes.
2. Stop the engine and place an oil pan under the engine.
3. Remove:
 - Oil level gauge ①
 - Drain plug ②
 Drain the transmission case of its oil.

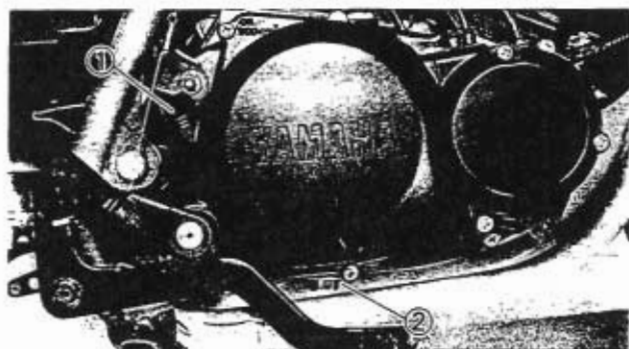

4. Install:
 - Drain plug

| | |
|---|--|
|  | Drain plug: 20 Nm (2.0 m•kg, 14 ft•lb) |
|---|--|

NOTE: _____
 Check the gasket (drain plug). If damaged, replace it with a new one.

5. Fill:
 - Transmission case

| | |
|---|--|
|  | Oil quantity (periodic oil change): 0.60 L (0.53 Imp qt, 0.63 US qt) |
|---|--|

Refer to the "TRANSMISSION OIL LEVEL INSPECTION" section.

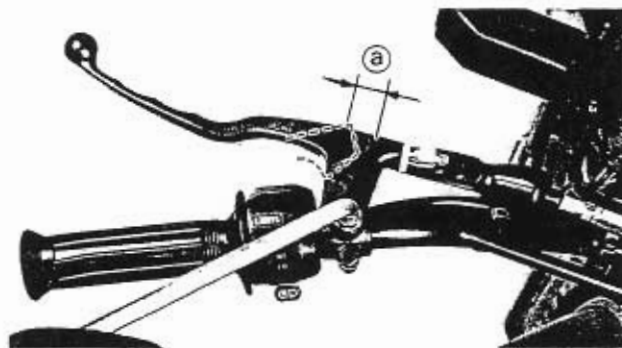

CLUTCH ADJUSTMENT

Cable free play adjustment

1. Check:
 - Clutch cable free play **a**
 - Out of specification → Adjust.



Free play:

2~3 mm (0.08~0.12 in)

At clutch lever pivot

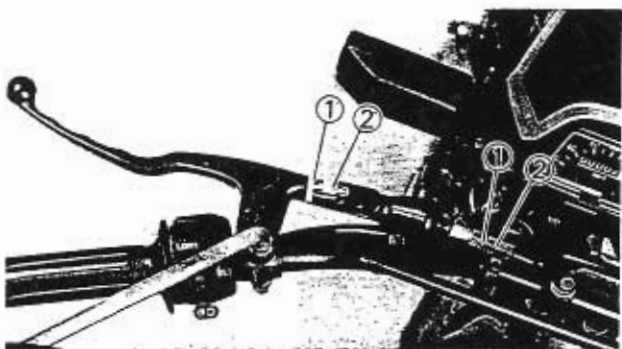

2. Adjust:
 - Clutch cable free play

Adjustment steps:

- Loosen the locknut(s) **1**.
- Turn the adjuster(s) **2** in or out until the specified free play is obtained.

Turning in → Free play is increased.

Turning out → Free play is decreased.

- Tighten the locknut(s).

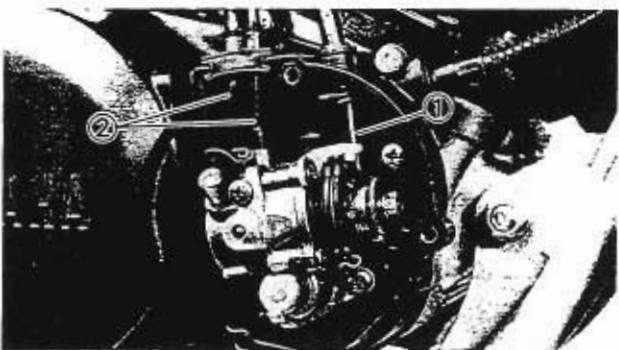

3. Disconnect:

- Autolube pump cable **1**
- Autolube pump hoses **2**

Refer to the "AUTOLUBE PUMP CABLE AND HOSE" section in the CHAPTER 4.

4. Loosen:

- Rear brake adjuster

5. Drain:

- Transmission oil

Refer to the "TRANSMISSION OIL REPLACEMENT" section.

6. Remove:

- Kick crank **1**
- Oil level gauge **2**
- Crankcase cover (right) **3**

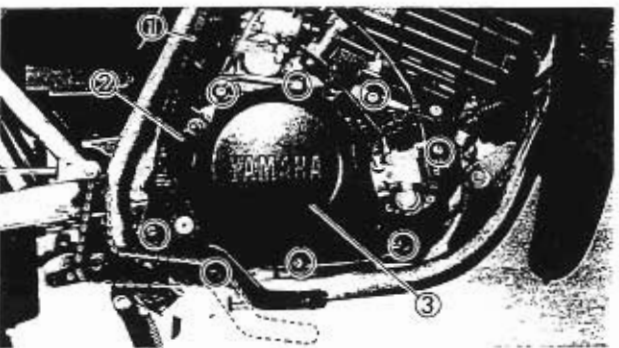

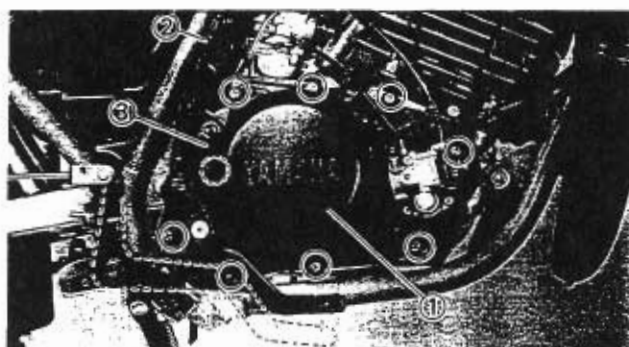
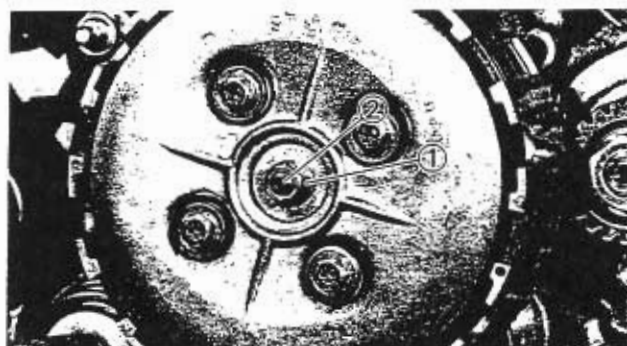

7. Adjust:
- Mechanism free play

Adjustment steps:

- Loosen the locknut (1).
- Push the push lever (3) toward the front of the engine finger until it stops.
- With the push lever in this position, turn the adjuster (2) in or out until the push lever (3) and match mark (4) are aligned.
- Tighten the locknut.



Locknut:
8 Nm (0.8 m•kg, 5.8 ft•lb)

8. Install:
- Crankcase cover (right) (1)
 - Kick crank (2)
 - Oil level gauge (3)



Screw (crankcase cover):
8 Nm (0.8 m•kg, 5.8 ft•lb)
Drain plug (oil):
20 Nm (2.0 m•kg, 14 ft•lb)
Bolt (kick crank):
23 Nm (2.3 m•kg, 17 ft•lb)

NOTE: _____

- When installing the crankcase cover, engage the Autolube pump drive gear with its driven gear as slowly turn the Autolube pump shaft.
- Tighten the screws (crankcase cover) in stage, using a crisscross pattern.
- Install the kick crank so that it does not contact the case.
- Before installing the brake pedal, apply the lithium soap base grease to the brake pedal pivot shaft.

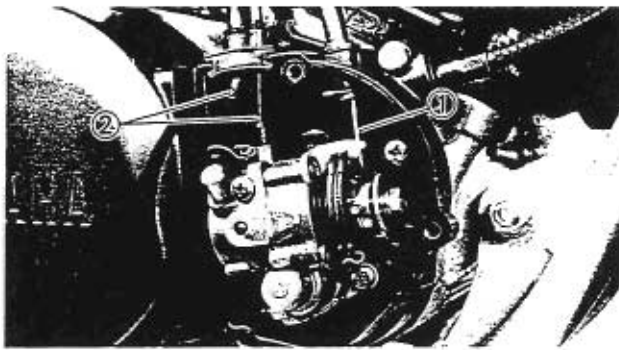

9. Connect:
 - Autolube pump cable ①
 - Autolube pump hoses ②
10. Air bleed:
 - Oil pump and oil hoses
 Refer to the "AUTOLUBE PUMP AIR BLEEDING" section.

11. Fill:
 - Crankcase
 Refer to the "TRANSMISSION OIL REPLACEMENT" section.
12. Connect:
 - Clutch cable
13. Adjust:
 - Clutch cable free play
 Refer to the "CABLE FREE PLAY ADJUSTMENT" section.

AIR FILTER CLEANING

1. Remove:
 - Side cover (left) ①



2. Remove:
 - Air filter case cover ①

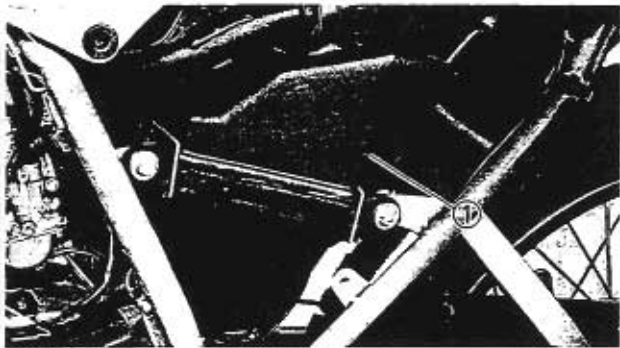

3. Remove:
 - Air filter element ①



CAUTION:

Never operate the engine with the air filter element removed. Unfiltered air will cause rapid wear of engine parts and possible engine damage. Additionally, operation without the filter element will affect carburetor turning with subsequent poor performance and possible engine overheating.

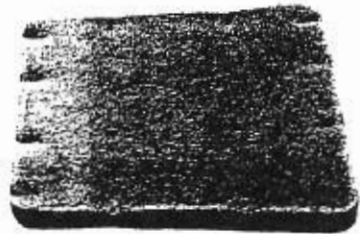

4. Inspect:
- Air filter element
 - Damaged → Replace.

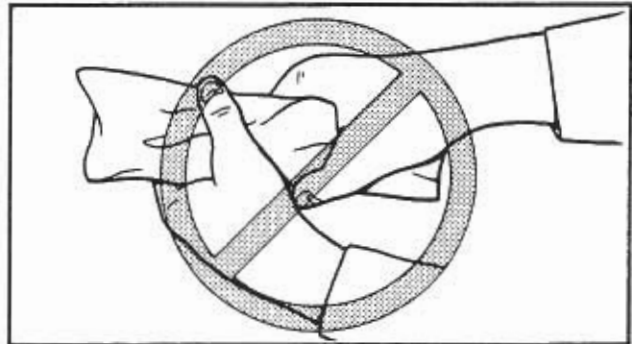
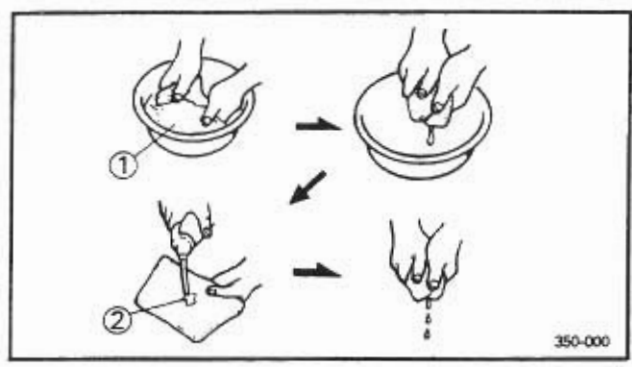

5. Clean:
- Air filter element

Cleaning steps:

- Wash the element gently, but thoroughly in solvent ①.

⚠ WARNING _____

Use parts cleaning solvent only. Never use gasoline or low flash point solvents as they may cause a fire or explosion.

- Squeeze the excess solvent out of the element and let it dry.

CAUTION: _____

Do not twist or wring out the element. This could damage the foam material.

- Apply air cooled oil to the element ②.
- Squeeze out the excess oil.

NOTE: _____

The element should be wet but not dripping.

6. Install:
- Air filter element
 - Air filter case cover
 - Side cover (left)

NOTE: _____

When installing the element in its case, be sure its sealing surface matches the sealing surface of the case so there is no air leak.

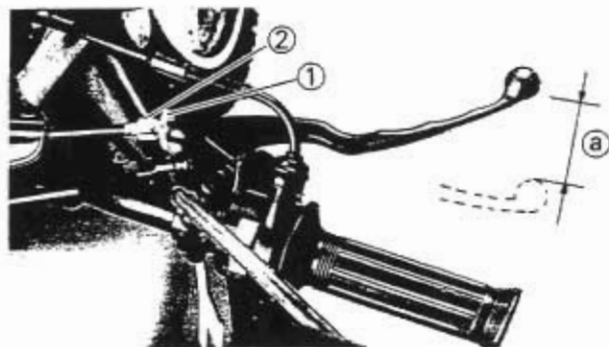

CHASSIS

FRONT BRAKE ADJUSTMENT

1. Check:
 - Brake lever free play (a)
 - Out of specification → Adjust.

| | |
|--|---------------------------|
| | Free play: |
| | 5 ~ 8 mm (0.20 ~ 0.32 in) |
| | At brake lever end |

2. Adjust:
 - Brake lever free play

Adjustment steps:

- Loosen the locknut(s) (1).
- Turn the adjuster(s) (2) in or out until the specified free play is obtained.

| |
|---------------------------------------|
| Turning in → Free play is decreased. |
| Turning out → Free play is increased. |

- Tighten the locknut(s).

CAUTION: _____

Make sure that the brake does not drag after adjusting it.

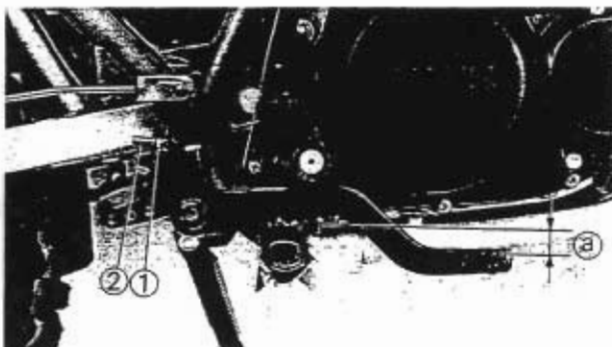

REAR BRAKE ADJUSTMENT

1. Check:
 - Brake pedal height (a)
 - Out of specification → Adjust.

| | |
|--|---------------------|
| | Brake pedal height: |
| | 10 mm (0.4 in) |

2. Adjust:
 - Brake pedal height

Adjustment steps:

- Loosen the locknut (1).
- Turn the adjuster(s) (2) in or out until the specified free play is obtained.

| |
|--|
| Turning in → Pedal height is increased. |
| Turning out → Pedal height is decreased. |

- Tighten the locknut (1).

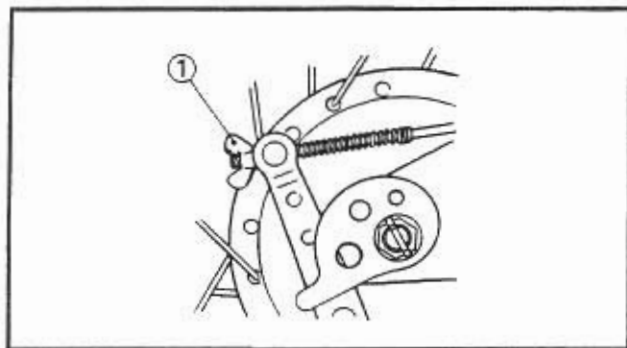
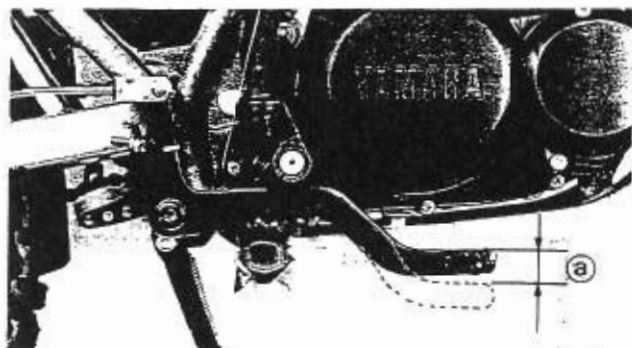

3. Check:

- Brake pedal free play ①
- Out of specification → Adjust.



Free play:

20 ~ 30 mm (0.79 ~ 1.18 in)

Below top of brake pedal

4. Adjust:

- Brake pedal free play

Adjustment steps:

- Turn the adjuster(s) ① in or out until the specified free play is obtained.

Turning in → Free play is increased.

Turning out → Free play is decreased.

CAUTION:

Make sure that the brake does not drag after adjusting it.



DRIVE CHAIN SLACK ADJUSTMENT

NOTE:

Before checking and/or adjusting, rotate the rear wheel several revolutions and check slack at several points to find the tightest point. Check and/or adjust the chain slack with the rear wheel in this "tightest" position.

CAUTION:

Too little of chain slack will overload the engine and other vital parts. Keep the slack within the specified limits.

WARNING

Securely support the motorcycle so there is no danger of it falling over.

1. Place the motorcycle on a level place and hold it in an upright position.

NOTE:

Both wheels should be on the ground without the rider on it.

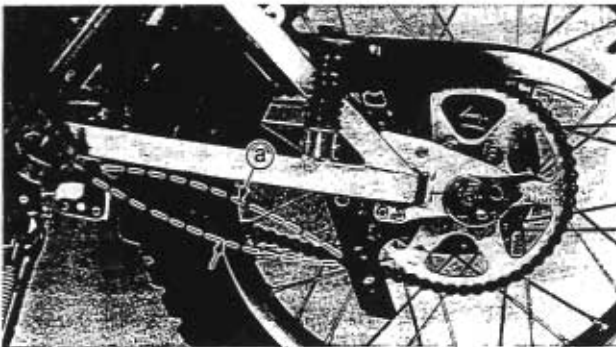

2. Check:

- Drive chain slack (a)
Out of specification → Adjust.



Drive chain slack:

35 ~ 40 mm (1.40 ~ 1.60 in)
with both wheels on ground
without rider

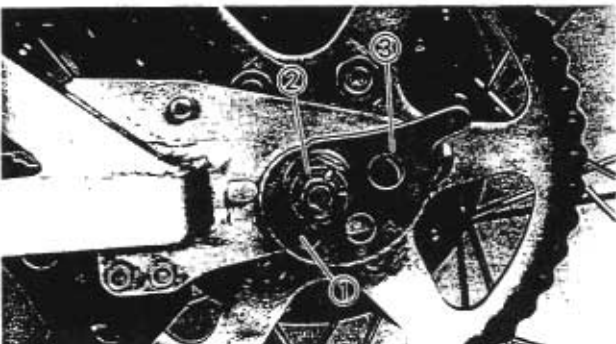

3. Remove:

- Cotter pin (1)

4. Loosen:

- Axle nut (2)



5. Adjust:
- Drive chain slack

Adjustment steps:

- Turn both chain puller(s) ③ clockwise or counterclockwise until the specified slack is obtained.

Turning clockwise → Slack is decreased.

Turning counterclockwise → Slack is increased.

NOTE:

Turn each chain puller exactly the same amount to maintain correct axle alignment. (There are marks on each side of swingarm and on each chain puller. Use them to check for proper alignment.)

- Tighten the axle nut to specification, while pushing up or down on the chain to zero slack.



Axle nut:
85 Nm (8.5 m•kg, 61 ft•lb)

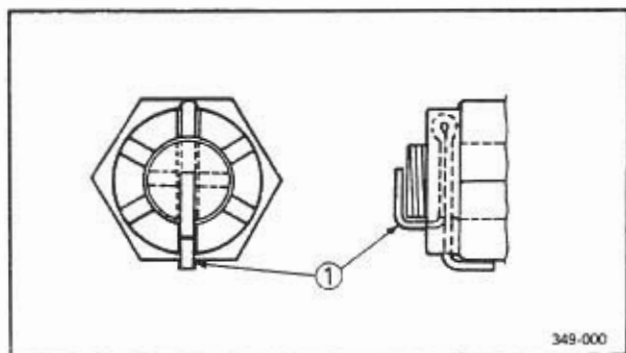

6. Install:
- Cotter pin ①

CAUTION:

Do not loosen the axle nut after torque tightening. If the axle nut groove is not aligned with the cotter pin hole, align groove with the hole by tightening up on the axle nut.

WARNING

Always use a new cotter pin.

7. Adjust:
- Rear brake
Refer to the "REAR BRAKE ADJUSTMENT" section.



DRIVE CHAIN LUBRICATION

The chain consists of many parts that work with each other. If the chain is not maintained properly, it will wear out rapidly. Therefore, form the habit of periodically servicing the chain. This service is especially necessary when riding in dusty conditions.

1. Use any brands of spray type chain lubricant. Remove all dirt and mud from the chain with a brush or cloth. Spray lubricant between both rows of side plates and on all center rollers.
2. To clean the chain, remove the chain from the machine. Dip it in solvent, and clean out as much dirt as possible. Take the chain out of the solvent and dry it. Immediately lubricate the chain to prevent from rusting.



Recommended lubricant:
Yamaha chain and cable lube
or SAE 10W30 motor oil

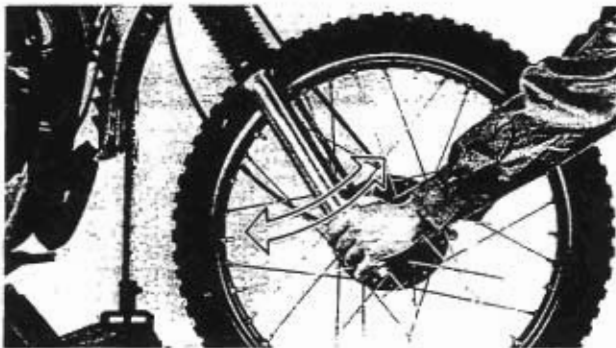

STEERING HEAD ADJUSTMENT

⚠ WARNING

Securely support the motorcycle so there is no danger of it falling over.

1. Elevate the front wheel by placing a suitable stand under the engine.
2. Check:
 - Steering assembly bearings
Grasp the bottom of the forks and gently rock the fork assembly back and forth.
Looseness → Adjust steering head.



3. Remove:

- Front wheel

Refer to the "FRONT WHEEL" section in CHAPTER 6.

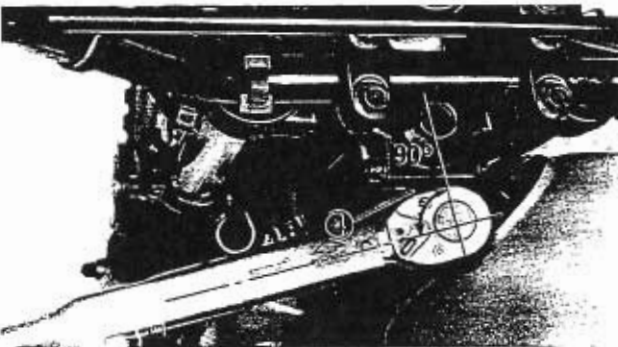
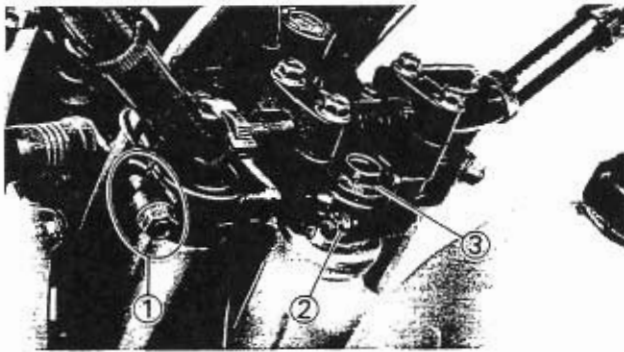

4. Adjust:

- Steering head

Adjustment steps:

- Loosen the bolt ① (steering shaft) and bolt ② (handlebar crown) and flange bolt ③ (front fork).
- Pull up the handlebar crown.
- Tighten the ring nut using the Ring nut wrench ④.

NOTE: _____

Set the torque wrench to the Ring nut wrench so that they form a right angle.



Ring nut wrench:
P/N. 90890-01403



Ring nut (initial tightening):
38 Nm (3.8 m•kg, 27 ft•lb)

- Loosen the ring nut one turn.
- Retighten the ring nut using the Ring nut wrench.

⚠ WARNING _____

Avoid over-tightening.



Ring nut (final tightening):
6 Nm (0.6 m•kg, 4.3 ft•lb)

NOTE: _____

Recheck the steering head by turning the steering from left to right.

If steering is bound, loosen the ring nut slightly.

- Pull down the handlebar crown.



- Tighten the bolt (steering shaft) and bolt (handlebar crown) and flange bolt (front fork).



Bolt (steering shaft):
54 Nm (5.4 m•kg, 39 ft•lb)
Bolt (handlebar crown):
23 Nm (2.3 m•kg, 17 ft•lb)
Bolt (front fork):
23 Nm (2.3 m•kg, 17 ft•lb)

5. Install:
- Front wheel
Refer to the "FRONT WHEEL" section in CHAPTER 6.

FRONT FORK INSPECTION

⚠ WARNING

Securely support the motorcycle so there is no danger of it falling over.

1. Place the motorcycle on a level place.
2. Check:
 - Inner tube ①
Scratch/Damage → Replace.
 - Oil seal ②
Excessive oil leakage → Replace.
3. Hold the motorcycle on upright position and apply the front brake.
4. Check:
 - Operation
Pump the front fork up and down for several times.
Unsmooth operation → Repair.





REAR SHOCK ABSORBER ADJUSTMENT

⚠ WARNING

Securely support the motorcycle so there is no danger of it falling over.

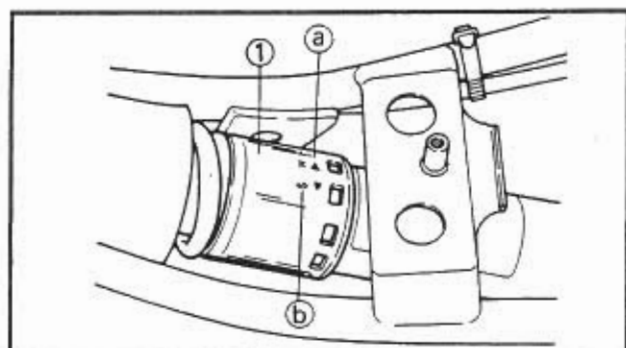

Spring preload

1. Adjust:

- Spring preload
Turn the adjuster ① to direction ① a or ① b.

Turning toward ① a → Spring preload is harder.

Turning toward ① b → Spring preload is softer.

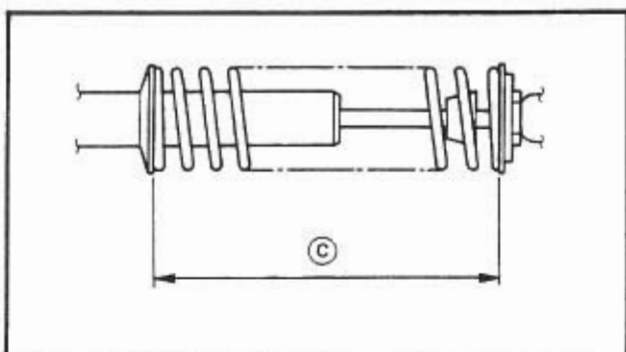

Adjuster position ① c:

Standard: 249 mm (9.96 in)

Minimum: 245 mm (9.80 in)

Maximum: 253 mm (10.12 in)

CAUTION:

Never turn the adjuster beyond the maximum or minimum setting.

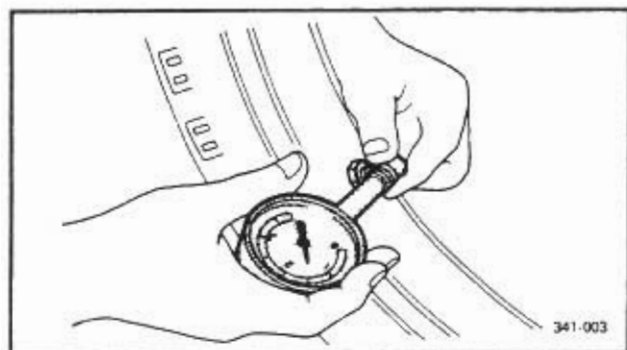

TIRE INSPECTION

1. Measure:

- Tire pressure
Out of specification → Adjust.

⚠ WARNING

Tire inflation pressure should be checked and adjusted when the temperature of the tire equals the ambient air temperature. Tire inflation pressure must be adjusted according to total weight of cargo, rider, passenger, and accessories (fairing, saddlebags, etc. if approved for this model), and vehicle speed.

⚠ WARNING

Proper loading of your motorcycle is important for the handling, braking, and other performance and safety characteristics of your motorcycle. Do not carry loosely packed items that can shift. Securely pack your heaviest items close to the center of the motorcycle, and distribute the weight evenly from side to side. Properly adjust the suspension for your load, and check the condition and pressure of your tires. **NEVER OVERLOAD YOUR MOTORCYCLE.** Make sure the total weight of the cargo, rider, passenger, and accessories (fairing, saddlebags, etc. if approved for this model) does not exceed the maximum load of the motorcycle. Operation of an overloaded motorcycle could cause tire damage, an accident, or even injury.

| | |
|---|-----------------|
| Basic weight: With oil and full fuel tank | 107 kg (236 lb) |
| Maximum load* | 213 kg (470 lb) |

| Cold tire pressure | Front | Rear |
|-----------------------------------|---|---|
| Up to 90 kg (198 lb) load | 150 kPa (1.5 kg/cm ² , 21 psi) | 200 kPa (2.0 kg/cm ² , 29 psi) |
| 90 kg (198 lb) – Maximum load* | 150 kPa (1.5 kg/cm ² , 21 psi) | 230 kPa (2.3 kg/cm ² , 33 psi) |
| Off-road riding | 150 kPa (1.5 kg/cm ² , 21 psi) | 200 kPa (2.0 kg/cm ² , 28.5 psi) |

*Load is the total weight of cargo, rider, passenger, and accessories.

2. Inspect:
- Tire surfaces
- Wear/Damage → Replace.

| | |
|---|---|
|  | Minimum tire tread depth (front and rear): |
| | 0.80 mm (0.03 in) |

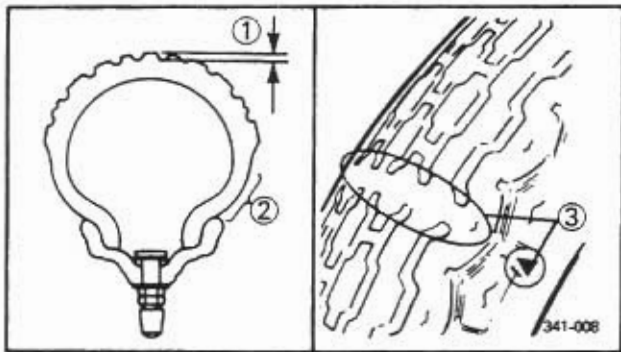

- ① Tread depth
- ② Side wall
- ③ Wear indicator

⚠ WARNING

- It is dangerous to ride with a worn-out tire. When a tire tread begins to show lines, replace the tire immediately.
- Patching a punctured tube is not recommended. If it is absolutely necessary to do so, use great care and replace the tube as soon as possible with a good quality replacement.
- Do not use tubeless tires on a wheel designed for tube type tires only. Tire failure and personal injury may result from sudden deflation.

| |
|--|
| Tube type wheel → Tube type tire only |
| Tubeless type wheel → Tube type or tubeless tire |

- Be sure to install the correct tube when using tube type tires.

**⚠ WARNING**

After extensive tests, the tires mentioned below have been approved by Yamaha motor Co., Ltd. for this model. No guarantee for handling characteristics can be given if tire combinations other than what is approved are used on this motorcycle. The front and rear tires should be of the same manufacture and design.

FRONT:

| Manufacture | Size | Type |
|-------------|-------------|-------|
| BRIDGESTONE | 2.75-21-4PR | TW15 |
| YOKOHAMA | 2.75-21-4PR | Y-968 |

REAR:

| Manufacture | Size | Type |
|-------------|-------------|-------|
| BRIDGESTONE | 4.10-18-4PR | TW12 |
| YOKOHAMA | 4.10-18-4PR | Y-968 |

⚠ WARNING

- After mounting a tire, ride conservatively to allow proper tire to rim seating. Failure to do so may cause an accident resulting in motorcycle damage and possible operator injury.
- After a tire repair or replacement, be sure to torque/tighten the valve stem locknut ① to specification.



Valve stem locknut:
1.5 Nm (0.15 m•kg, 1.1 ft•lb)

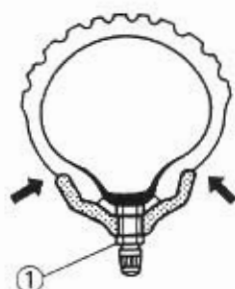

341-009



WHEEL INSPECTION

1. Inspect:
 - Wheels
Damage/Bends → Replace.

NOTE: _____

Always balance the wheel when a tire or wheel has been changed or replaced.

⚠ WARNING _____

Never attempt to make any repairs to the wheel.

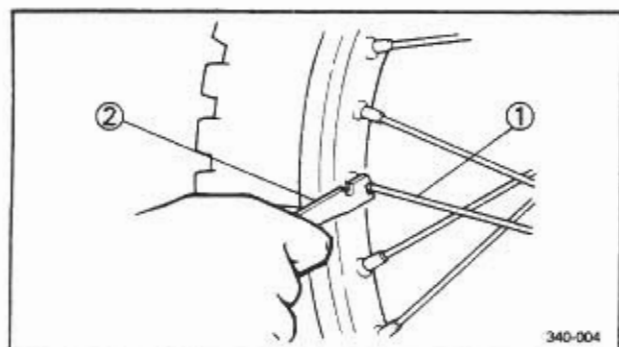

SPOKES INSPECTION AND TIGHTENING

1. Inspect:
 - Spokes ①
Bend/Damage → Replace.
Loose spoke → Tighten.

2. Tighten:
 - Spokes ①

② Spoke wrench

NOTE: _____

Be sure to retighten these spokes before and after Break-in.

| | |
|--|--|
| | Nipple: 2 Nm (0.2 m•kg, 1.4 ft•lb) |
|--|--|



ELECTRICAL

BATTERY INSPECTION

- Remove:
 - Side cover (right)
- Inspect:
 - Fluid level
Fluid level should be between upper ① and lower ② level marks.
Fluid level low → Add to proper level.

CAUTION:

Refill with distilled water only. Tap water contains minerals which are harmful to a battery.

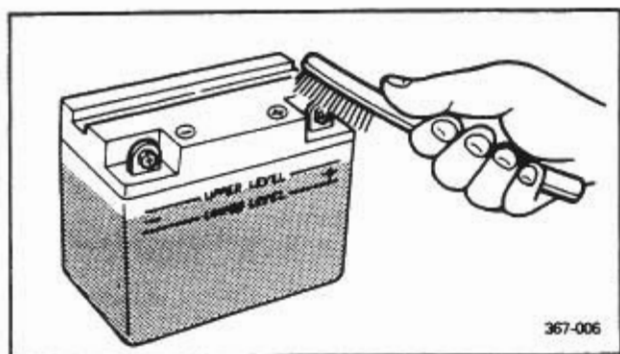
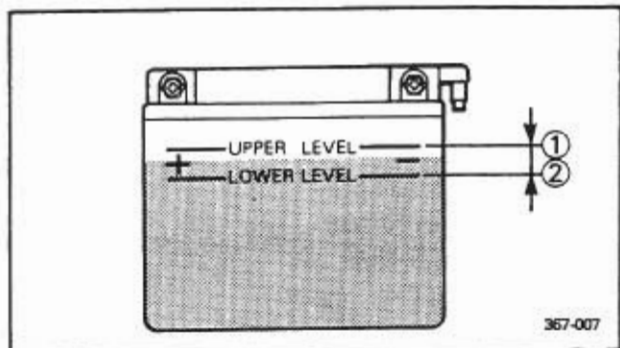

- Inspect:
 - Battery terminal
Dirty terminal → Clean with wire brush.
Poor connection → Correct.

NOTE:

After cleaning the terminals, apply a light coat of grease to the terminals.

- Inspect:
 - Breather hose
Obstruction → Remove.
Damage → Replace.

CAUTION:

When inspecting the battery, be sure the breather hose is routed correctly. If the breather hose is positioned in such a way as to allow battery electrolyte or gas to exit onto the frame, structural and cosmetic damage to the motorcycle may occur.

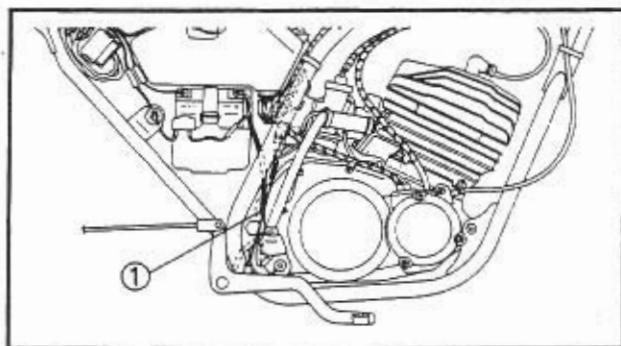

5. Connect:
- Breather hose ①
Be sure the hose is properly attached and routed.

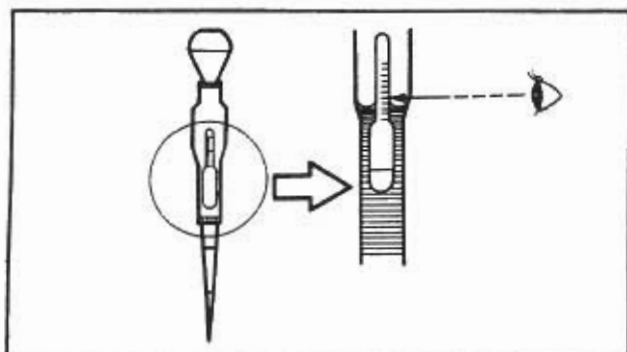

6. Check:
- Specific gravity
Less than 1.280 → Recharge battery.

Charging current:
0.3 amps/10 hrs
Specific gravity:
1.280 at 20°C (68°F)

Replace the battery if:

- Battery voltage will not rise to a specific value or bubbles fail to rise even after many hours of charging.
- Sulfation of one or more cells occurs, as indicated by the plates turning white, or an accumulation of material exists in the bottom of the cell.
- Specific gravity readings after a long, slow charge indicate one cell to be lower than the rest.
- Warpage or buckling of plates or insulators is evident.



CAUTION: _____
Always charge a new battery before using it to ensure maximum performance.

**⚠ WARNING**

Battery electrolyte is dangerous; it contains sulfuric acid and therefore is poisonous and highly caustic.

Always follow these preventive measures:

- Avoid bodily contact with electrolyte as it can cause severe burns or permanent eye injury.
- Wear protective eye gear when handling or working near batteries.

Antidote (EXTERNAL):

- SKIN— Flush with water.
- EYES— Flush with water for 15 minutes and get immediate medical attention.

Antidote (INTERNAL):

- Drink large quantities of water or milk followed with milk of magnesia, beaten egg, or vegetable oil. Get immediate medical attention.

Batteries also generate explosive hydrogen gas, therefore you should always follow these preventive measures:

- Charge batteries in a well-ventilated area.
- Keep batteries away from fire, sparks, or open flames (e.g., welding equipment, lighted cigarettes, etc.)
- DO NOT SMOKE When charging or handling batteries.

KEEP BATTERIES AND ELECTROLYTE OUT OF REACH OF CHILDREN.

7. Install:

- Side cover (right)

FUSE INSPECTION**CAUTION:**

Always turn off the main switch when checking or replacing a fuse. Otherwise, short-circuiting may occur.

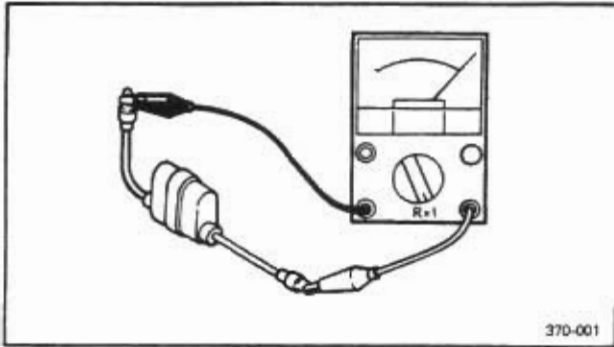
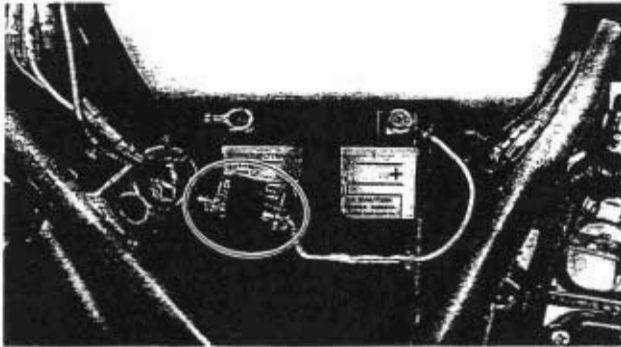

1. Remove:
 - Side cover (right) ①

2. Inspect:
 - Fuse

Inspection steps:

- Connect the Pocket tester to the fuse and check it for continuity.

NOTE: _____

Set the tester selector to " $\Omega \times 1$ " position.

| | |
|--|---|
|  | Pocket tester: P/N. 90890-03112 |
|--|---|

- If the tester is indicated at ∞ . Replace the fuse.
- *****

3. Replace:
 - Blown fuse

Replacement steps:

- Turn off the ignition.
- Install a new fuse of proper amperage.
- Turn on the switches to verify operation of the effected electrical device.
- If the fuse immediately blows again, check the electrical circuit.

⚠ WARNING _____

Never use a fuse with a rating other then specified. Never use other material in place of a fuse. An improper fuse may cause damage to the electrical system, to possibly cause a fire, the lighting and/or ignition.

- *****
4. Install:
 - Side cover (right)

HEADLIGHT BEAM ADJUSTMENT/ HEADLIGHT BULB REPLACEMENT

INSP
ADJ



HEADLIGHT BEAM ADJUSTMENT

1. Adjust:
 - Headlight beam (vertical)
Turn the adjuster ① in or out.

Turning in → Headlight beam moves raise.

Turning out → Headlight beam moves lower.

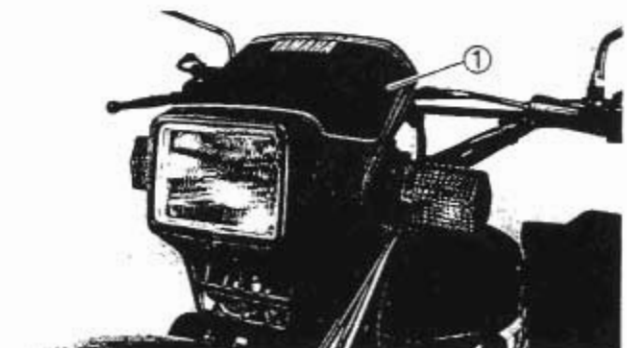

HEADLIGHT BULB REPLACEMENT

1. Remove:
 - Headlight cover ①



2. Remove:
 - Headlight lens unit ①

3. Disconnect:
 - Headlight lead
 - Auxiliary light lead



4. Remove:
 - Bulb holder ①
 - Bulb ②

NOTE: _____

Turn the bulb holder counterclockwise and remove the defective bulb.

A Turn

⚠ WARNING _____

Keep flammable products and your hands away from the bulb while it is on, it will be hot. Do not touch the bulb until it cools down.

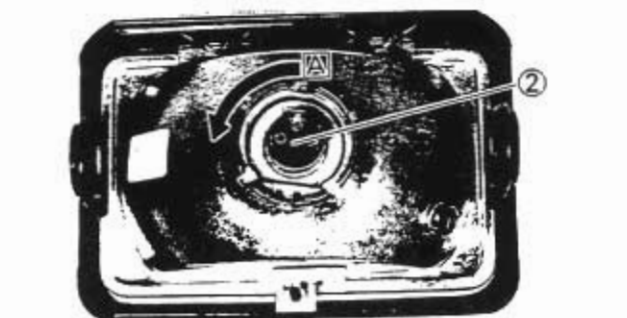



5. Install:

- Bulb (new) ①

Secure the new bulb with the bulb holder.

CAUTION:

Avoid touching glass part of bulb and keep it free from oil. Otherwise, transparency of glass, bulb life and illuminates flux will be adversely affected. If oil gets on the bulb, clean it with a cloth moistened with alcohol or lacquer thinner.

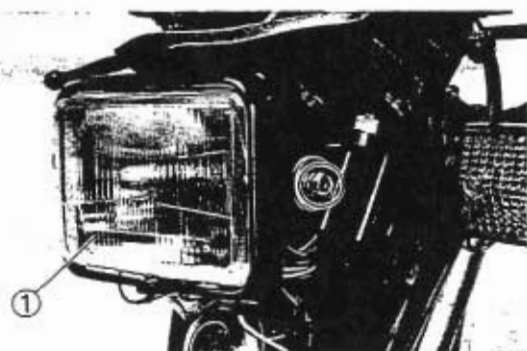

6. Connect:

- Auxiliary light lead
- Headlight lead

7. Install:

- Headlight lens unit ①

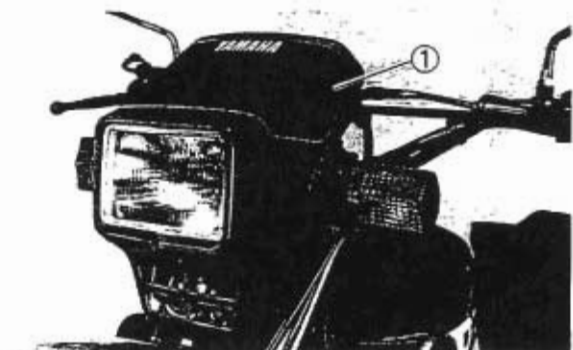

8. Install:

- Headlight cover ①

9. Adjust:

- Headlight beam

Refer to the "HEADLIGHT BEAM ADJUSTMENT" section.



CHAPTER 4. ENGINE OVERHAUL

| | |
|--|---------|
| ENGINE REMOVAL | C-16 |
| SIDE COVERS | C-16 |
| SEAT | C-16 |
| TRANSMISSION OIL | C-16 |
| EXHAUST PIPE | C-16 |
| CARBURETOR | C-16 |
| AUTOLUBE PUMP CABLE AND HOSE | C-16 |
| CLUTCH CABLE | D-1 |
| TACHOMETER CABLE | D-1 |
| ENERGY INDUCTION | D-1 |
| BATTERY LEADS | D-1 |
| SPARK PLUG LEADS | D-1 |
| CDI MAGNETO LEADS | D-1 |
| DRIVE SPROCKET | D-1 |
| ENGINE REMOVAL | D-1 |
| ENGINE DISASSEMBLY | D-2 |
| CYLINDER HEAD | D-2 |
| PISTON | D-2 |
| CLUTCH | D-2 |
| PRIMARY DRIVE GEAR | D-3 |
| CLUTCH PUSH LEVER | D-4 |
| KICK AXLE AND KICK IDLE GEAR | D-4 |
| SHIFT SHAFT | D-4 |
| CDI MAGNETO | D-5 |
| CRANKCASE | D-5 |
| SHIFTER AND TRANSMISSION | D-6 |
| CRANKSHAFT | D-6 |
| AUTOLUBE PUMP ASSEMBLY | D-6 |
| INSPECTION AND REPAIR | D-7 |
| CYLINDER HEAD | D-7 |
| CYLINDER AND PISTON | D-7 |
| PISTON RINGS | D-8 |
| PISTON PIN AND BEARING | D-9 |
| CLUTCH | D-9 |
| PRIMARY DRIVE GEAR | D-9 |
| SHIFTER | D-10 |
| TRANSMISSION | D-11 |
| KICK STARTER | D-11 |
| SHIFT SHAFT | D-12 |
| CRANKSHAFT | D-12 |
| AUTOLUBE PUMP | D-12 |
| TACHOMETER GEAR | D-13 |
| CRANKCASE | D-13 |



| | |
|---|------|
| ENGINE ASSEMBLY AND ADJUSTMENT | D-14 |
| CRANKCASE (LEFT) | D-14 |
| CRANKSHAFT | D-14 |
| TRANSMISSION AND SHIFTER | D-15 |
| CRANKCASE (RIGHT) | D-15 |
| CDI MAGNETO | E-1 |
| SHIFT SHAFT | E-2 |
| KICK AXLE AND KICK IDLE GEAR | E-3 |
| PRIMARY DRIVE GEAR | E-3 |
| CLUTCH | E-4 |
| CYLINDER AND PISTON | E-6 |
| CYLINDER HEAD | E-7 |
| REMOUNTING ENGINE | E-7 |



ENGINE OVERHAUL

ENGINE REMOVAL

NOTE: _____

It is not necessary to remove the engine in order to remove the following components:

- Cylinder head
 - Cylinder
 - Piston and piston ring
 - Clutch
 - Primary drive gear
 - Kick axle
 - CDI magneto
-

SIDE COVERS

1. Remove:

- Side cover (right)
- Side cover (left)

NOTE: _____

To open the side cover lock, insert the key in the lock and turn it clockwise.

SEAT

1. Remove:

- Seat ①

TRANSMISSION OIL

1. Drain:

- Transmission oil

Refer to the "TRANSMISSION OIL REPLACEMENT" section in the CHAPTER 3.

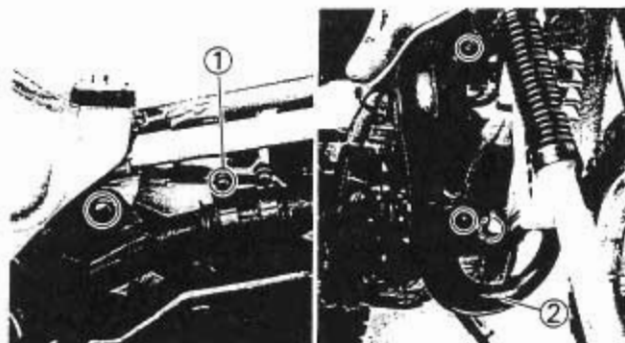

**EXHAUST PIPE**

1. Loosen:
 - Screw (muffler joint) ①
2. Remove:
 - Gasket (exhaust pipe)
 - Exhaust pipe ②

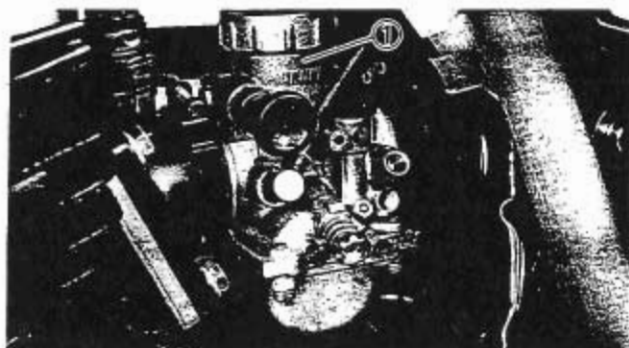
**CARBURETOR**

1. Disconnect:
 - Carburetors ①
(from intake manifold)

NOTE:

Cover the carburetor with a clean rag to prevent dirt or foreign material from entering the carburetor.

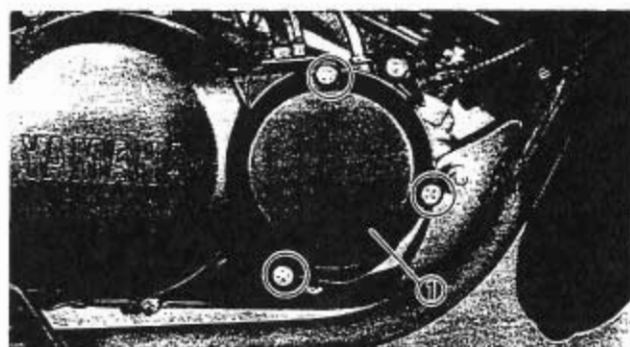
**AUTOLUBE PUMP CABLE AND HOSE**

1. Remove:
 - Autolube pump cover ①
 - Gasket

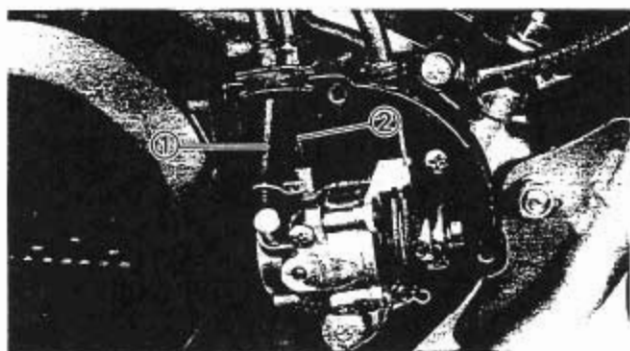

2. Disconnect:
 - Oil delivery hose ①, ②
(from autolube pump and hose guide)

NOTE:

Plug the oil hose so that oil will not run out of the oil tank.

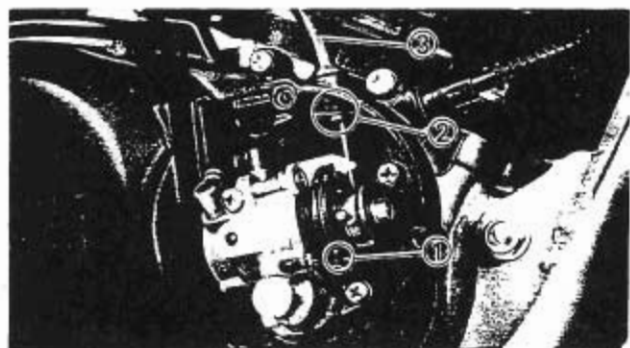

3. Remove:
 - Stopper clip (pump cable) ①
 - Clip (pump cable outer) ②
4. Disconnect:
 - Autolube pump cable ③

NOTE:

Turn the pump pulley counterclockwise by finger to make the pump cable loose enough for its end to be removed from the pulley.

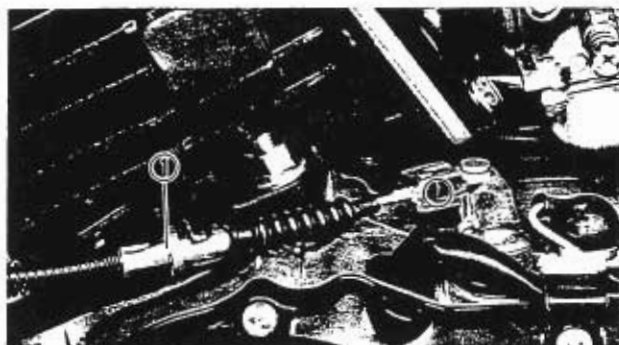
**CLUTCH CABLE**

1. Remove:
 - Clutch cable (engine side) ①

NOTE: _____

Straighten the holder portion of push lever axle.

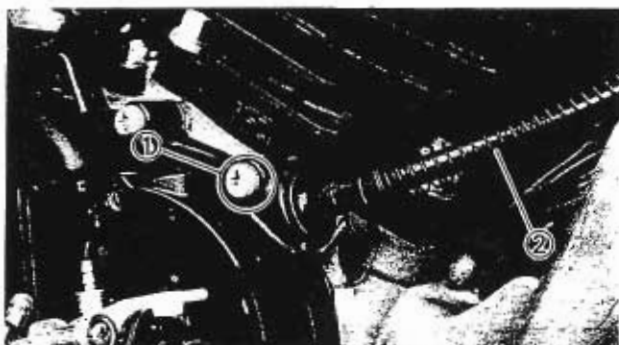
**TACHOMETER CABLE**

1. Remove:
 - Screw ①
 - Tachometer cable ②

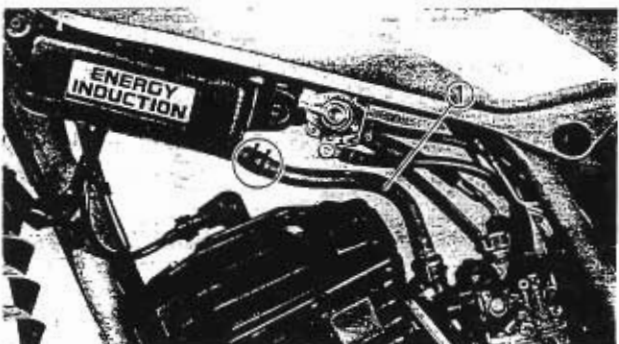
**ENERGY INDUCTION**

1. Remove:
 - Energy induction hose ①

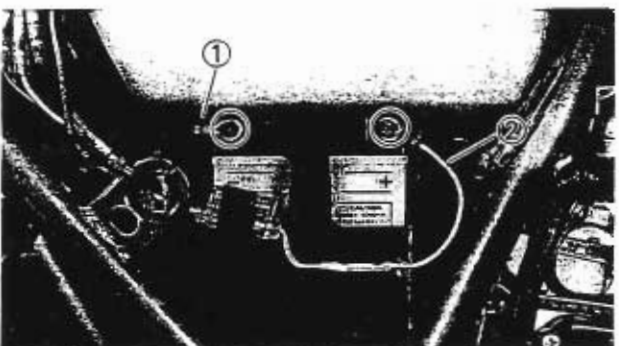
**BATTERY LEADS**

1. Disconnect:
 - Battery leads

CAUTION: _____

Disconnect the negative lead ① first and then disconnect the positive lead ②.

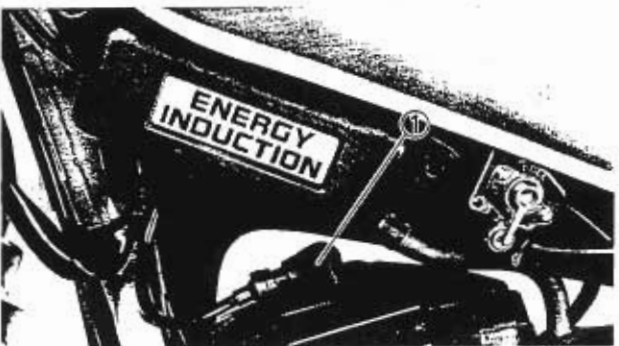
**SPARK PLUG LEADS**

1. Disconnect:
 - Spark plug lead ①

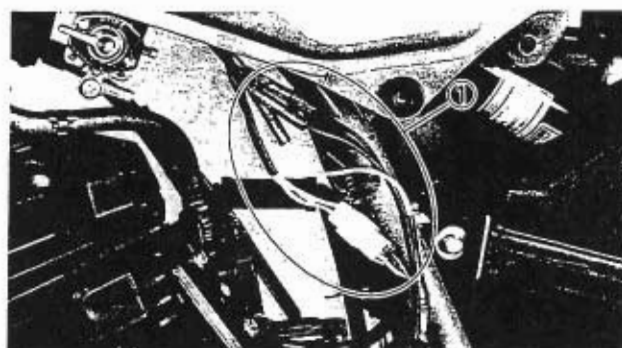
**CDI MAGNETO LEADS**

1. Disconnect:
 - CDI magneto leads ①

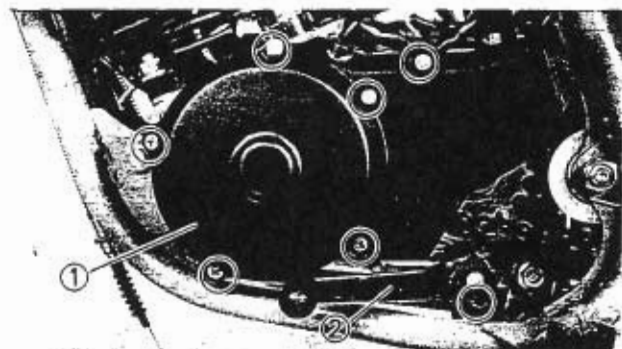
**DRIVE SPROCKET**

1. Remove:
 - Crankcase cover (left) ①
 - Gasket (crankcase cover)
 - Change pedal ②

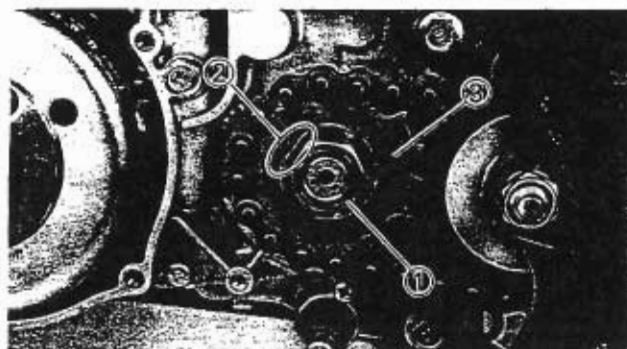

2. Straighten:
 - Lock washer tab
3. Remove:
 - Nut ①
 - Lock washer ②
 - Drive sprocket ③

NOTE:

Loosen the nut while applying the rear brake.

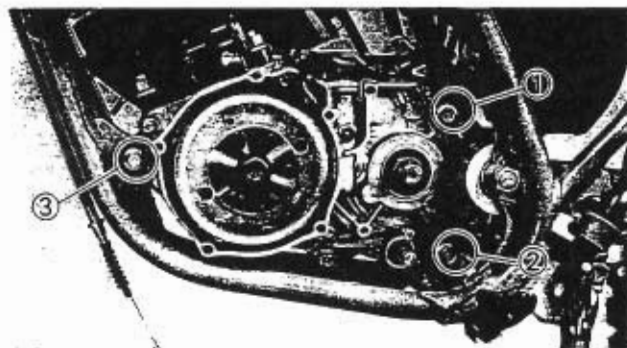
**ENGINE REMOVAL**

1. Remove:
 - Mounting bolt ① (rear—upper)
 - Mounting bolt ② (rear—lower)
 - Mounting bolt ③ (front)

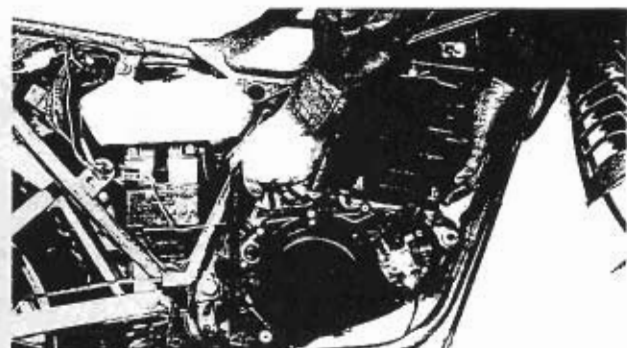

2. Remove:
 - Engine assembly
(from right side)



ENGINE DIASSEMBLY

CYLINDER HEAD

NOTE:

With the engine mounted, the cylinder head can be maintained by removing the following parts.

- Side covers (right and left)
- Fuel tank
- Exhaust pipe

1. Remove:

- Spark plug ①



2. Remove:

- Cylinder head
- Gasket (cylinder head)

NOTE:

- Loosen the nuts starting with the highest numbered one.
- Loosen each nut 1/4 turn, and remove them after all nuts are loosened.



3. Remove:

- Cylinder ①
- Gasket (cylinder)
- Dowel pins

NOTE:

- Loosen each nut 1/4 turn, and remove them after all nuts are loosened.

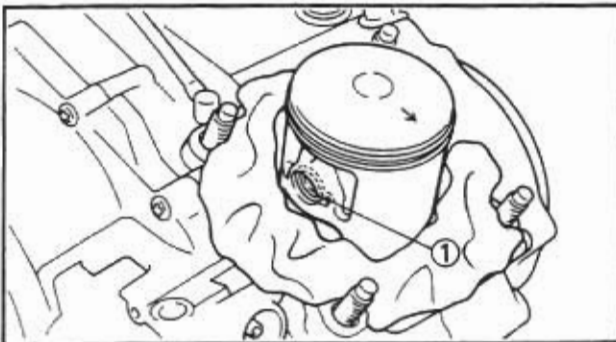
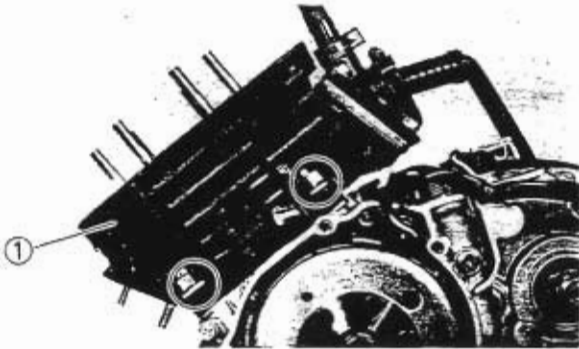

PISTON

1. Remove:

- Piston pin clip ①

NOTE:

- Before removing piston pin circlip, cover crankcase with a clean rag to prevent circlip from falling into crankcase cavity.

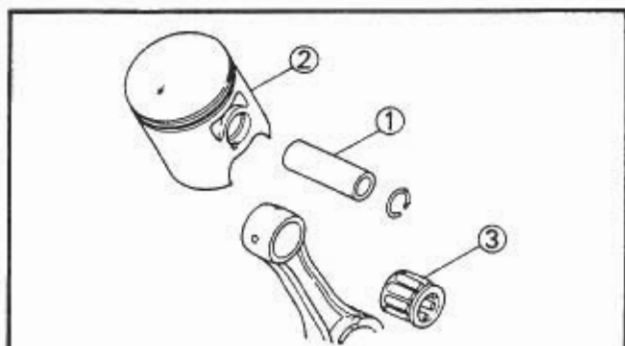

2. Remove:

- Piston pin ①
- Piston ②
- Small end bearing ③

NOTE: _____

Before removing the piston pin, deburr the clip groove and pin hole area. If the piston pin groove is deburred and piston pin is still difficult to remove, use Piston Pin Puller.



Piston pin puller:
90890-01304

CAUTION: _____

Do not use a hammer to drive the piston pin out.

CLUTCH

NOTE: _____

With the engine mounted, the clutch assembly can be maintained by the following parts.

- Brake pedal
- Autolube pump cable and hoses
- Kick crank
- Crankcase cover (right)

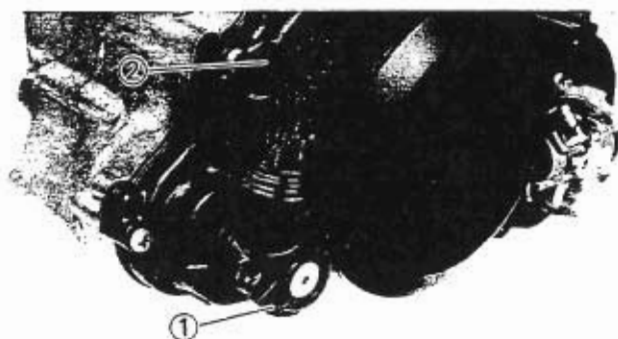

1. Remove:

- Kick crank ①
- Oil level gauge ②

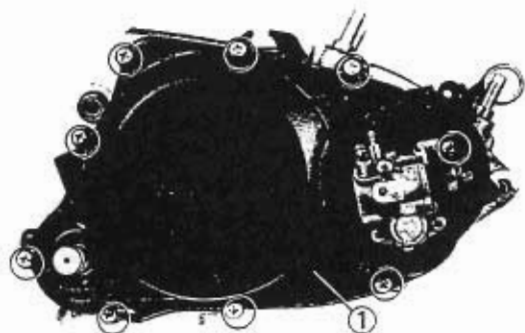

2. Remove:

- Crankcase cover ① (right)

NOTE: _____

Working in a crisscross pattern, loosen the bolts 1/4 turn each. Remove them after all are loosened.

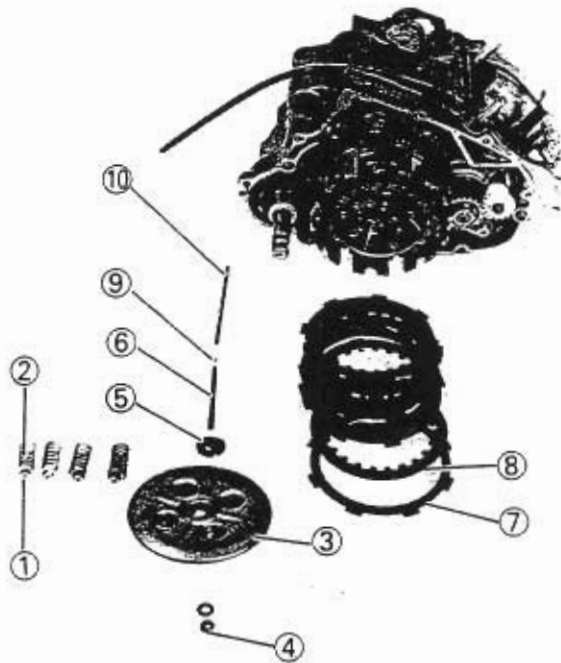

3. Remove:

- Bolts ①
- Clutch springs ②
- Pressure plate #1 ③
- Nut (push rod) ④
- Pressure plate #2 ⑤
- Push rod #1 ⑥
- Friction plate ⑦
- Clutch plate ⑧
- Ball ⑨
- Push rod #2 ⑩

NOTE:

- Working in a crisscross pattern, loosen the bolts 1/4 turn each. Remove them after all are loosened.
- The clutch boss contains a built-in damper beneath the clutch plate. It is not necessary to remove the wire circlip and disassemble the built-in damper unless there is serious clutch chattering.

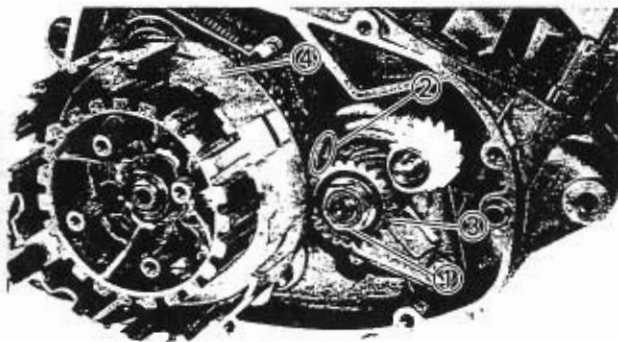

4. Loosen:

- Nut ① (primary drive gear)

NOTE:

- Place a folded fragment of aluminum ② between the teeth of the drive gear ③ and driven gear ④ to lock them.

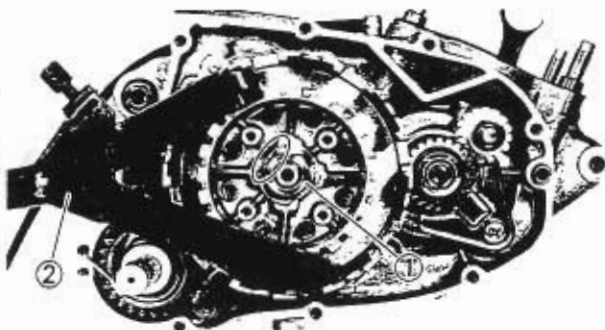

5. Straighten:

- Lock washer tab

6. Loosen:

- Nut ① (clutch boss)

NOTE:

- Loosen the nut (clutch boss) while holding the clutch boss with universal clutch holder ②.



Universal clutch holder:
P/N. 90890-04086

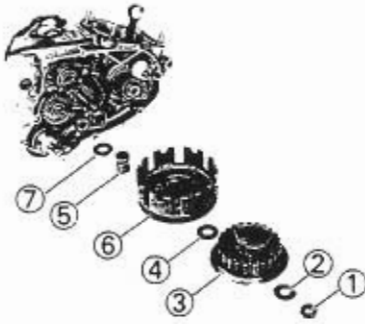

7. Remove:

- Nut ① (clutch boss)
- Lock washer ②
- Clutch boss assembly ③
- Plain washer ④
- Spacer ⑤
- Clutch housing ⑥
- Thrust plate ⑦

PRIMARY DRIVE GEAR**NOTE:**

With the engine mounted, the primary drive gear can be maintained by removing the following parts.

- Brake pedal
- Autolube pump cable and hoses
- Kick crank
- Crankcase cover (right)
- Clutch

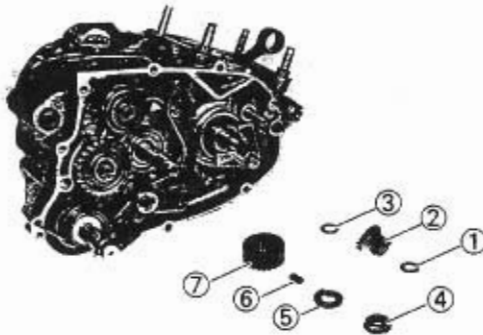

1. Remove:

- Washer ①
- Drive gear ② (tachometer cable)
- Washer ③
- Nut ④
- Spring washer ⑤
- Straight key ⑥
- Primary drive gear ⑦

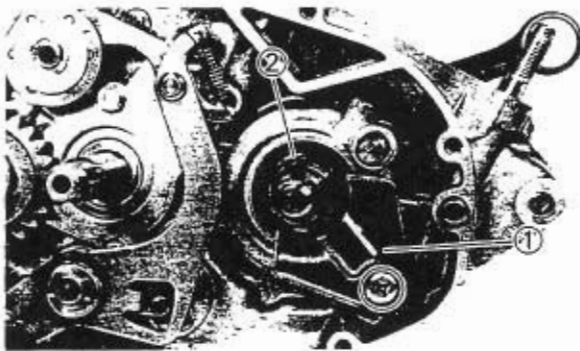

2. Remove:

- Oil seal retainer ①
- Spacer collar ②

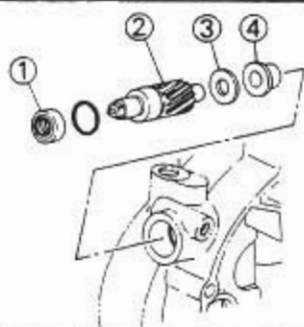

3. Remove:

- Oil seal ①
- Drive gear ② (tachometer cable)
- Washer ③
- Bush ④

CLUTCH PUSH LEVER

1. Remove:

- Stopper bolt ①

2. Unhook:

- Return spring (push lever) ②

3. Remove:

- Push lever (clutch) ③
- Return spring ②
- Washer ④

KICK AXLE AND KICK IDLE GEAR

NOTE:

With the engine mounted, the kick axle and kick idle gear can be maintained by removing the following parts.

- Brake pedal
- Autolube pump cable and hoses
- Kick crank
- Crankcase cover (right)
- Primary drive gear
- Clutch

1. Remove:

- Circlip ①
- Washer ②
- Kick idle gear ③
- Washer ④
- Circlip ⑤

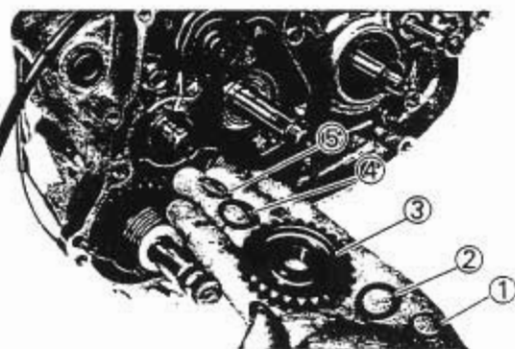

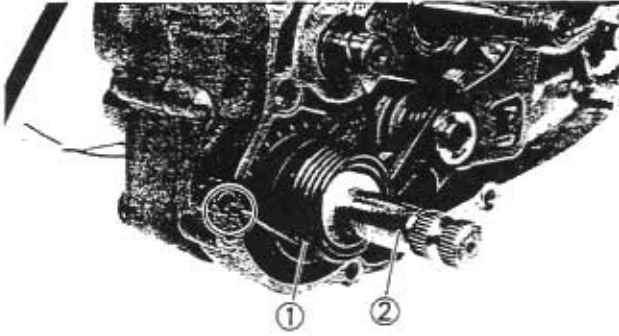

2. Unhook:
 - Return spring (kick axle) ①
3. Remove:
 - Kick axle ②

SHIFT SHAFT

NOTE:

With the engine mounted, the shift shaft can be maintained by the following parts.

- Brake pedal
- Autolube pump cable and hoses
- Kick crank
- Crankcase cover (right)
- Clutch

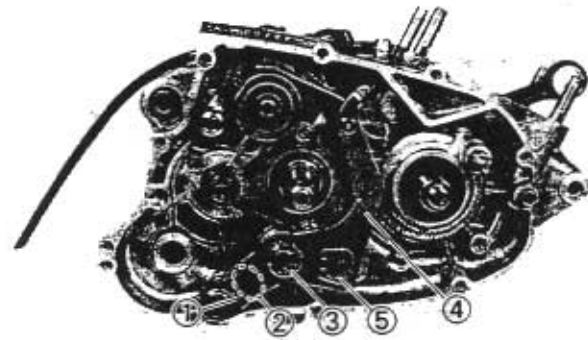

1. Remove:
 - Shift shaft ①
 - Roller ②
 - Circlip ③
 - Shift lever ④
 - Spring ⑤

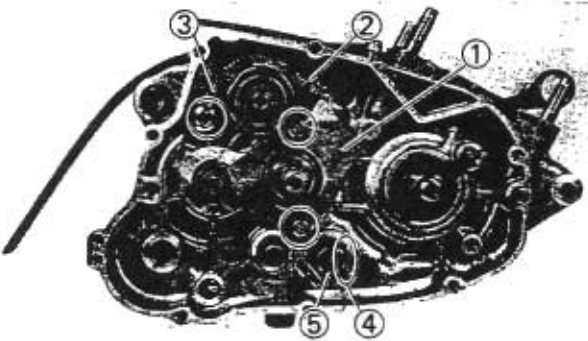

2. Straighten:
 - Lock washer
3. Remove:
 - Plate ①
 - Spring ②
 - Stopper lever ③
 - Lock washer ④
 - Nut ⑤

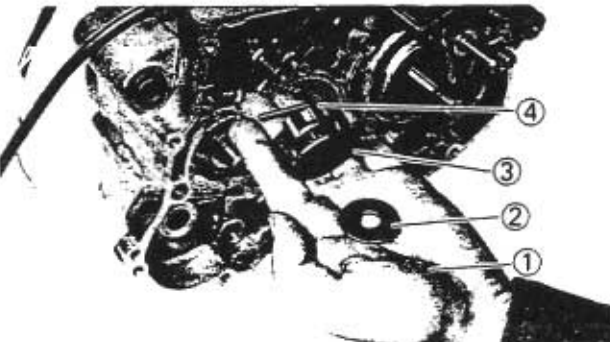

4. Remove:
 - Circlip ①
 - Washer ②
 - Segment ③
 - Pin ④



CDI MAGNETO

NOTE:

With the engine mounted, CDI magneto can be maintained by removing the following parts.

- Crankcase cover (left)

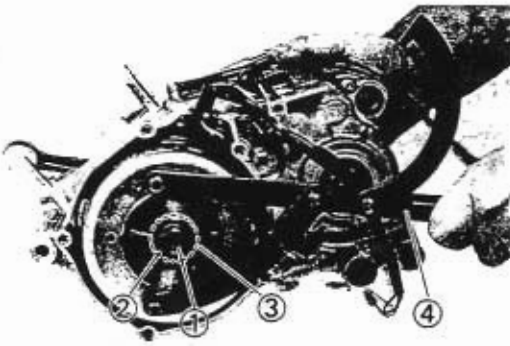

1. Remove:

- Nut (rotor) ①
- Spring washer ②
- Plain washer ③

NOTE:

Loosen the nut (rotor) ① while holding the rotor by the universal rotor holder ④.



Universal rotor holder:
P/N. 90890-01235

2. Remove:

- Rotor ①

NOTE:

Remove the rotor ① while pushing back the rotor the flywheel puller ②.



Flywheel puller:
P/N. 90890-01189

3. Disconnect:

- Neutral switch lead ①

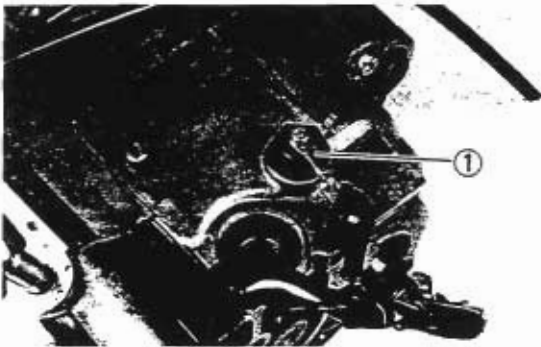

4. Remove:

- Stator ①
- Woodruff key ②

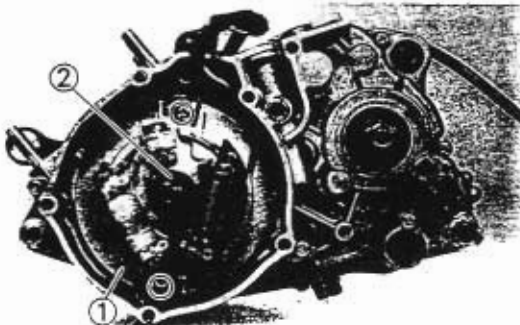

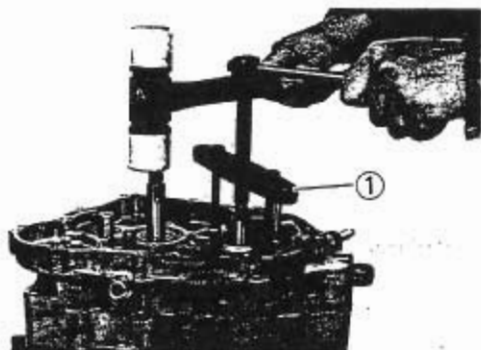
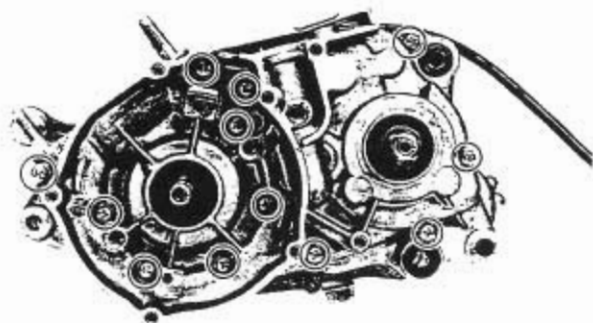
**CRANKCASE**

1. Remove:

- Crankcase (right)

NOTE:

- Loosen the bolts starting with the highest numbered one.
- Loosen each bolt 1/4 turn, and remove them after all bolts are loosened.

Removal steps:

- Attach the crankcase separating tool ①.



Crankcase separating tool:
P/N. 90890-01135

NOTE:

Fully tighten the tool holding bolts, but make sure the tool body is parallel with the case. If necessary, one screw may be backed out slightly to level tool body.

- As pressure is applied, alternately tap on the front engine mounting boss, transmission shafts and shift cam.
- Then, remove the crankcase (right).

CAUTION:

- Use soft hammer to tap on the case half.
- Tap only on reinforced portions of case.
- Do not tap on gasket mating surface.
- Work slowly and carefully.
- Make sure the case halves separate evenly. If one end "hangs up", take pressure off the push screw, realign and start over. If the cases do not separate, check for a remaining case screw or fitting.
- Do not force.

2. Remove:

- Dowel pins ①
- Damper collar ②

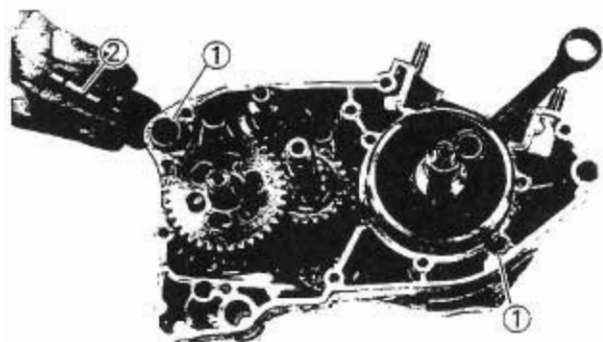

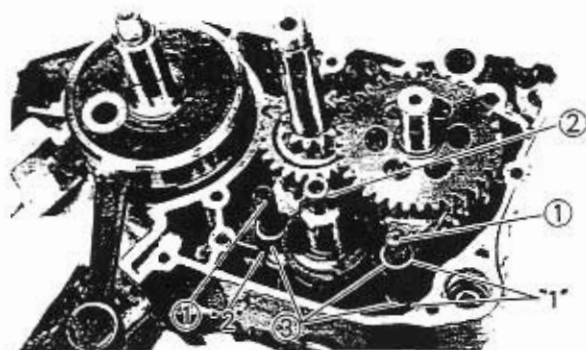
**SHIFTER AND TRANSMISSION**

1. Remove:

- Guide bars ①
- Shift cam ②
- Shift forks ③

NOTE:

Note the position of each part. Pay particular attention to the location and direction of shift forks.

2. Remove:

- Transmission assembly

Tap lightly on the transmission drive axle with a soft hammer.

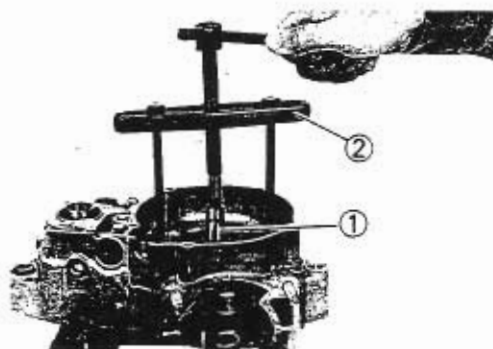
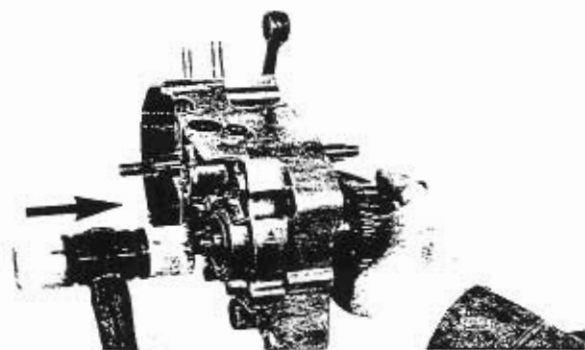
**CRANKSHAFT**

1. Remove:

- Crankshaft ①

NOTE:

- Remove the crankshaft by the Crankcase separating tool ②.



Crankcase Separating Tool:
P/N. 90890-01135

- Fully tighten the tool holding bolts, but make sure the tool body is parallel with the case. If necessary, one screw may be backed out slightly to level tool body.

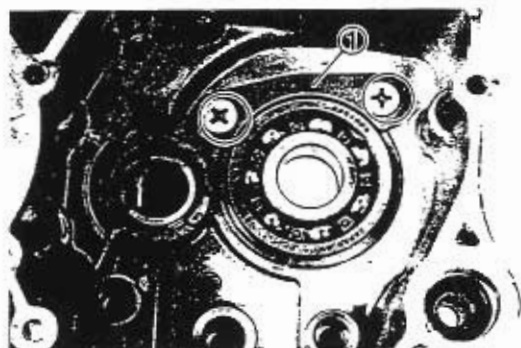

2. Remove:

- Bearing retainer ①

**AUTOLUBE PUMP ASSEMBLY****NOTE:**

With the engine mounted, the autolube pump assembly can be maintained by removing the following parts.

- Brake pedal
- Autolube pump cable and hoses
- Kick crank
- Crankcase cover (right)

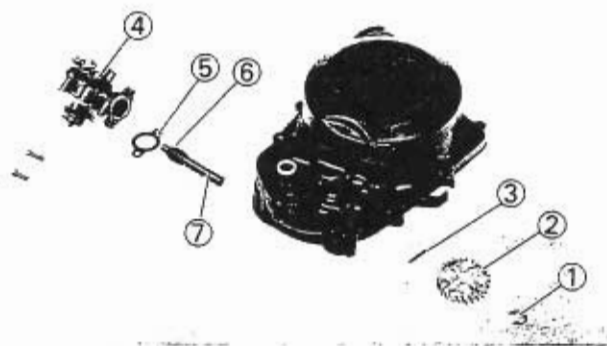
**1. Remove:**

- Circlip ①
- Drive gear (Autolube pump) ②
- Pin ③
- Autolube pump ④
- Gasket ⑤
- Washer ⑥
- Drive shaft (Autolube pump) ⑦

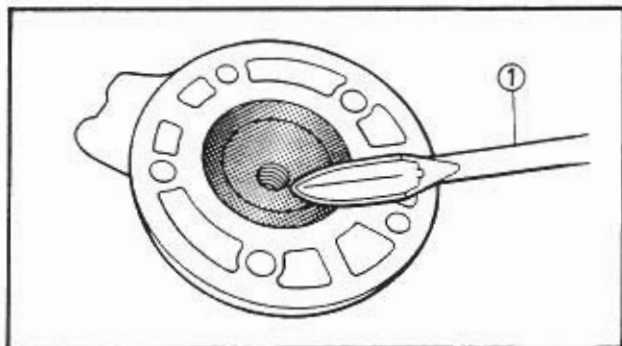

INSPECTION AND REPAIR CYLINDER HEAD

1. Eliminate:

- Carbon deposits
(from combustion chamber)
Use a rounded scraper ①.

NOTE:

Do not use a sharp instrument and avoid damaging or scratching:

- Spark plug threads

2. Inspect:

- Cylinder head
Scratches/Damage → Replace.

3. Measure:

- Cylinder head warpage
Out of specification → Resurface.

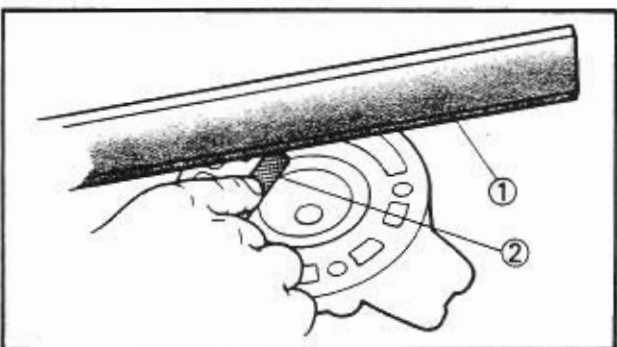

Warpage limit:
0.05 mm (0.002 in)

Warpage measurement and resurfacement step:

- Attach a straight edge ① and a thickness gauge ② on the cylinder head.
- Measure the warpage.
- If the warpage is out of specification, resurface the cylinder head.
- Place a 400–600 grit wet sandpaper on the surface plate, and resurface the head using a figure-eight sanding pattern.

NOTE:

Rotate the head several times to avoid removing too much material from one side.

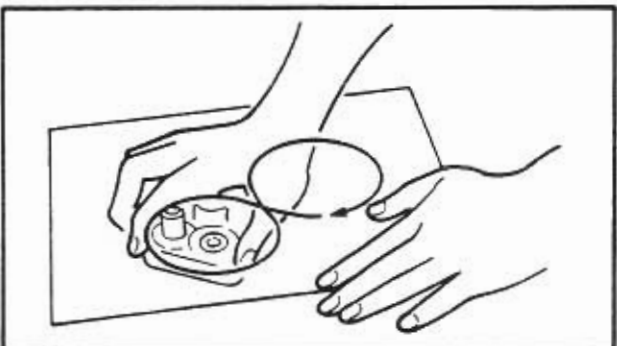

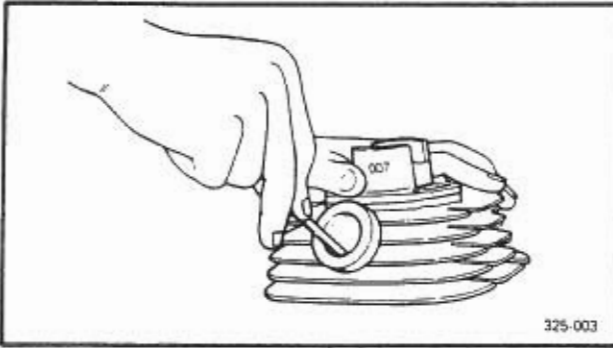
**CYLINDER AND PISTON**

1. Eliminate:

- Carbon deposits
Use a rounded scraper.

NOTE:

Do not use a sharp instrument and avoid damaging or scratching.

2. Inspect:

- Cylinder wall
Wear/Scratches → Rebore or replace.

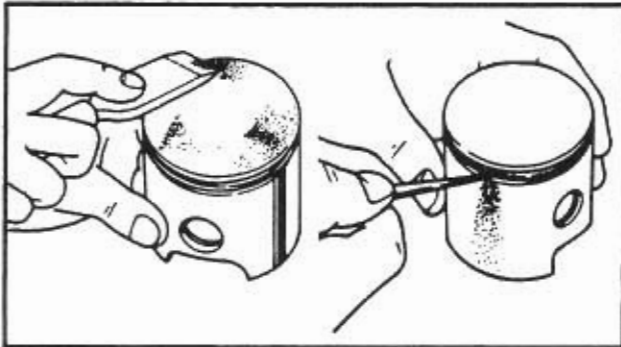

3. Eliminate:

- Carbon deposits
(from piston crown and ring grooves)

4. Inspect:

- Piston crown
Burrs/Nicks/Damage → Replace.

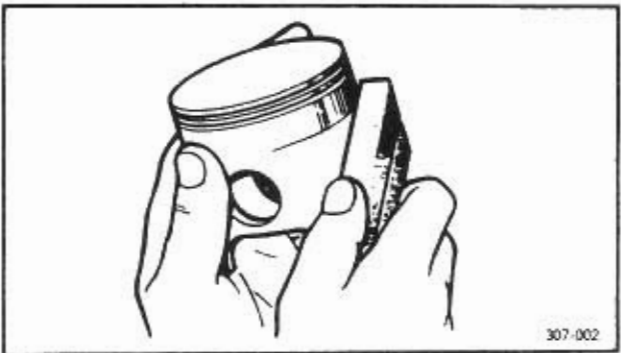

5. Eliminate:

- Score marks and lacquer deposits
(from piston wall)
Use a 600 ~ 800 grit wet sandpaper.

NOTE:

Sand in a crisscross pattern. Do not sand excessively.

6. Inspect:

- Piston wall
Wear/Scratches/Damage → Replace.

7. Measure:

- Piston-to-cylinder clearance

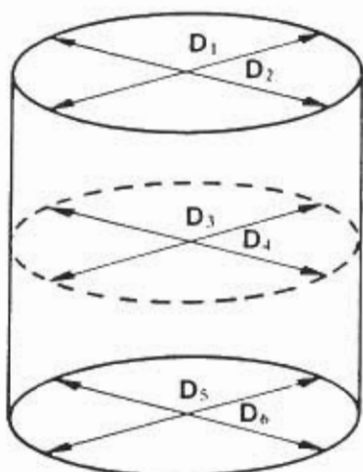

Measurement steps:

First step:

- Measure the cylinder bore "C" with a cylinder bore gauge.

NOTE:

Measure the cylinder bore "C" in parallel to and at right angle to the crankshaft. Then, find the average of the measurements.

| | |
|-------------------|--|
| Cylinder bore "C" | 66.00 – 66.02 mm (2.598 – 2.599 in) |
| < Wear limit > | < 66.1 mm (2.602 in) > |
| Taper limit "T" | 0.05 mm (0.002 in) |
| Out of round "R" | 0.01 mm (0.0004 in) |

"C" = Maximum D

"T" = (Maximum D₁, or D₂)
– (Maximum D₅ or D₆)

"R" = (Maximum D₁, D₃ or D₅)
– (Minimum D₂, D₄ or D₆)

- If out of specification, rebore or replace cylinder, and replace piston and piston rings as a set.

Second step:

- Measure the piston skirt diameter "P" with a micrometer.

Ⓐ 10 mm (0.4 in) from the piston bottom edge.

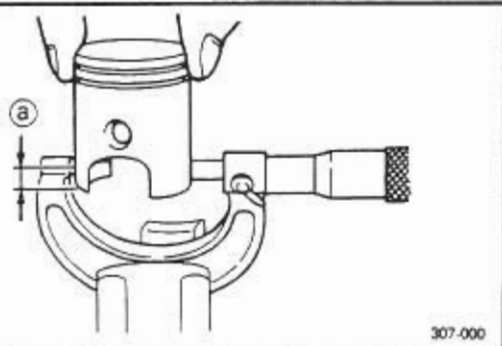

307-000

| | Piston size P |
|------------|--|
| Standard | 65.94 – 66.00 mm (2.596 – 2.598 in) |
| Oversize 1 | 66.25 mm (2.608 in) |
| Oversize 2 | 66.50 mm (2.618 in) |

- If out of specification, replace piston and piston rings as a set.

**Third step:**

- Calculate the piston-to-cylinder clearance with following formula:

$$\text{Piston-to-cylinder clearance} = \text{Cylinder bore "C"} - \text{Piston skirt diameter "P"}$$

- If out of specification, rebore or replace cylinder, and replace piston and piston rings as a set.

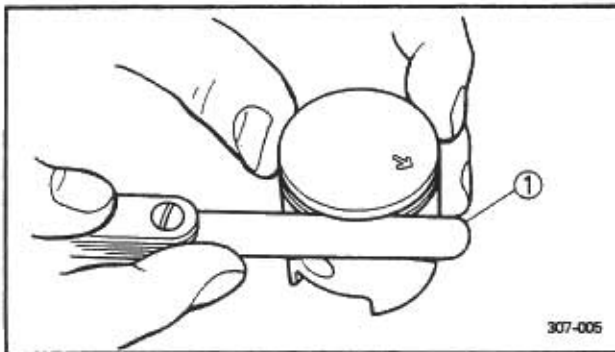

Piston-to-cylinder clearance:
 0.040 ~ 0.045 mm
 (0.0016 ~ 0.0018 in)
 Limit: 0.1 mm (0.004 in)

**PISTON RINGS****1. Measure:**

- Side clearance
 Out of specification → Replace piston and/or rings.
 Use a feeler gauge ①.

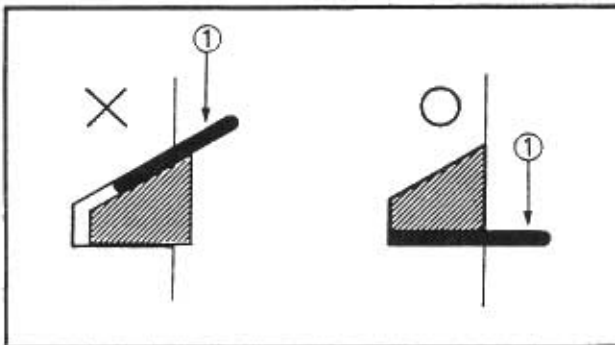

Side clearance:
Top ring
 0.03 ~ 0.05 mm
 (0.0012 ~ 0.0020 in)
2nd ring
 0.03 ~ 0.05 mm
 (0.0012 ~ 0.0020 in)

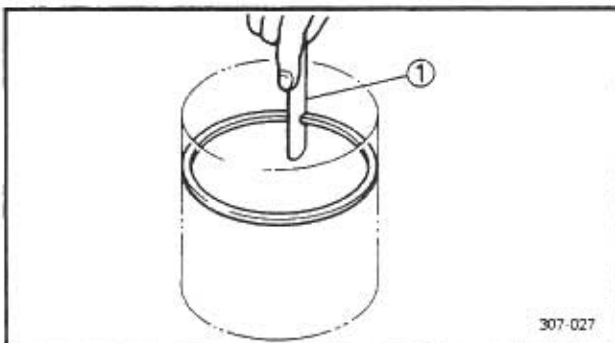
**2. Install:**

- Piston ring
 (into the cylinder)
 Push the ring with the piston crown.

3. Measure:

- End gap
 Out of specification → Replace rings as a set.
 Use a feeler gauge ①.



End gap:

Top ring

0.3 ~ 0.5 mm (0.012 ~ 0.020 in)

2nd ring

0.3 ~ 0.5 mm (0.012 ~ 0.020 in)

Oversize piston ring

| | |
|------------|----|
| Oversize 1 | 25 |
| Oversize 2 | 50 |

PISTON PIN AND BEARING

1. Inspect:

•Piston pin

Blue discoloration/groove → Replace, then inspect lubrication system.

2. Measure:

•Piston pin-to-piston clearance

Measurement steps:

- Measure the piston pin outside diameter (a).
If out of specification, replace the piston pin.



Outside diameter (piston pin):

15.995 ~ 16.000 mm

(0.639 ~ 0.640 in)

- Measure the piston inside diameter (b).
- Calculate the piston pin-to-piston clearance with following formula:

Piston pin-to-piston clearance =

Bore size (piston pin) (b) -

Outside diameter (piston pin) (a)

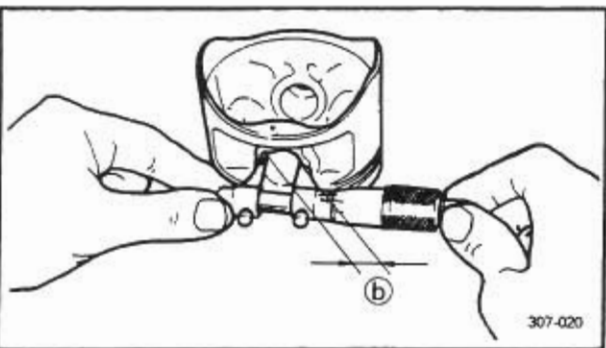
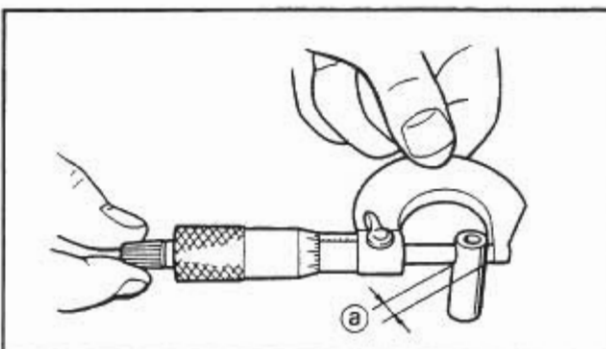
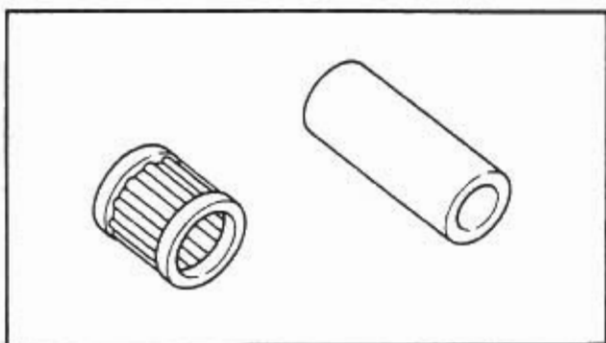

307-020



- If out of specification, replace the piston.



Piston pin-to-piston clearance:

0.004 – 0.020 mm

(0.00016 – 0.0008 in)

Limit: 0.07 mm (0.028 in)

3. Inspect:

- Bearing (piston pin)
Pitting/Damage → Replace.

CLUTCH

1. Inspect:

- Friction plate
Damage/Wear → Replace friction plate as a set.

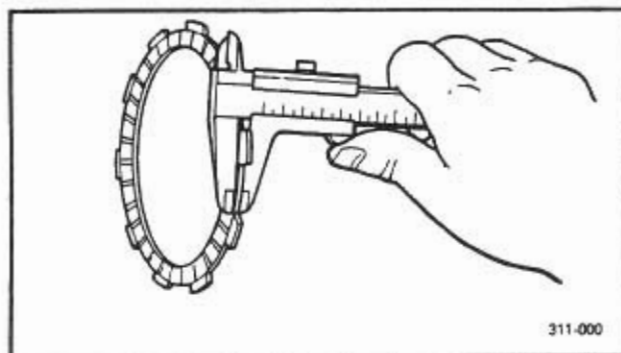

2. Measure:

- Friction plate thickness
Out of specification → Replace friction plate as a set.
Measure at all four points.



Thickness:

2.9 – 3.1 mm (0.114 – 0.122 in)

< Limit: 2.7 mm (0.106 in) >

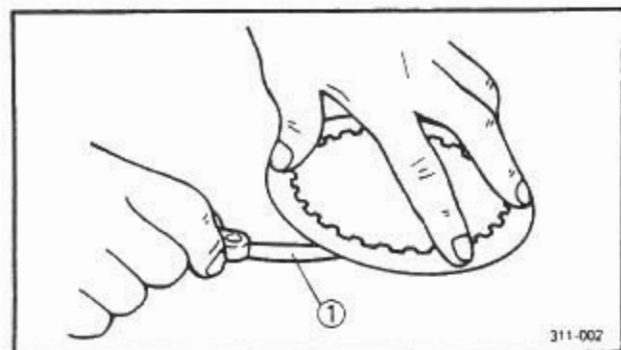

3. Measure:

- Clutch plate warpage
Out of specification → Replace clutch plate as a set.
Use a surface plate and feeler gauge ①.



Warp limit:

Less than 0.05 mm (0.002 in)



4. Inspect:

- Clutch spring
Damage→Replace as a set.

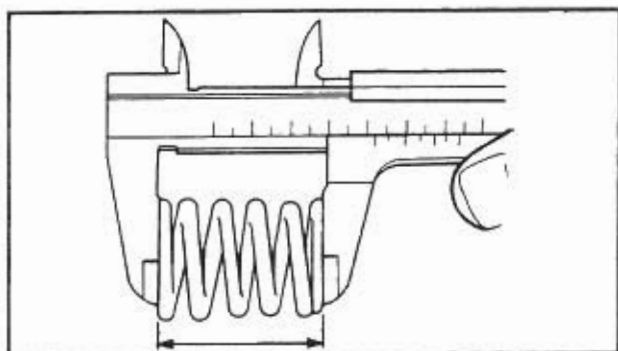

5. Measure:

- Clutch spring free length
Out of specification→Replace spring as a set.



Clutch spring free length:

34.5 mm (1.358 in)

< Limit: 33.5 mm (1.319 in) >

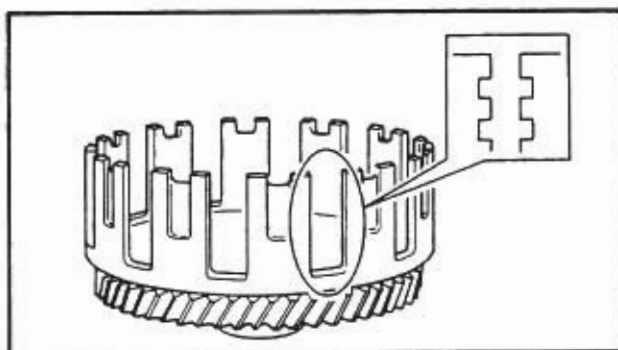

6. Inspect:

- Dogs on the clutch housing
Cracks/Wear/Damage→Deburr or replace.
- Clutch housing bearing
Scoring/Wear/Damage→Replace clutch housing.

NOTE: _____

Scoring on the clutch housing dogs will cause erratic operation.

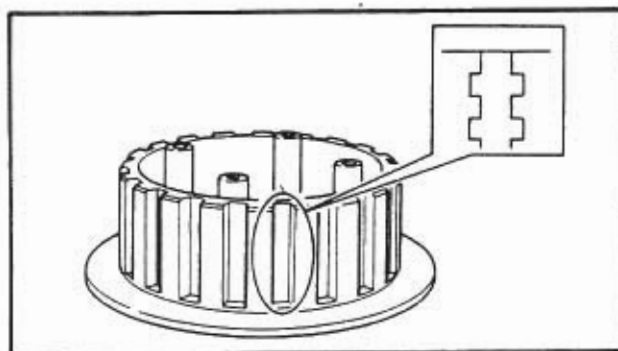

7. Inspect:

- Clutch boss splines
Scoring/Wear/Damage→Replace clutch boss.

NOTE: _____

Scoring on the clutch boss splines will cause erratic operation.

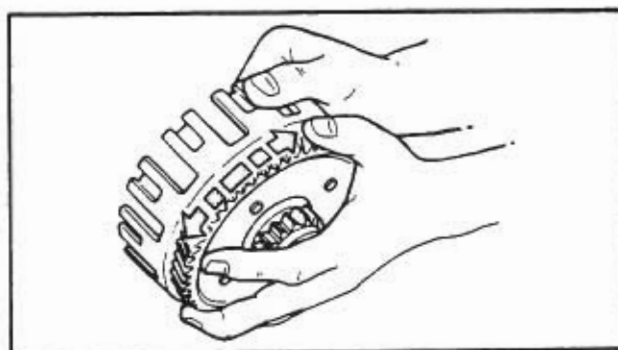

8. Check:

- Circumferential play
Free play exists→Replace.

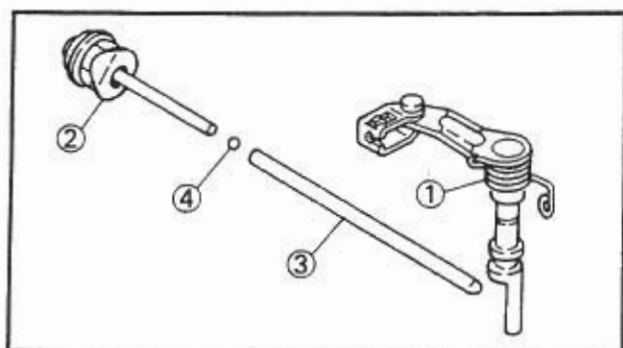

9. Inspect:

- Push lever ①
- Push rod #1 ②
- Push rod #2 ③
- Ball ④

Wear/Crack/Damage → Replace.

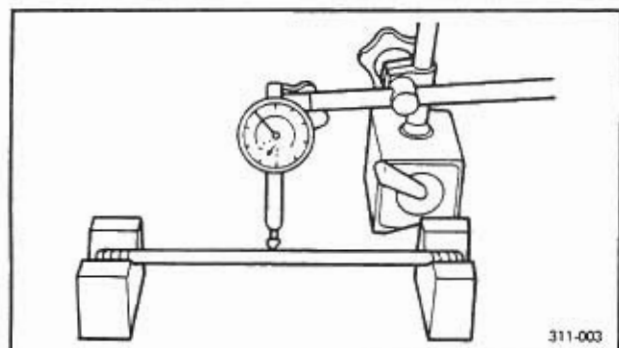

10. Measure:

- Push rod #2 runout
- Out of specification → Replace.
Use a V-Blocks and Dial Gauge.



Runout limit:
0.5 mm (0.02 in)

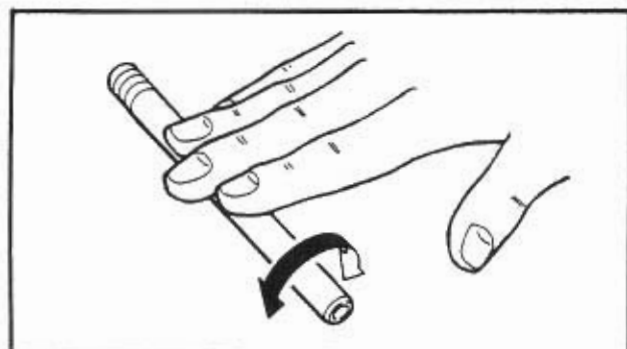

11. Inspect:

- Push rod #1 runout
- Roll the guide bar on a flat surface.
Bends → Replace.

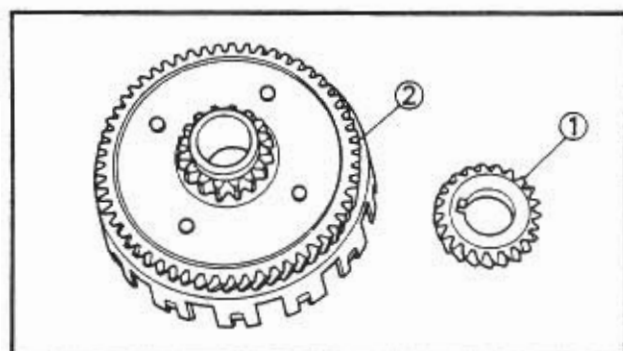

PRIMARY DRIVE GEAR

1. Inspect:

- Primary drive gear teeth ①
 - Primary driven gear teeth ②
- Wear/Damage → Replace both gears.
Excessive noises during operation → Replace both gears.

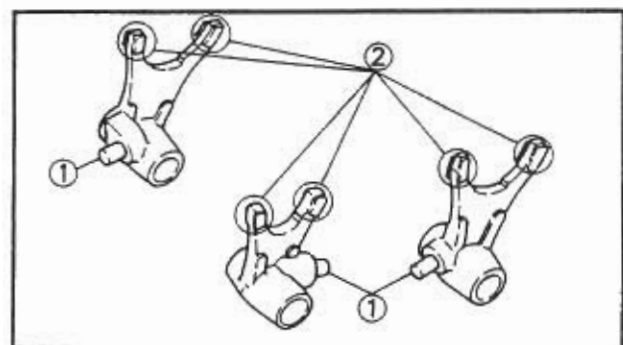

SHIFTER

1. Inspect:

- Shift fork cam follower ①
 - Shift fork pawl ②
- Scoring/Bends/Wear → Replace.

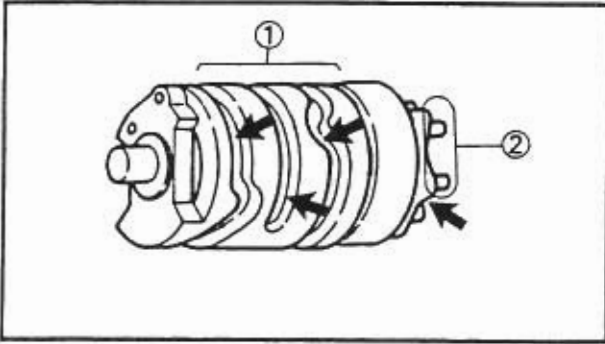

2. Inspect:

- Shift cam groove ①
 - Shift cam segment ②
- Wear/Damage → Replace.

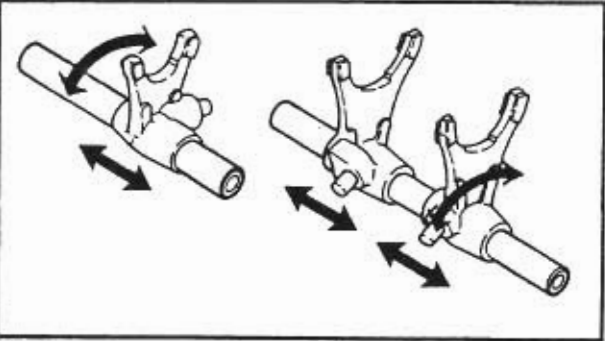

3. Check:

- Shift fork movement
- Unsmooth operation → Replace shift fork and/or guide bar.

4. Inspect:

- Guide bar
- Roll the guide bar on a flat surface.
Bends → Replace.

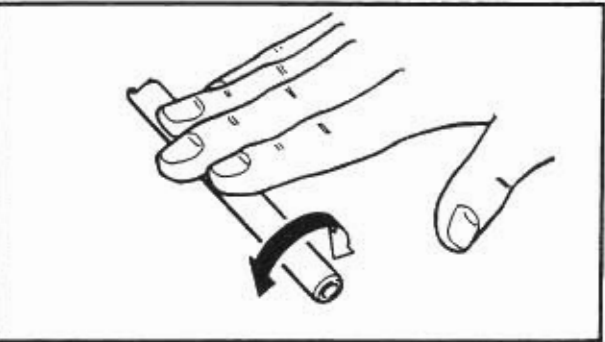
⚠ WARNING

Do not attempt to straighten a bent guide bar.

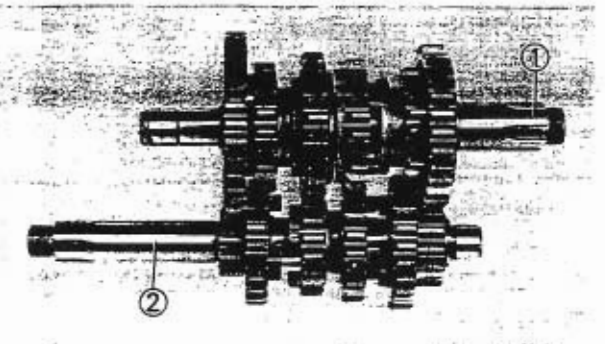

TRANSMISSION

1. Inspect:

- Drive axle ①
 - Main axle ②
- Wear/Damage → Replace.

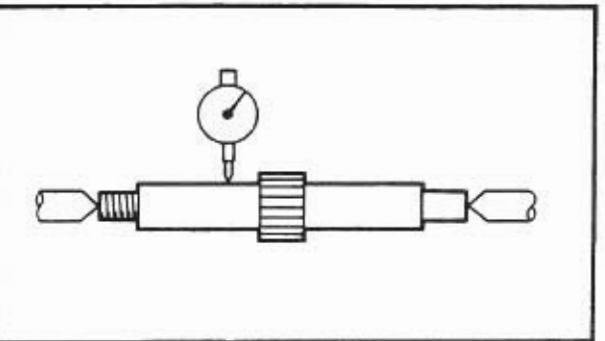

2. Measure:

- Axle runout
- Use centering device and dial gauge.
Out of specification → Replace bent axle.



Runout limit:

0.08 mm (0.003 in)

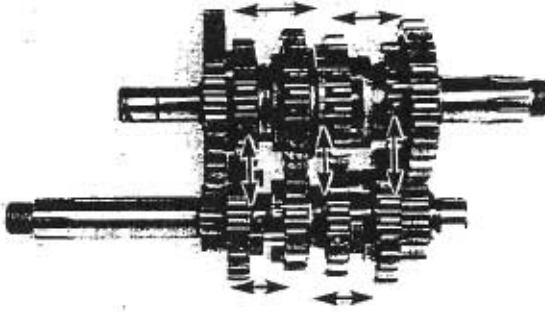

3. Check:

- Proper gear engagement (each gear) (to its counter part)
Incorrect → Reassemble.
- Gear movement
Roughness → Replace.

4. Inspect:

- Criclips
Damage/Looseness/Bends → Replace.

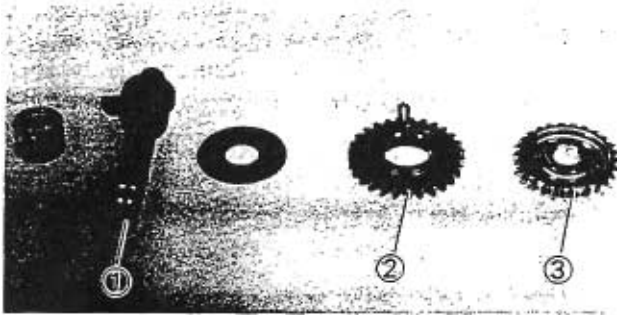

KICK STARTER

1. Inspect:

- Kick axle ①
 - Kick gear teeth ②
 - Kick idle gear teeth ③
- Damage/Wear → Replace both gears.

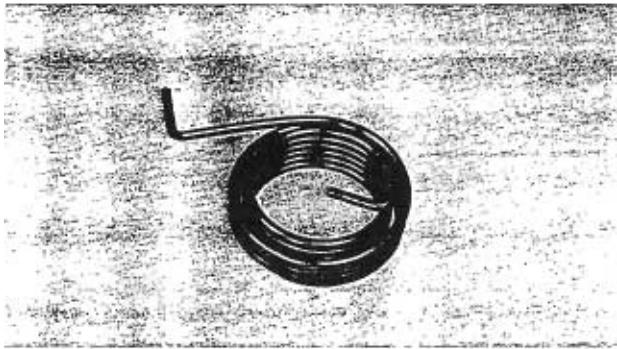

2. Inspect:

- Torsion spring
Damage → Replace.

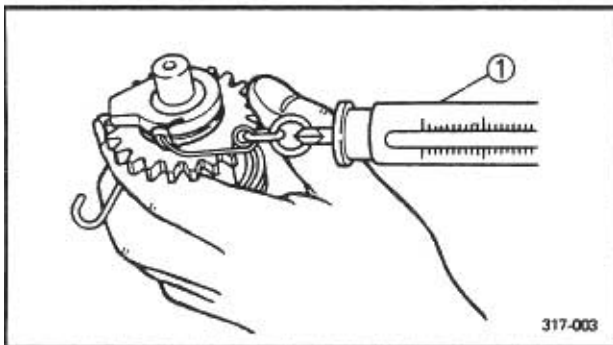

3. Measure:

- Kick clip tension
Out of specification → Replace.
Use a spring balance ①.

Kick clip tension:

0.8 ~ 1.2 kg (1.76 ~ 2.65 lb)

CAUTION:

Do not try to bend the clip.



SHIFT SHAFT

1. Inspect:

- Shift shaft ①
 - Shift lever ②
 - Stopper lever ③
- Damage/Bends/Wear → Replace.

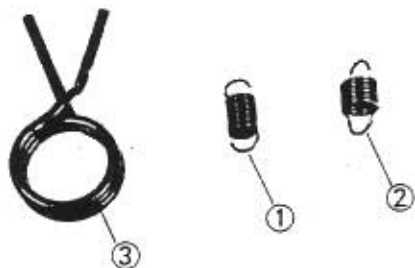

2. Inspect:

- Torsion spring (shift lever) ①
- Torsion spring (stopper lever) ②
- Torsion spring (shift lever) ③

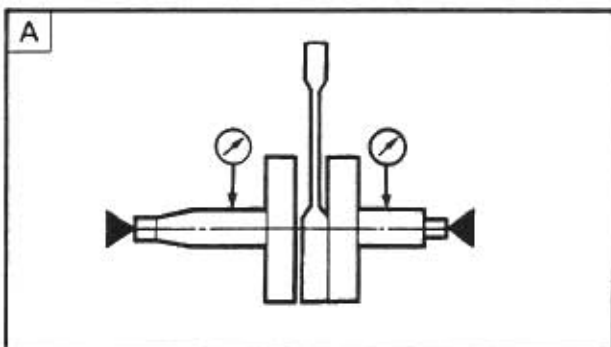

CRANKSHAFT

1. Measure:

- Runout **A**
- Use a centering device and Dial Gauge.
Out of specification → Replace or repair.



Runout limit:
0.02 mm (0.0008 in)

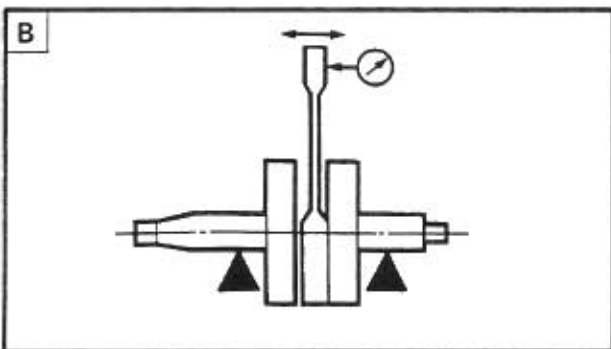

2. Measure:

- Small end free play **B**
- Use a Dial Gauge.
Out of specification → Replace the defective parts.



Small end free play:
0.8 ~ 1.2 mm (0.031 ~ 0.047 in)

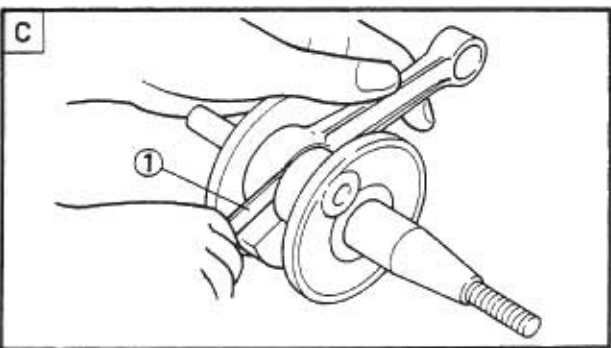

3. Measure:

- Big end side clearance **C**
- Use a Feeler Gauge ①.
Out of specification → Replace the defective parts.



Big end side clearance:
0.20 ~ 0.70 mm (0.008 ~ 0.028 in)
< Limit >:
< 1.0 mm (0.040 in) >

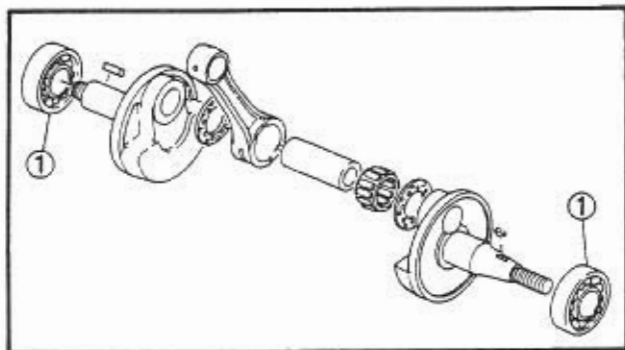
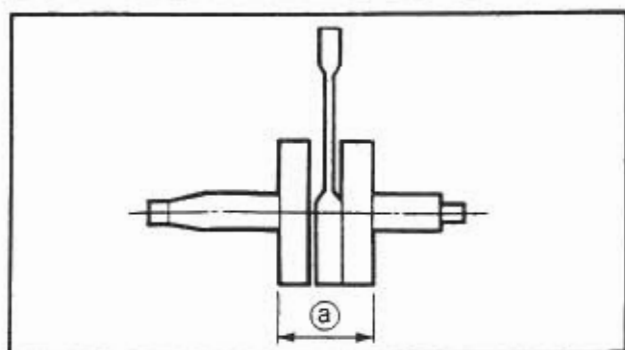

4. Measure:

- Crank width (a)
Out of specification → Replace or repair.



Crank width:
55.90 ~ 55.95 mm
(2.201 ~ 2.203 in)

5. Inspect:

- Crankshaft bearings (1)
Pitting/Damage → Replace.

NOTE:

Lubricate the bearing immediately after examining them to prevent rust.

AUTOLUBE PUMP

Wear or an internal malfunction may cause pump output to vary from the factory setting.

This situation is, however, extremely rare. If improper output is suspected, inspect the following:

1. Inspect:

- Delivery line
Obstructions → Blow out.
- Pump body seal/Crankcase cover seal
Wear/Damage → Replace.
- Check ball/Spring
Miss/Improper → Repair.

2. Inspect:

- Allowing air
Air exists → Air bleed.

3. Check:

- Pump output
Out of specification → Adjust.

Minimum output/200 stroke:

0.38 ~ 0.44 cm³ (0.014 ~ 0.016 Imp oz,
0.013 ~ 0.015 US oz)

Maximum output/200 stroke:

2.33 ~ 2.58 cm³ (0.083 ~ 0.092 Imp oz,
0.075 ~ 0.083 US oz)

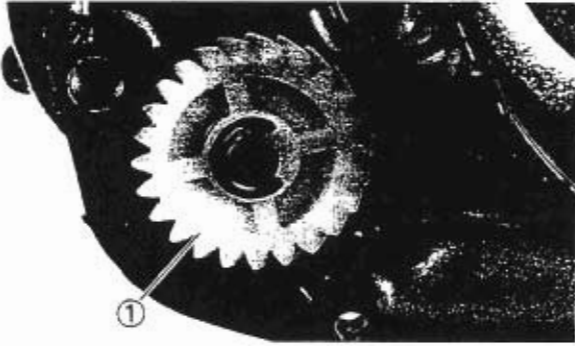

4. Inspect:

- Drive gear (Autolube pump) ①
Cracks/Wear/Damage → Replace.
- Warm shaft
Wear/Damage → Replace.

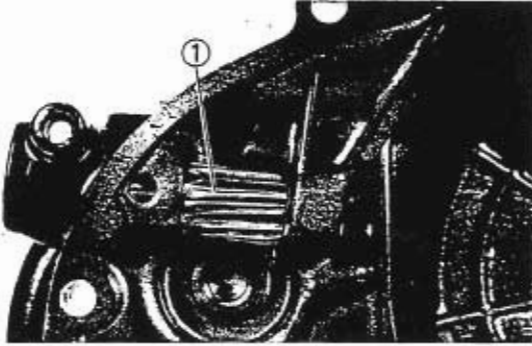
**TACHOMETER GEAR**

1. Inspect:

- Driven gear ①
Damage/Wear → Replace.

2. Check:

- Gear movement
Unsmooth operation → Replace.

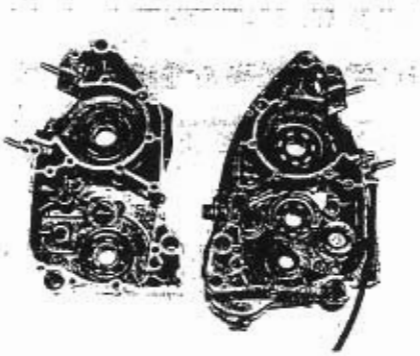
**CRANKCASE**

1. Thoroughly wash the case halves in mild solvent.
2. Clean all the gasket mating surfaces and crankcase mating surfaces thoroughly.
3. Inspect:
 - Crankcase
Cracks/Damage → Replace.
 - Oil delivery passages
Clog → Blow out with compressed air.



ENGINE ASSEMBLY AND ADJUSTMENT

⚠ WARNING

For engine reassembly, replace the following parts with new ones.

- O-ring
- Gasket
- Oil seal
- Lock washer
- Circlip

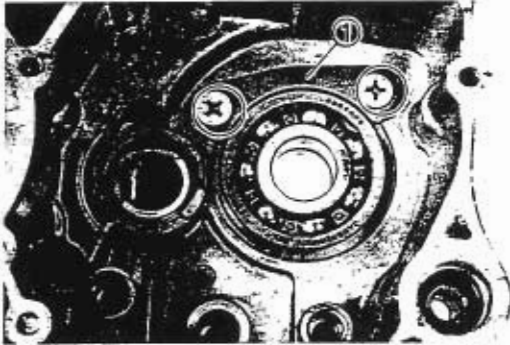

CRANKCASE (LEFT)

1. Install:
 - Bearing retainer ①



Screw (bearing retainer):
10 Nm (1.0 m·kg, 7.2 ft·lb)
LOCTITE®

CRANKSHAFT

CAUTION:

To protect the crankshaft against scratches or to facilitate the operation of the installation, apply the grease to the oil seal lips, and apply the engine oil to each bearing.

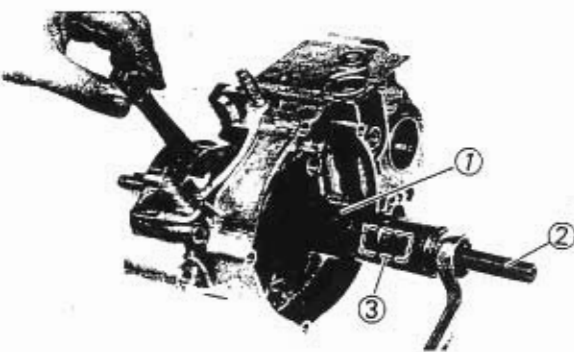

1. Install:
 - Crankshaft (to crankcase left)

NOTE:

- Attach the crankshaft installing tool to install the crankshaft.
- Hold the connecting rod at top dead center with one hand while turning the nut of the installing tool with the other. Operate the installing tool until the crankshaft bottoms against the bearing.



Crankshaft installing tool:
P/N. 90890-01274 ①
P/N. 90890-01275 ②
P/N. 90890-01278 ③



TRANSMISSION

- | | | |
|-----------------------|------------------|------------------|
| ① Main axle | ⑩ 2nd wheel gear | ⑲ Circlip |
| ② 2nd pinion gear | ⑪ 3rd wheel gear | ⑳ Bearing |
| ③ 3rd/4th pinion gear | ⑫ 4th wheel gear | ㉑ Bearing |
| ④ 5th pinion gear | ⑬ 5th wheel gear | ㉒ Bearing |
| ⑤ 6th pinion gear | ⑭ 6th wheel gear | ㉓ Bearing |
| ⑥ Plain washer | ⑮ Plain washer | ㉔ Oil seal |
| ⑦ Circlip | ⑯ Washer | ㉕ Collar |
| ⑧ Drive axle | ⑰ Circlip | ㉖ Drive sprocket |
| ⑨ 1st wheel gear | ⑱ Plain washer | ㉗ Lock washer |

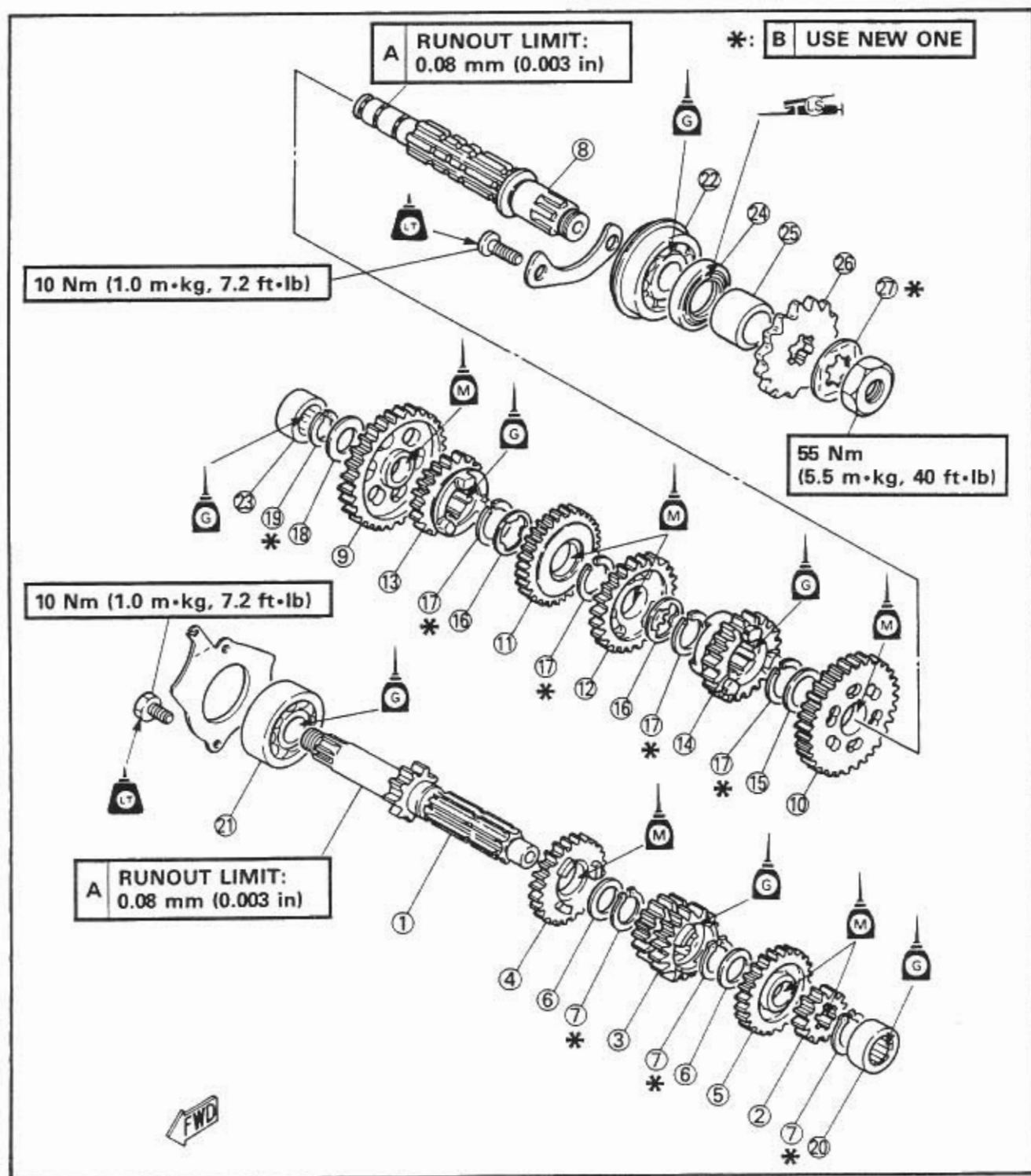



SHIFTER

- ① Shift cam assembly
- ② Segment
- ③ Side plate
- ④ Circlip
- ⑤ Dowel pin
- ⑥ Shift fork #1
- ⑦ Shift fork #2
- ⑧ Guide bar #1
- ⑨ Guide bar #2

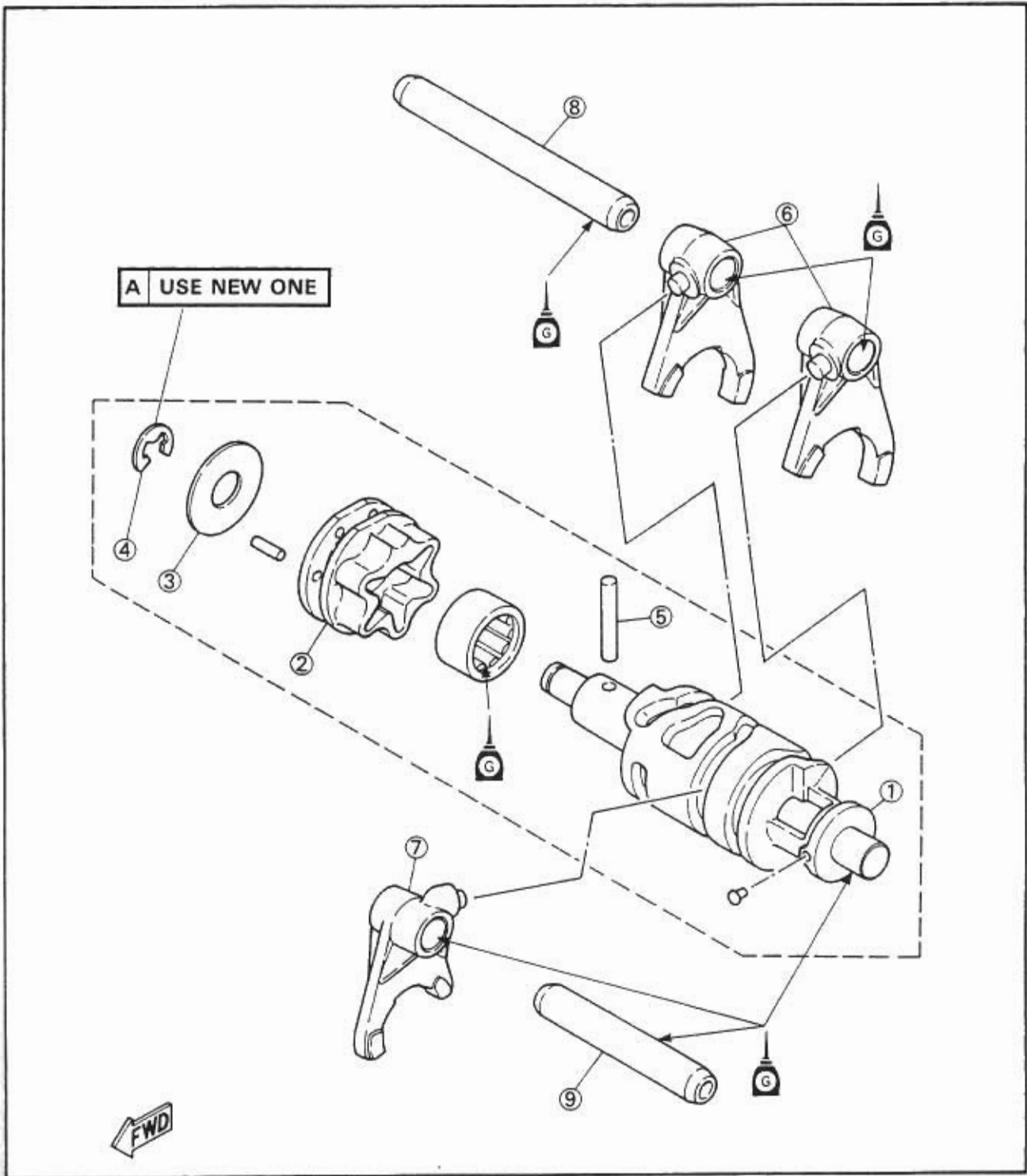

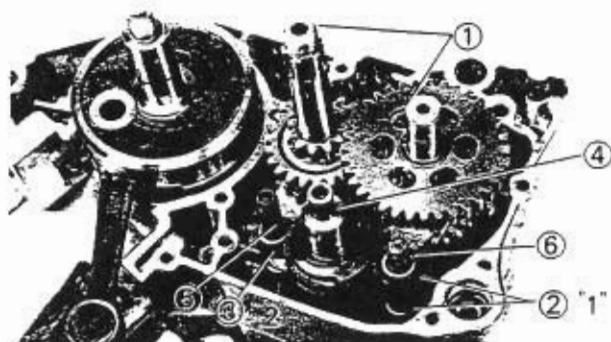

TRANSMISSION AND SHIFTER

1. Install:

- Transmission ①
- Shift fork #1 ②
- Shift fork #2 ③
- Shift cam ④
- Guide bar (shorter) ⑤
- Guide bar (longer) ⑥

NOTE:

Install the shift fork with the embossed number should face left side.

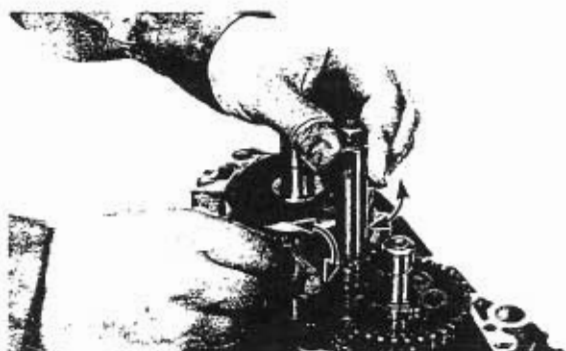

2. Lubricate:

- Transmission component parts



SAE 10W30 type SE motor oil

3. Check:

- Shifter operation
- Unsmooth operation → Repair.

NOTE:

- Oil each gear and bearing thoroughly.
- Before assembling the crankcase, be sure that the transmission is in neutral and that the gears turn freely.

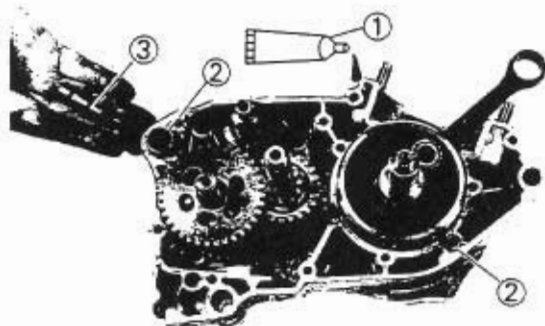

CRANKCASE (RIGHT)

1. Apply:

- Yamaha bond No. 1215 ①
(to mating surface of both crankcase halves)



Yamaha bond No. 1215:
P/N. 90890-85505

2. Install:

- Dowel pins ②
- Damper collar ③

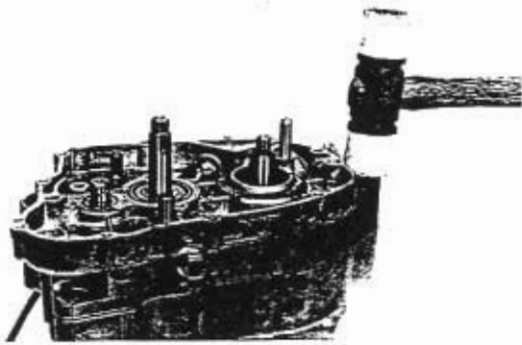

3. Install:
 - Crankcase (right)

Installation steps:

- Apply the lithium soap base grease to the oil seal lips.
- Fit the right crankcase onto the left case.
Tap lightly on the case with a soft hammer.

NOTE: _____

Turn the shift cam to the position shown in the figure so that it does not contact the crankcase when installing the crankcase.

- Tighten the bolts (crankcase).

CAUTION: _____

Before installing and torquing the bolts (crankcase) be sure to check whether the transmission is functioning properly by manually rotating the shift cam either way.

NOTE: _____

Tightening the screws (crankcase) in stage, using a crisscross pattern.

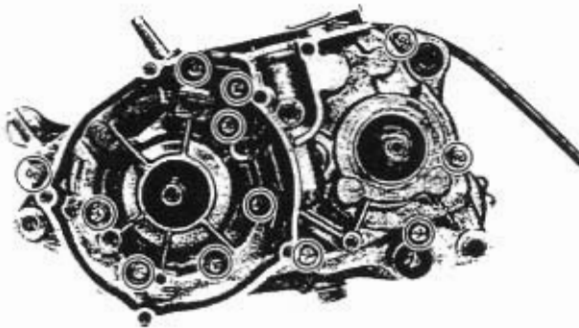

| | |
|--|--|
| | <p>Bolt (crankcase): 8 Nm (0.8 m·kg, 5.8 ft·lb)</p> |
|--|--|

4. Apply:
 - 2-stroke oil
(to crank pin, bearing and oil delivery hole)

5. Check:
 - Crankcase and transmission operation
Unsmooth operation → Repair.

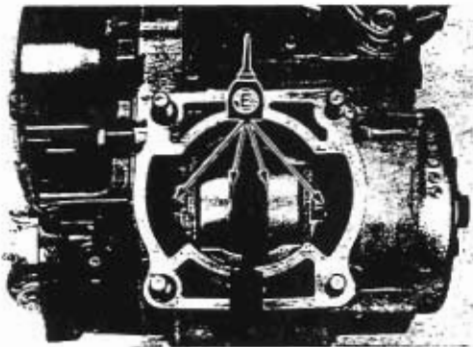



MAGNETO ROTOR

- ① Stator assembly
- ② Rotor
- ③ Washer
- ④ Spring washer
- ⑤ Nut

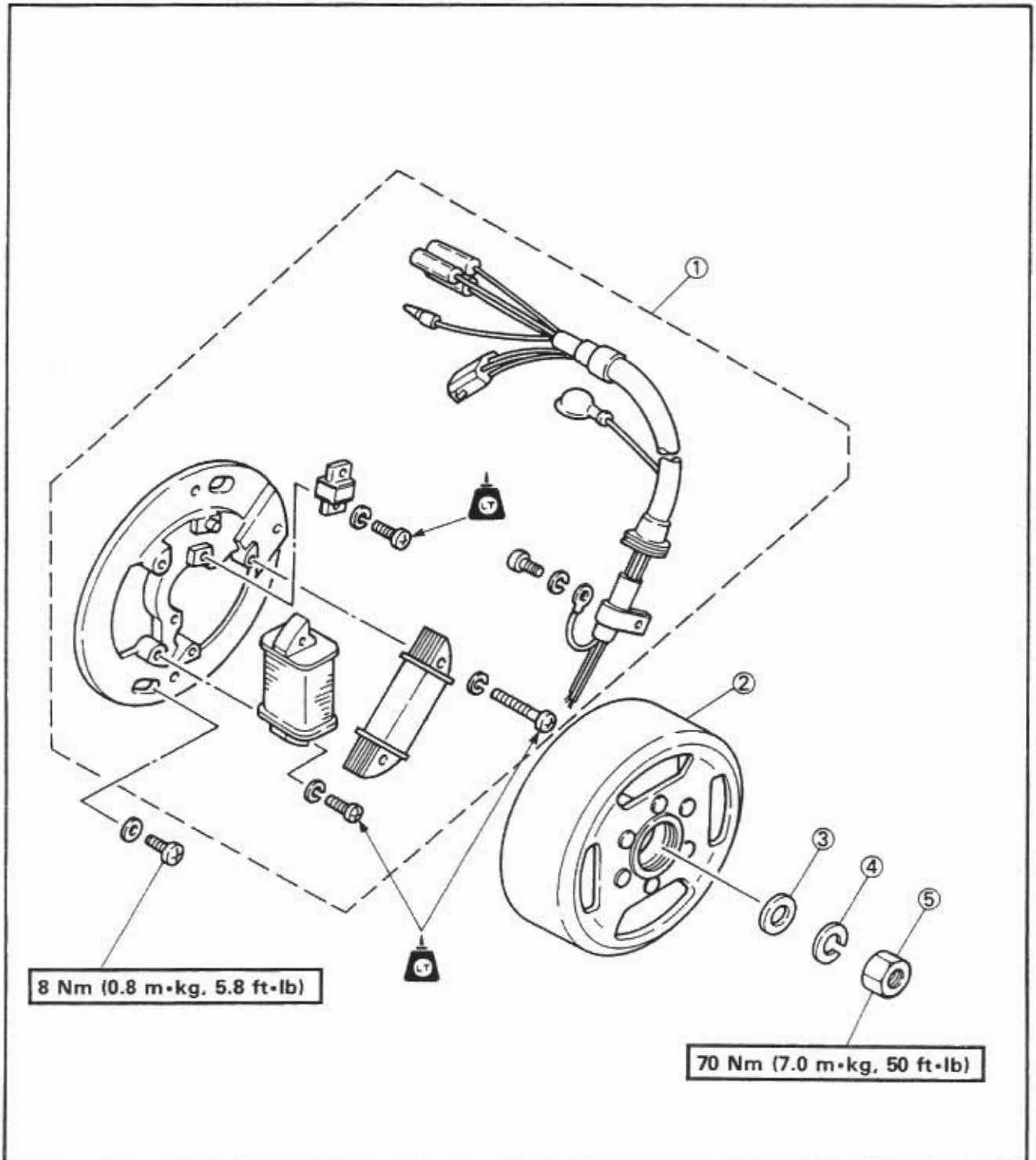

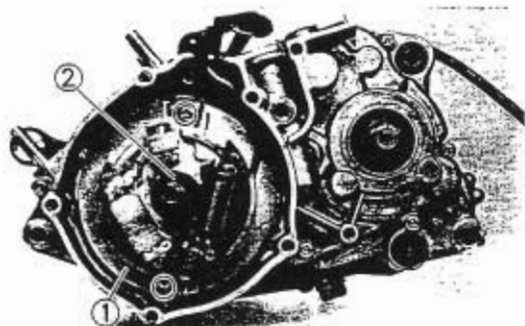
**CDI MAGNETO**

1. Install:

- Stator ①
- Woodruff key ②



Screw (stator):

8 Nm (0.8 m•kg, 5.8 ft•lb)

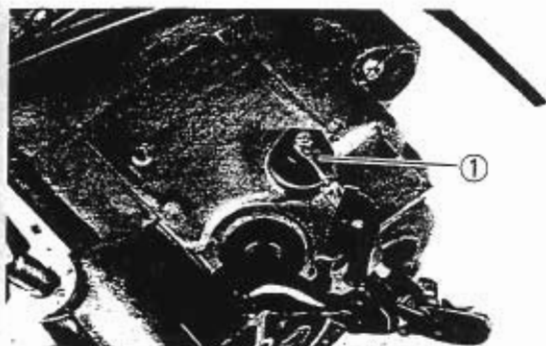

2. Connect:

- Neutral switch lead ①

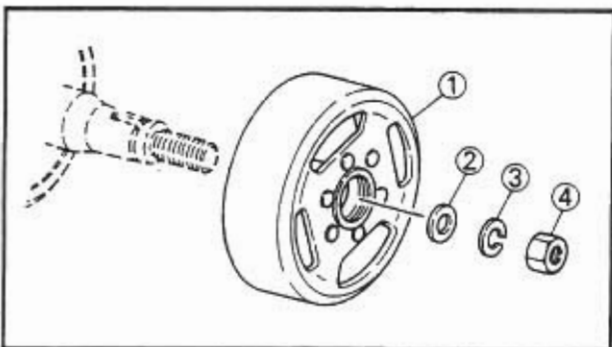

3. Install:

- Magneto rotor ①
- Plain washer ②
- Spring washer ③
- Nut (rotor) ④

NOTE:

- Clean the tapered portion of the crankshaft and magneto rotor.
- When installing the magneto rotor, make sure the woodruff key is properly seated in the key way of the crankshaft.

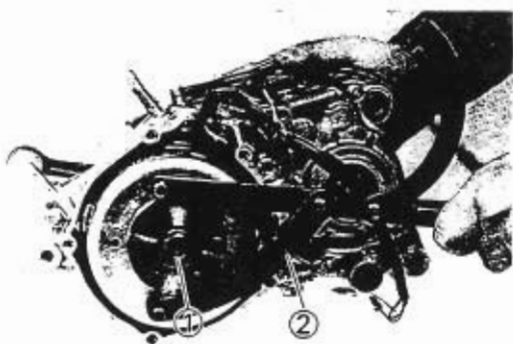

4. Tighten:

- Nut (rotor) ①

NOTE:

Hold the rotor by the rotor holder ② to tighten the nut ①.



Universal rotor holder:

P/N. 90890-01235



Nut (magneto):

70 Nm (7 m•kg, 50 ft•lb)



SHIFT SHAFT

- | | |
|---------------------|-----------------|
| ① Shift lever assy. | ⑩ Screw |
| ② Spring | ⑪ Nut |
| ③ Spring | ⑫ Lock washer |
| ④ Circlip | ⑬ Shaft |
| ⑤ Shift shaft | ⑭ Plain washer |
| ⑥ Roller | ⑮ Circlip |
| ⑦ Circlip | ⑯ Spring |
| ⑧ Shift pedal | ⑰ Stopper lever |
| ⑨ Oil seal | ⑱ Bolt |

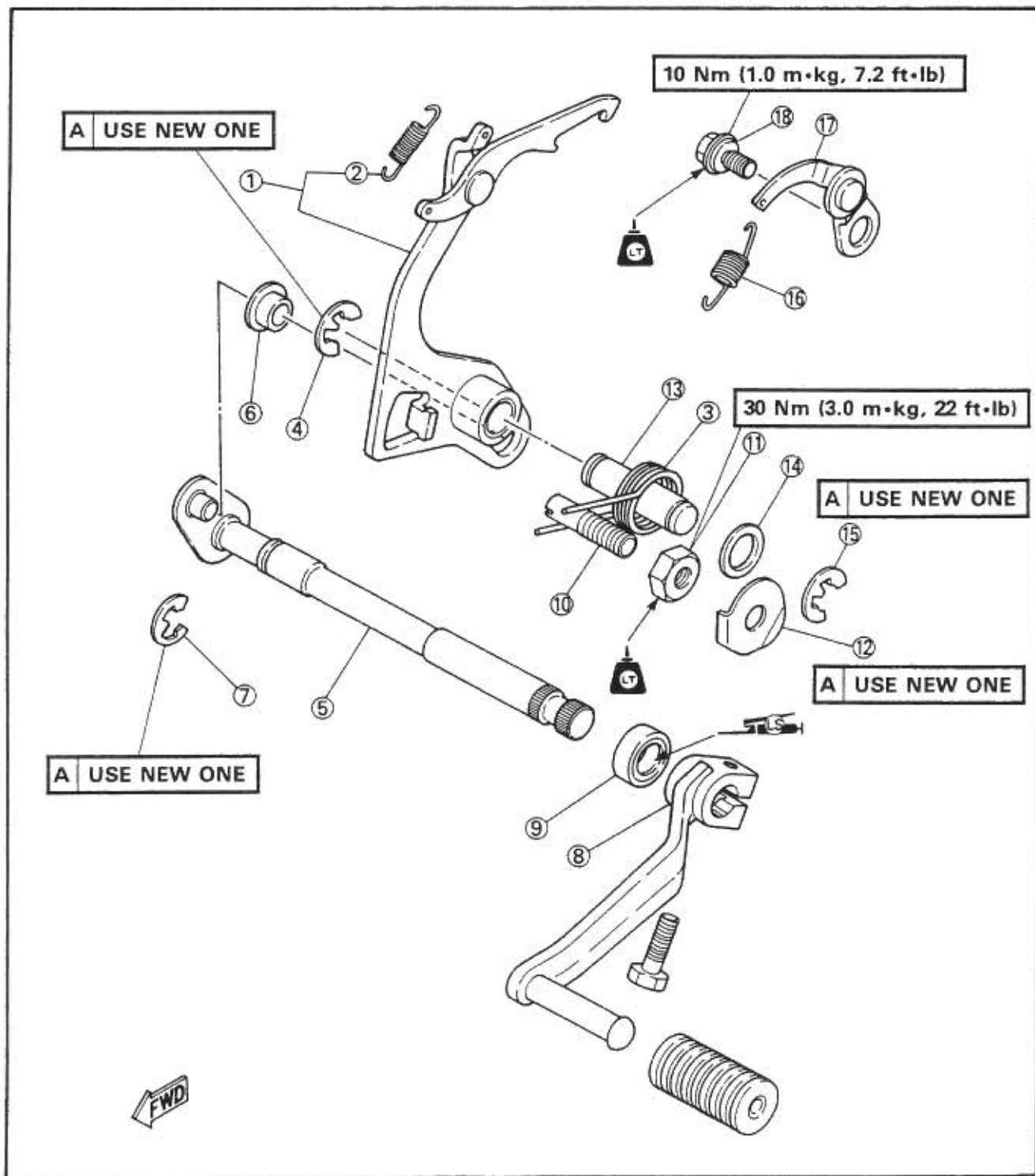

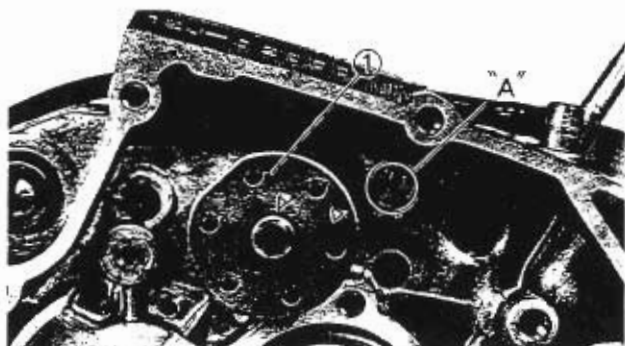
**SHIFT SHAFT**

1. Install:
 - Segment ①

NOTE: _____
Align the match marks with "A" boss as shown.

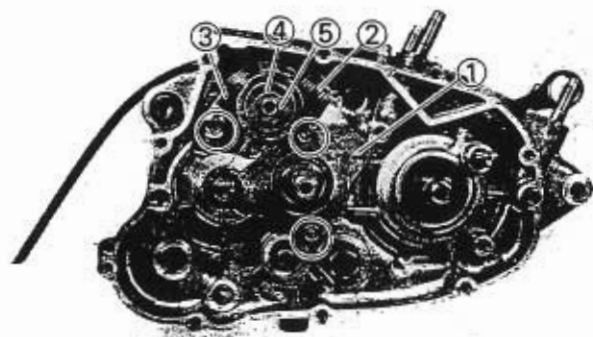

2. Install:
 - Plate cover ①
 - Spring ②
 - Stopper lever ③
 - Washer ④
 - Circlip ⑤



Bolt (stopper plate/stopper lever): ①, ③
10 Nm (1.0 m•kg, 7.2 ft•lb)
LOCTITE®

NOTE: _____
Mesh the stopper lever ③ with the shift cam stopper.

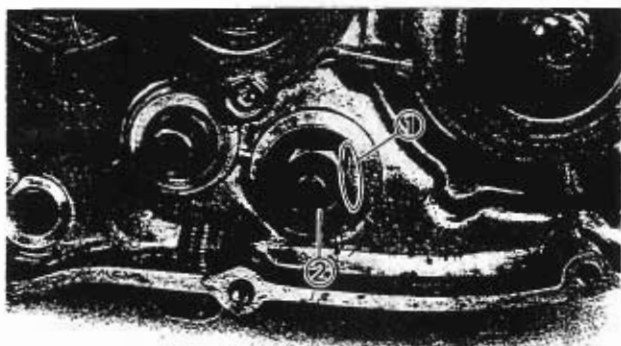

3. Install:
 - Lock washer ①
 - Nut ②

⚠ WARNING

Always use a new lock washer.

NOTE: _____
Bend the lock washer tab along the nut flat.

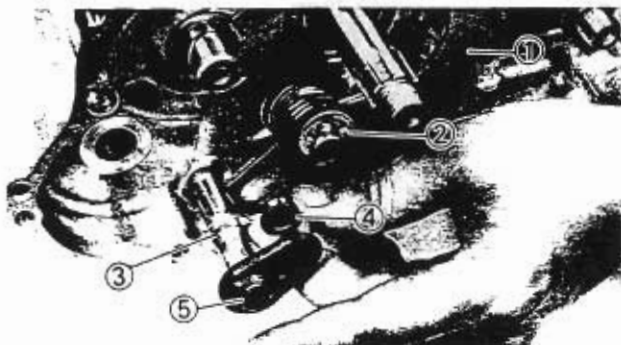

4. Install:
 - Shift lever ①
 - Circlip ②
 - Circlip ③
 - Roller ④
 - Shift shaft ⑤

NOTE: _____
• Insert the stopper between spring ends.
• Apply the grease to the oil seal lip.



KICK AXLE

- ① Kick crank
- ② Oil seal
- ③ Spring guide
- ④ Kick spring
- ⑤ Washer
- ⑥ Kick gear
- ⑦ Clip
- ⑧ Kick axle
- ⑨ Circlip
- ⑩ Washer
- ⑪ Kick idle gear

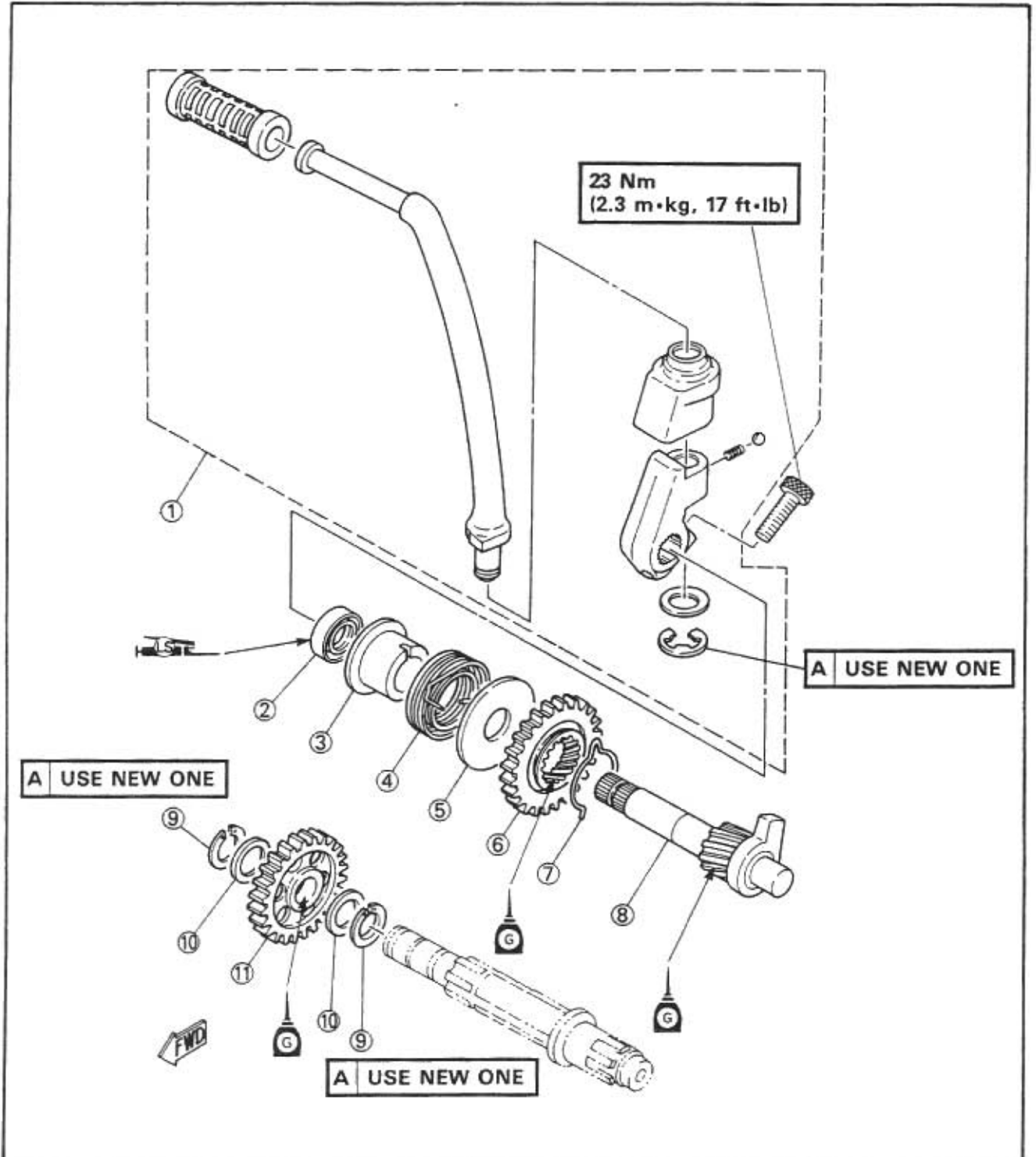

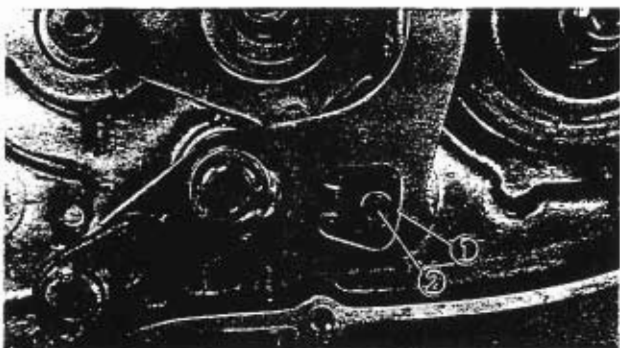
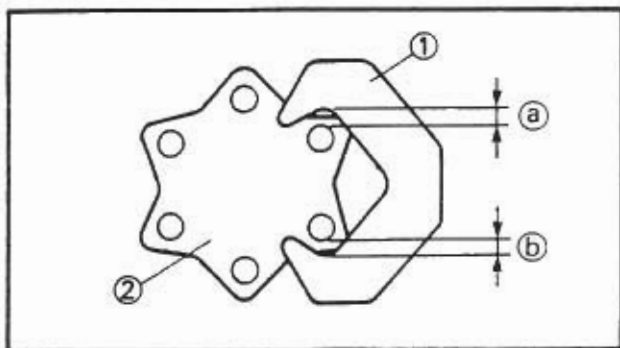

5. Check:

- Shift lever position
- Gap (A) and (B) are not equal → Adjust.

Adjustment steps:

- Straighten lock washer tab.
- Loosen the locknut (1).
- Turn adjuster (2) in or out until gap (A) and (B) are equal.
- Tighten locknut.

| | |
|---|--|
|  | <p>Nut: 30 Nm (3.0 m•kg, 22 ft•lb) LOCTITE®</p> |
|---|--|

- Bend lock washer tab.

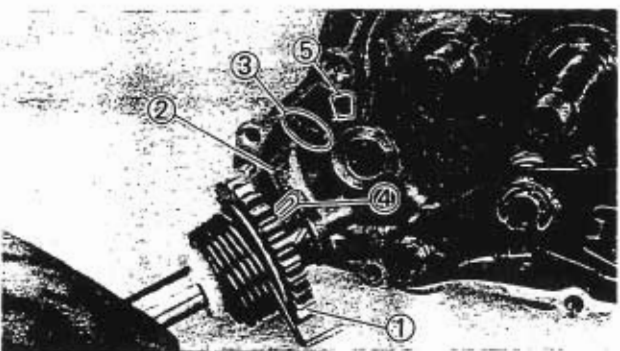

KICK AXLE AND KICK IDLE GEAR

1. Install:

- Kick axle assembly (1)

NOTE:

- Make sure that the kick stopper (2) is stopped at the projection (3) of the crankcase.
- Make sure that the kick clip (4) is engaged with the crankcase hole (5).

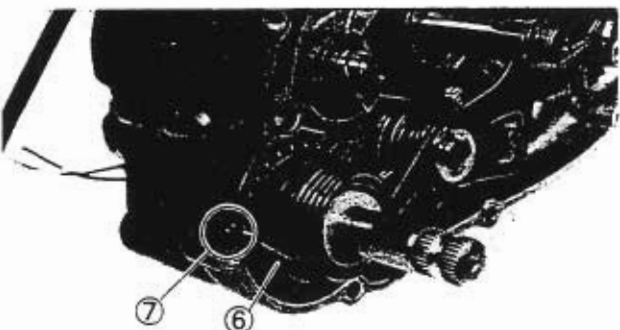

2. Set the kick spring (6) to the spring hook (7).

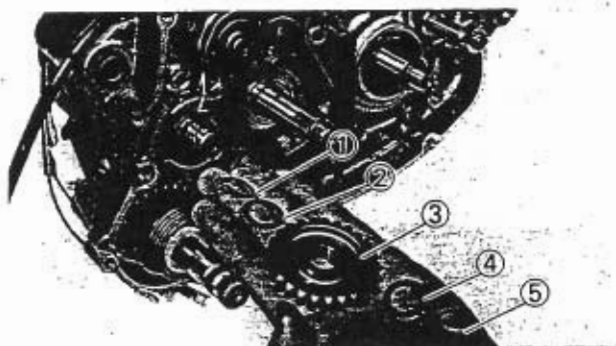

3. Install:
- Circlip ①
 - Washer ②
 - Kick idle gear ③
 - Washer ④
 - Circlip ⑤

4. Check:
- Kick axle operation
Use the kick crank.
Unsmooth operation → Repair.

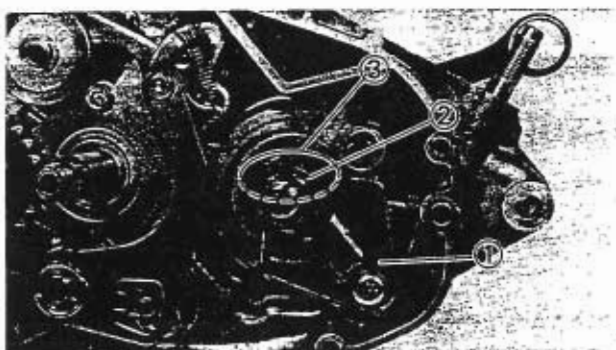

PRIMARY DRIVE GEAR

1. Install:
- Oil seal retainer ①
 - Spacer collar ②



Oil seal retainer:
10 Nm (1.0 m·kg, 7.2 ft·lb)

NOTE: _____
Before installing the spacer collar ②, grease the oil seal lip ③.

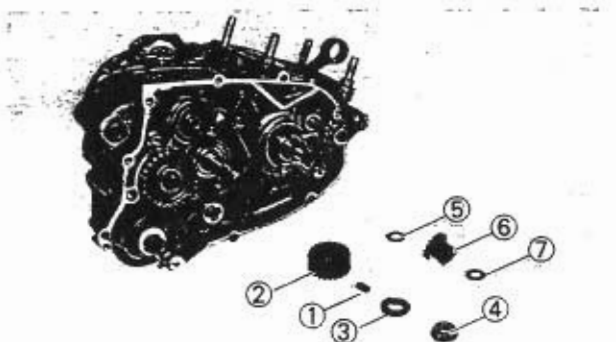

2. Install:
- Straight key ①
 - Drive gear ②
 - Spring washer ③
 - Nut ④
 - Washer ⑤
 - Drive gear (tachometer cable) ⑥
 - Washer ⑦

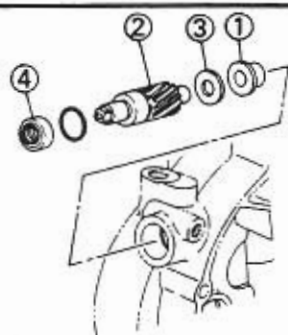

3. Install:

- Bush ①
- Drive gear (tachometer cable) ②
- Washer ③
- Oil seal ④

CLUTCH

1. Install:

- Thrust plate ①
- Spacer ②
- Clutch housing ③
- Thrust washer ④
- Clutch boss ⑤
- Lock washer ⑥
- Nut (clutch boss) ⑦

⚠ WARNING

Always use a new lock washer.

2. Tighten:

- Nut (clutch boss) ⑦



Nut (clutch boss):
40 Nm (4.0 m·kg, 29 ft·lb)

NOTE:

- Tighten the nut (clutch boss) ⑦ while holding the clutch boss with the universal clutch holder ②.
- Bend the lock washer tab along the nut flat.



Universal clutch holder:
P/N. 90890-04086

3. Tighten:

- Nut (primary drive gear) ①

NOTE:

Place a folded fragment of aluminum ② between the teeth of the drive gear ③ and driven gear ④ to lock them.



Nut (primary drive gear):
60 Nm (6.0 m·kg, 43 ft·lb)

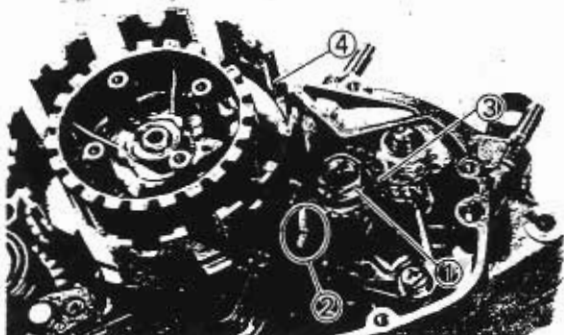
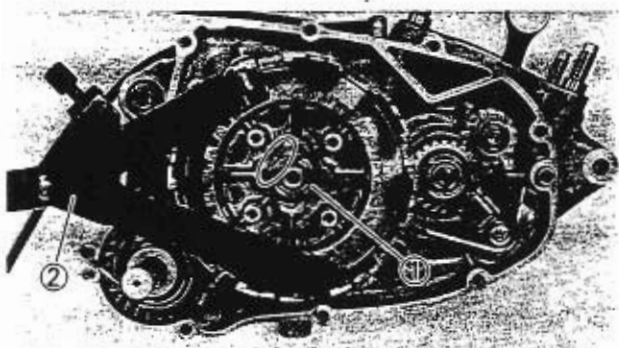
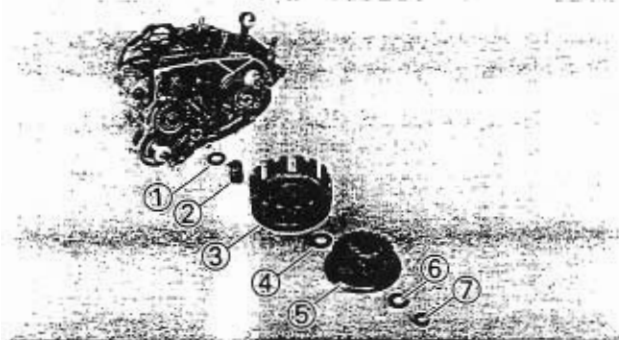



CLUTCH AND PRIMARY DRIVE GEAR

- | | |
|----------------------|----------------------|
| ① Clutch spring | ⑪ Push rod # 1 |
| ② Pressure plate # 1 | ⑫ Ball |
| ③ Pressure plate # 2 | ⑬ Push rod # 2 |
| ④ Clutch plate | ⑭ Push lever axle |
| ⑤ Friction plate | ⑮ Bolt |
| ⑥ Clutch boss | ⑯ Spring |
| ⑦ Thrust washer | ⑰ Oil seal |
| ⑧ Clutch housing | ⑱ Primary drive gear |
| ⑨ Thrust plate | ⑲ Spring washer |
| ⑩ Spacer | ⑳ Nut |

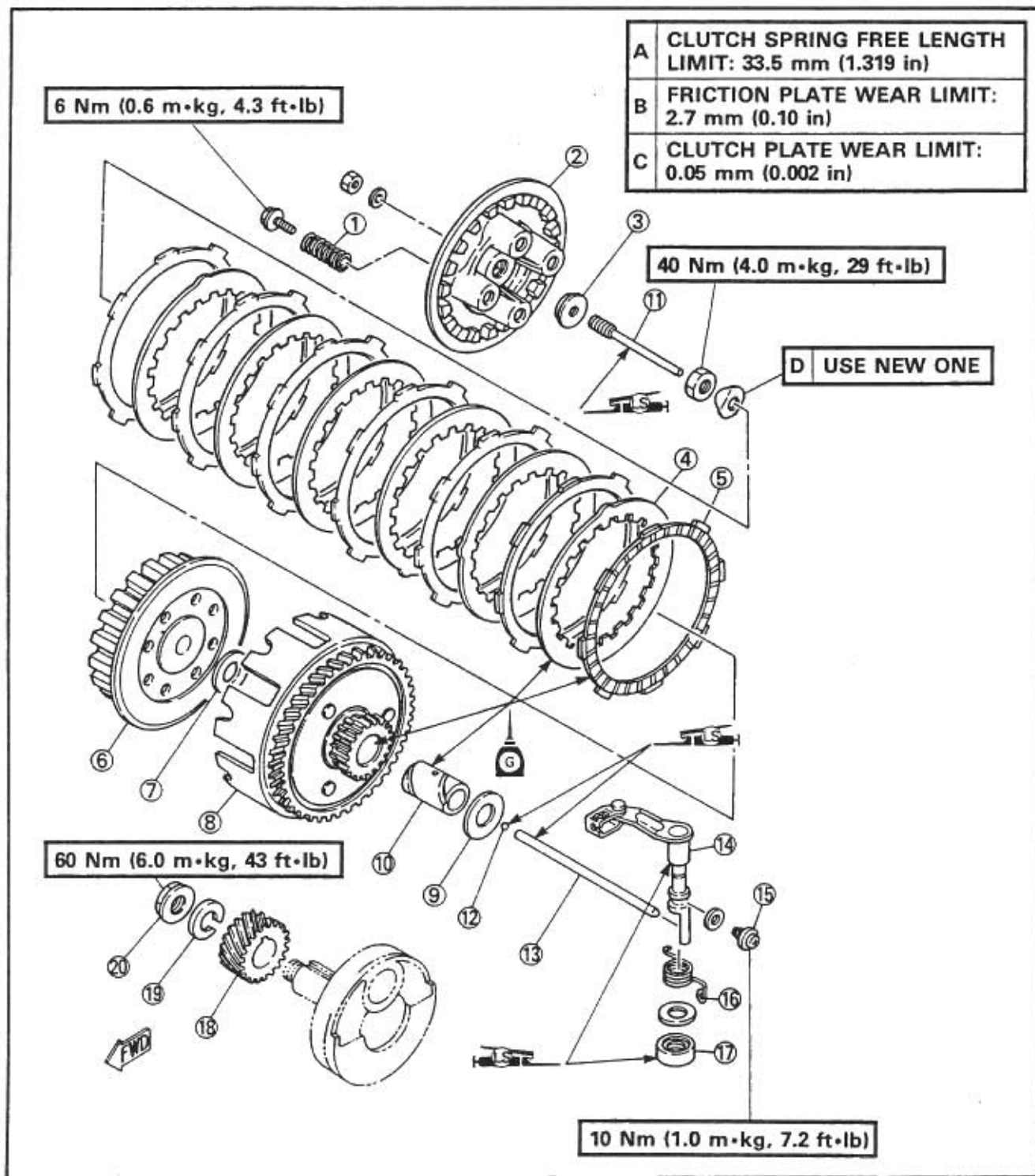

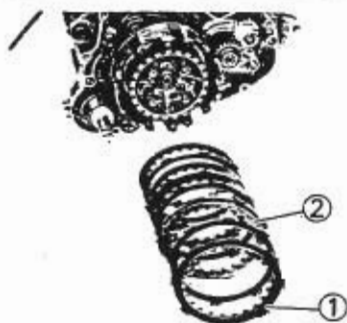

4. Install:
- Friction plates ①
 - Clutch plates ②

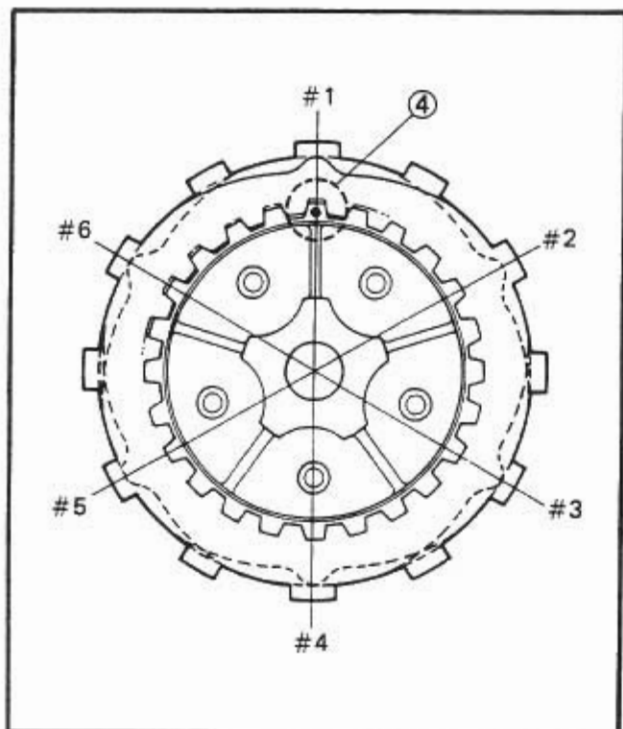

Installation steps:

- Install the friction plate onto the clutch boss.
 - Install the clutch plate so as to locate the projection ④ at #1.
 - Install the friction plate with the larger inside diameter onto the clutch boss.
 - Install the clutch dumper onto the clutch plate.
 - Next install the remaining clutch plates and friction plates alternately on the clutch boss.
 - Be sure to install a clutch plate with projection offset approximately 60° from previous plate projection.
- Continue this procedure in a clockwise direction until all clutch plates are installed.

NOTE: _____

Before installing a friction and clutch plates, apply sufficient coating of transmission oil to each plate.



5. Install:
- Washer ①
 - Return spring ②
 - Push lever ③
 - Gasket ④
 - Bolt ⑤ (stopper)

| | |
|--|---|
| | <p>Bolt (stopper): 10 Nm (1.0 m•kg, 7.2 ft•lb)</p> |
|--|---|

6. Set the return spring ② to the spring hook ⑥.

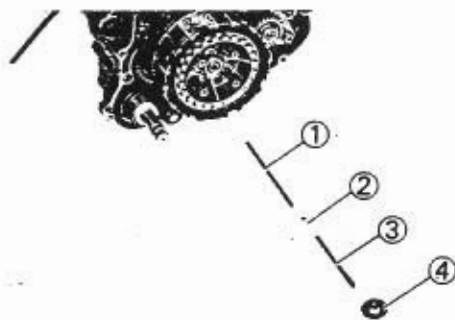

7. Install:

- Push rod #2 (1)
- Ball (2)
- Push rod #1 (3)
- Pressure plate #2 (4)

NOTE:

Apply the lithium soap base grease to the push rod #2 and ball.

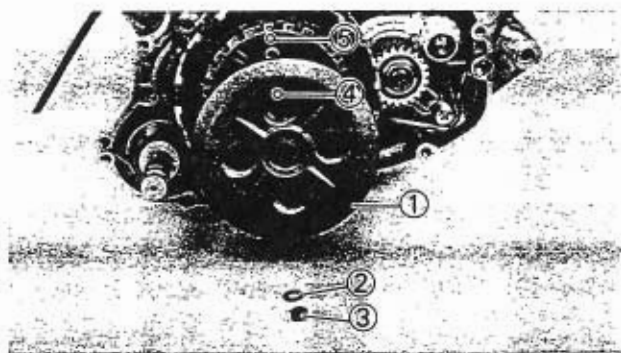

8. Install:

- Pressure plate #1 (1)
- Washer (2)
- Nut (push rod) (3)

NOTE:

Align the punched mark (4) on the clutch boss with the punched mark (5) on the clutch pressure plate #1.

9. Install:

- Clutch spring (1)
- Bolts (clutch spring) (2)



Bolt (clutch spring):
6 Nm (0.6 m•kg, 4.3 ft•lb)

10. Adjust:

- Clutch mechanism free play
Refer to the "CLUTCH MECHANISM ADJUSTMENT" section in the CHAPTER 3.

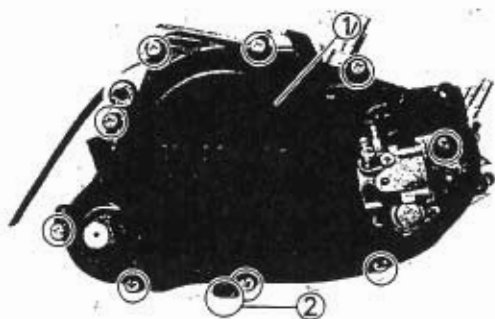

11. Install:

- Gasket (crankcase cover)
- Dowel pins
- Crankcase cover (right) (1)
- Drain plug (transmission oil) (2)

NOTE:

Tighten the screws (crankcase cover) in stage, using a crisscross pattern.

⚠ WARNING

Always use a new gasket.



Screw (crankcase cover):
10 Nm (1.0 m•kg, 7.2 ft•lb)
Drain plug (transmission oil):
15 Nm (1.5 m•kg, 11 ft•lb)

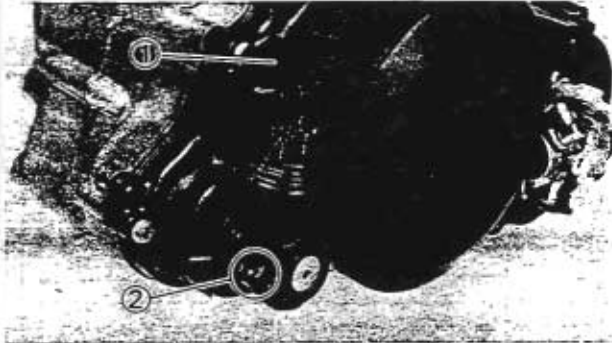

12. Install:

- Oil level gauge ①
- Kick crank ②



Bolt (kick crank):
23 Nm (2.3 m•kg, 17 ft•lb)

CYLINDER AND PISTON

1. Install:

- Piston rings

CAUTION:

- Make sure ring ends are properly fitted around ring locating pins ① in piston grooves.
- Be sure to check the manufacturer's marks or numbers stamped on the rings are on the top side of the rings.

2. Install:

- Bearing ①
- Piston ②
- Piston pin ③
- Piston pin clips ④

NOTE:

- Apply 2-stroke engine oil to the crankshaft, piston pin, bearing, piston ring groove and piston skirt areas.
- The arrow on the piston must point to the front of the engine.
- Before installing the piston pin clip, cover the crankcase with a clean towel or rag so you will not accidentally drop the pin clip and material into the crankcase.

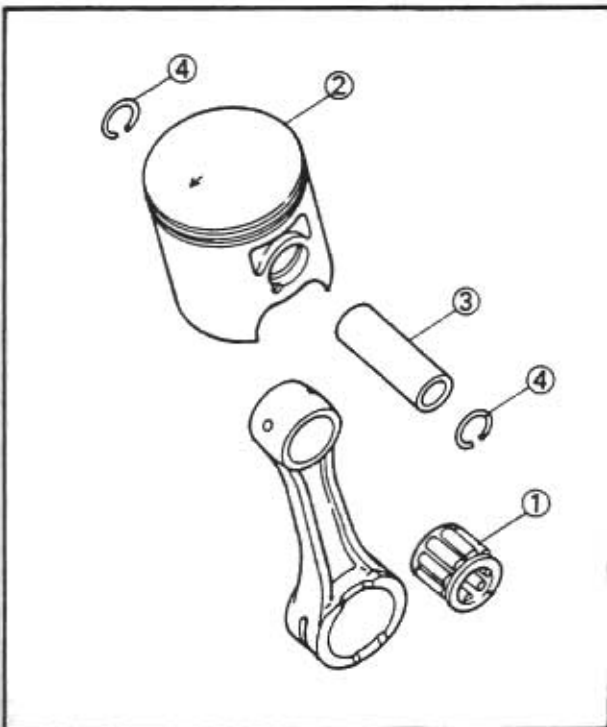
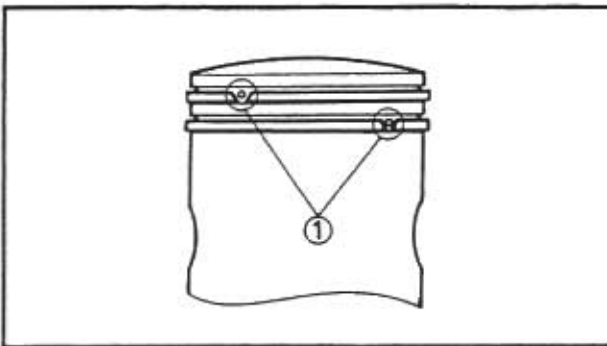



CYLINDER HEAD AND CYLINDER

- ① Spark plug
- ② Cylinder head
- ③ Cylinder head gasket
- ④ Cylinder
- ⑤ Cylinder gasket

| | |
|---|---|
| A | SPARK PLUG: |
| B | MANUFACTURER: NGK |
| C | TYPE: B8ES |
| D | PLUG GAP: 0.7-0.8 mm (0.028-0.032 in) |
| E | CYLINDER HEAD WARPAGE LIMIT: 0.05 mm (0.002 in) |

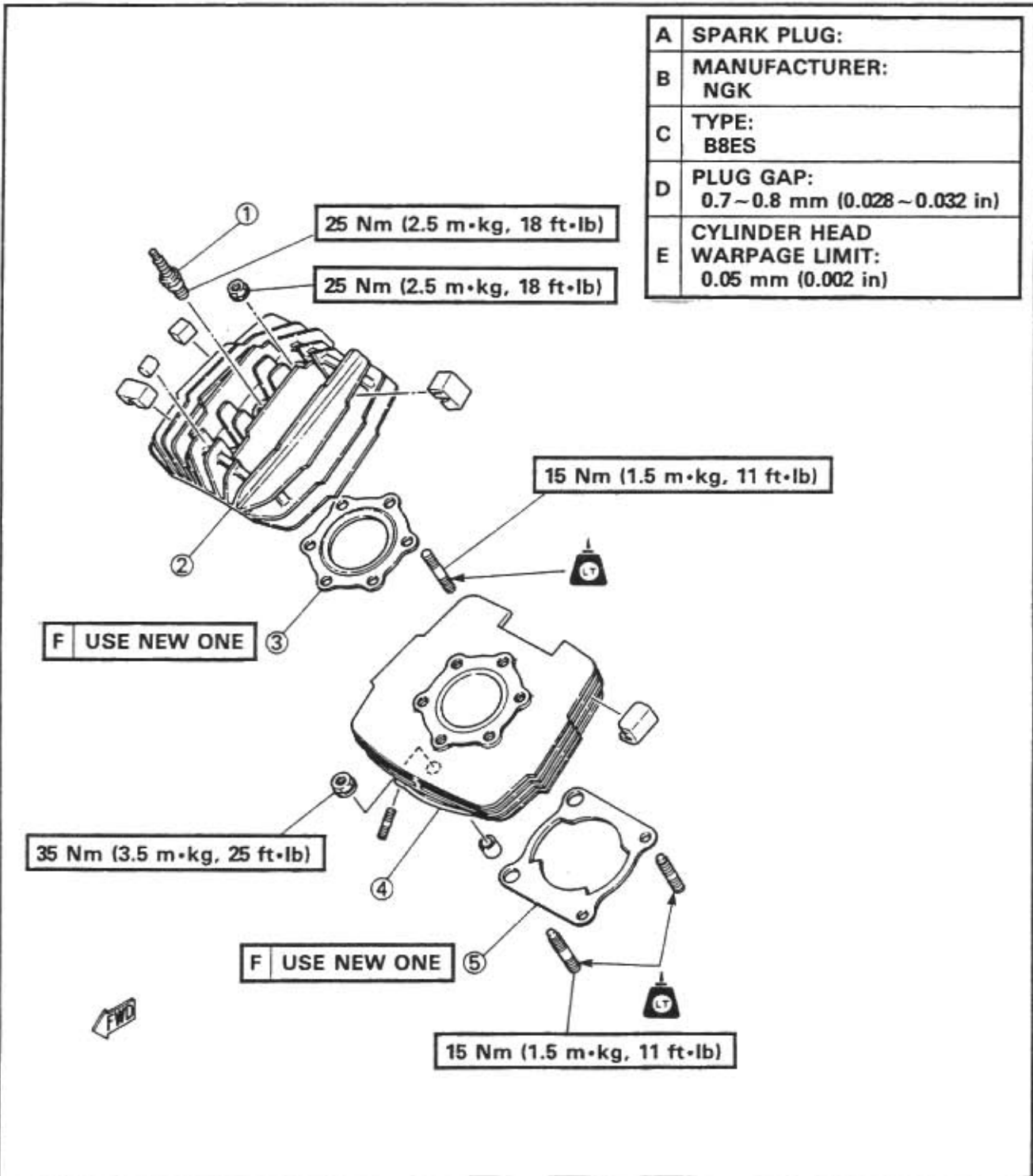



⚠ WARNING

Always use a new piston pin clip.

CAUTION:

Do not allow the clip open ends to meet the piston pin slot.



1. Install:

- Dowel pins ①
- Gasket (cylinder) ②

⚠ WARNING

Always use a new gasket.

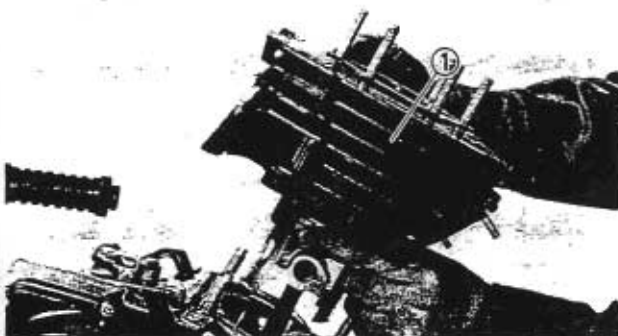

2. Install:

- Cylinder ①

NOTE:

Install the cylinder with one hand while compressing the piston ring with the other hand.

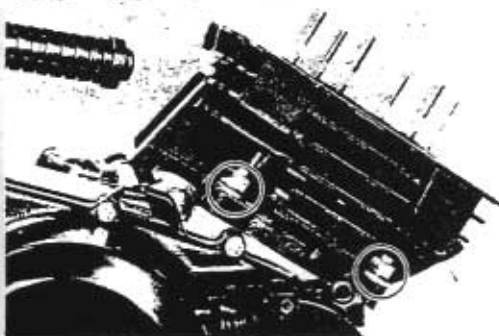

3. Tighten:

- Nut (cylinder)



Nut (cylinder):

35 Nm (3.5 m•kg, 25 ft•lb)

NOTE:

Tighten the nuts in stage, using a crisscross pattern.

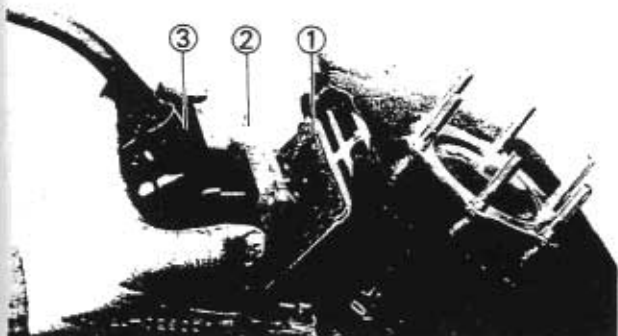

4. Install:

- Bulb seat gasket (new) ①
- Reed bulb assembly ②
- Carburetor joint ③

⚠ WARNING

A damaged gasket may cause the engine revs to accelerate. Make sure that a new gasket is used.

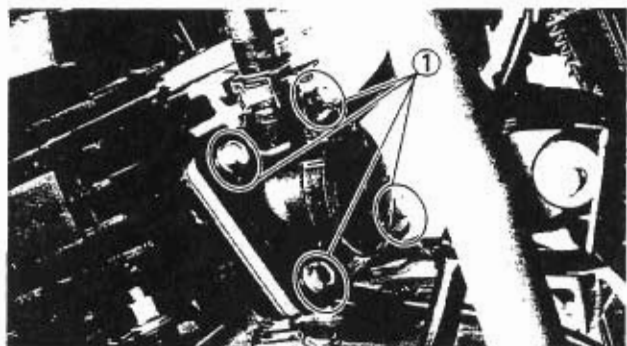

5. Tighten:
- Bolt (reed bulb) ①



Bolt (reed bulb):
8 Nm (0.8 m•kg, 5.8 ft•lb)

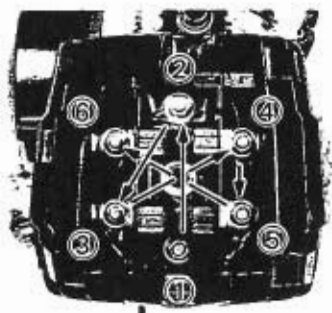

CYLINDER HEAD

1. Install:
- Gasket (cylinder head)
 - Cylinder head
 - Spark plug ①

⚠ WARNING

Always use a new gasket.

NOTE:

Tighten the nuts (cylinder head) in stage, using a crisscross pattern.



Nut (cylinder head):
25 Nm (2.5 m•kg, 18 ft•lb)
Spark plug:
25 Nm (2.5 m•kg, 18 ft•lb)

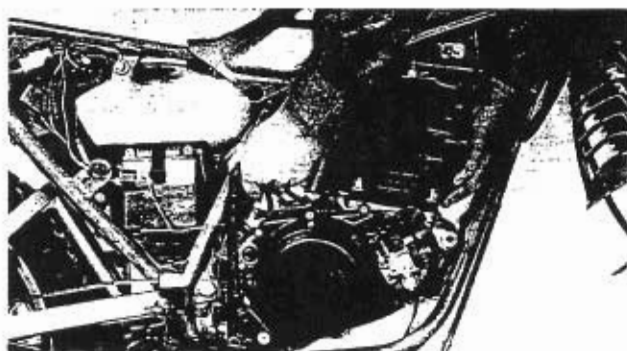

REMounting ENGINE

When remounting the engine, reverse the removal procedure. Note the following points.

1. Install:
- Engine assembly (from right side)
2. Install:
- Mounting bolt (front)
 - Mounting bolt (rear—lower)
 - Mounting bolt (rear—upper)



Engine mounting:
Bolt (front)
32 Nm (3.2 m•kg, 23 ft•lb)
Bolt (rear—lower)
39 Nm (3.9 m•kg, 28 ft•lb)
Bolt (rear—upper)
32 Nm (3.2 m•kg, 23 ft•lb)

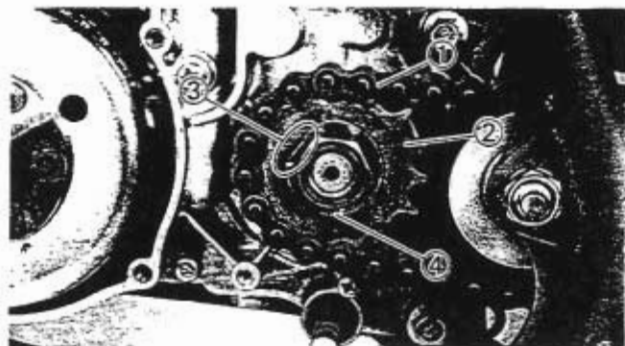

3. Install:

- Drive chain ①
- Drive sprocket ②
- Lock washer ③
- Nut (drive sprocket) ④



Nut (drive sprocket):
55 Nm (5.5 m·kg, 40 ft·lb)

NOTE:

- Tighten the nut (drive sprocket) while applying the rear brake.
- Bend the lock washer tab along the nut flat.

⚠ WARNING

Always use a new washer.

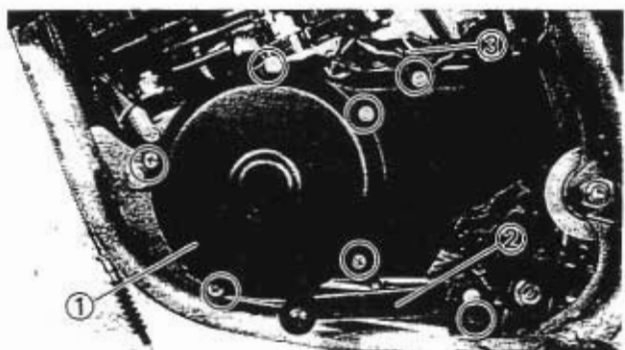

4. Install:

- Gasket (crankcase cover)
- Crankcase cover (left) ①
- Shift pedal ②
- Clamp ③

NOTE:

Tighten the screws (crankcase cover) in stage, using a crisscross pattern.



Screw (crankcase cover):
8 Nm (0.8 m·kg, 5.8 ft·lb)
Bolt (shift pedal):
11 Nm (1.1 m·kg, 8 ft·lb)

5. Adjust:

- Drive chain slack
Refer to the "DRIVE CHAIN SLACK ADJUSTMENT" section in the CHAPTER 3.



Drive chain slack:
35 ~ 40 mm (1.40 ~ 1.60 in)

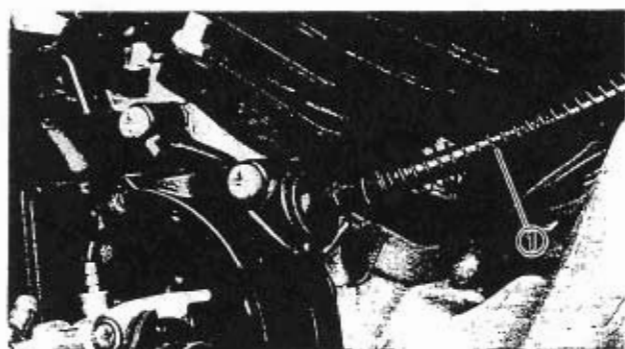

6. Install:
- Tachometer cable ①

7. Install:
- Carburetor assembly
- Refer to the "CARBURETOR ASSEMBLY" section in the CHAPTER 5.

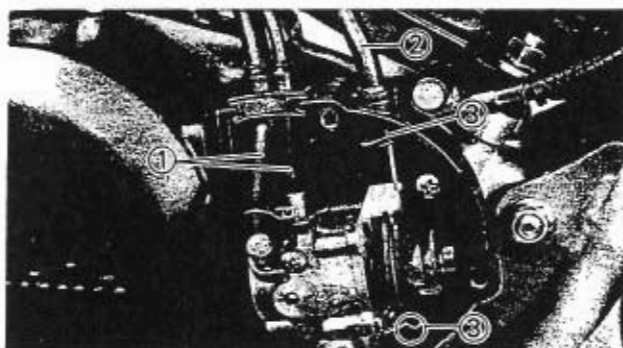

8. Install:
- Oil hose ①
 - Autolube pump cable ②
 - Clip ③
9. Adjust:
- Autolube pump cable
- Refer to the "AUTOLUBE PUMP CABLE ADJUSTMENT" section in the CHAPTER 3.

10. Air bleed:
- Autolube pump
- Refer to the "AUTOLUBE PUMP AIR BLEEDING" section in the CHAPTER 3.

11. Adjust:
- Throttle cable free play
- Refer to the "THROTTLE CABLE FREE PLAY ADJUSTMENT" section in the CHAPTER 3.

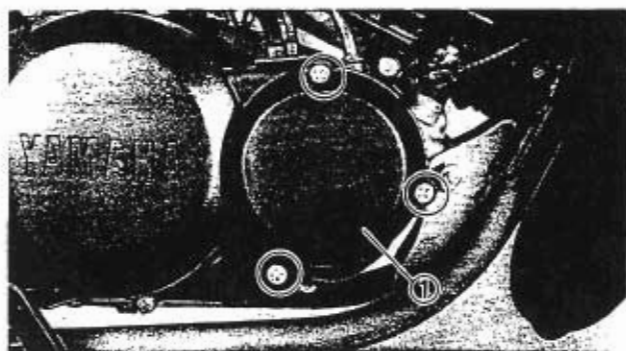

12. Install:
- Gasket (Autolube pump)
 - Autolube pump cover ①



Screw (Autolube pump cover):
8 Nm (0.8 m•kg, 5.8 ft•lb)

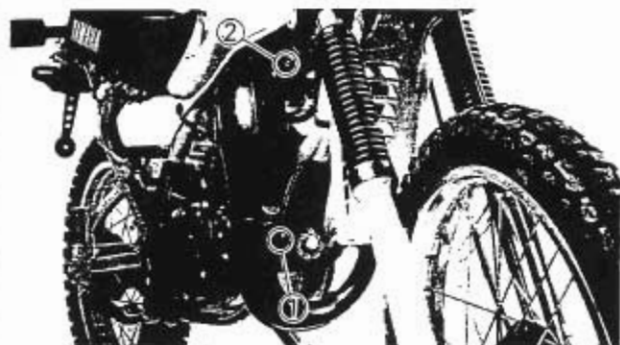

13. Install:

- Gasket (exhaust pipe)
- Exhaust pipe



Nut ① (exhaust pipe):
11 Nm (1.1 m•kg, 8 ft•lb)
Bolt ② (stay):
10 Nm (1.0 m•kg, 7.2 ft•lb)
Bolt ③ (frame mount):
10 Nm (1.0 m•kg, 7.2 ft•lb)
Screw ④ (muffler joint):
5 Nm (0.5 m•kg, 3.6 ft•lb)

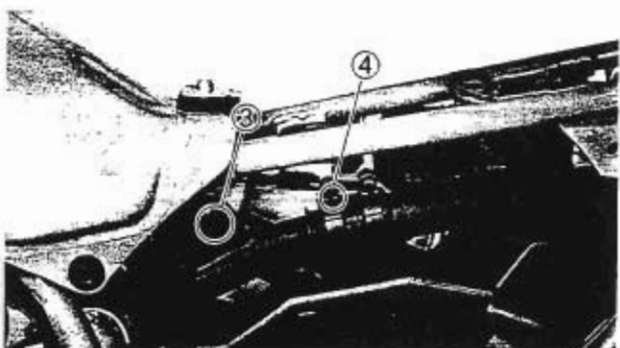

⚠ WARNING

Always use a new gasket.

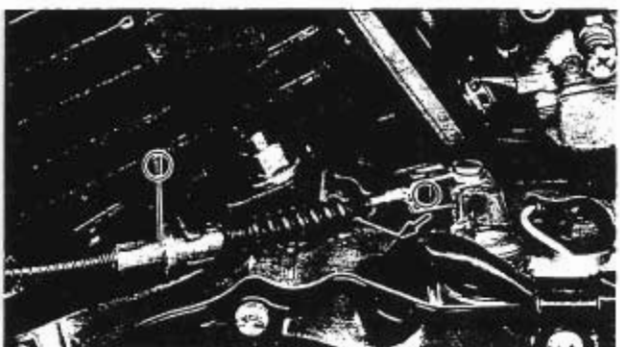

14. Install:

- Clutch cable (engine side) ①

NOTE:

Bend the holder portion of push lever axle.

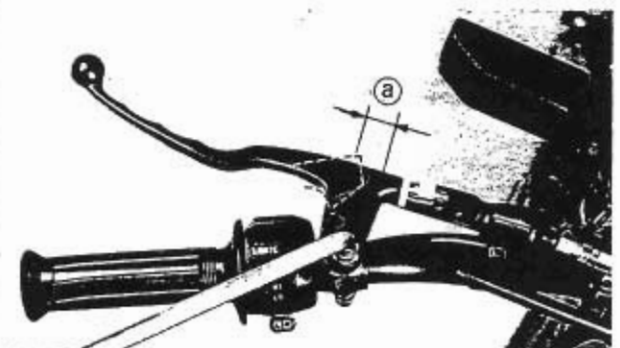

15. Adjust:

- Clutch cable free play (a)
Refer to the "CLUTCH ADJUSTMENT" section in the CHAPTER 3.



Free play:
2-3 mm (0.08-0.12 in)

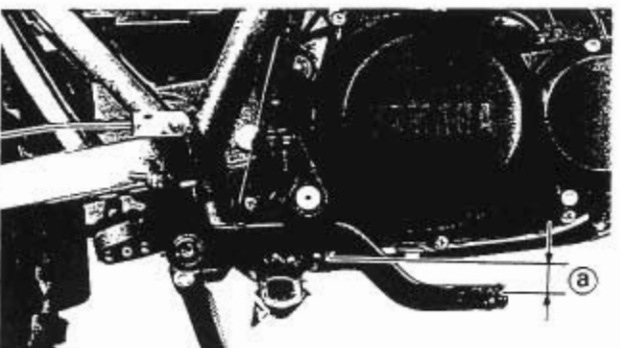

16. Adjust:

- Brake pedal height (a)
Refer to "CHAPTER 3-REAR BRAKE ADJUSTMENT".



Brake pedal height:
10 mm (0.4 in)

⚠ WARNING

Check the operation of the brake light after adjusting the brake pedal height.

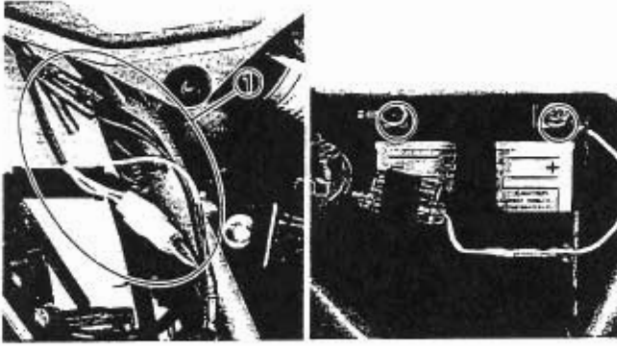

17. Connect:
- CDI magneto leads ①
 - Battery leads

CAUTION:

Connect the positive lead first and then connect the negative lead.

18. Fill:
- Crankcase

**Total amount:****0.65 L (0.57 Imp qt, 0.69 US qt)**

Refer to the "TRANSMISSION OIL REPLACEMENT" section in the CHAPTER 3.

CHAPTER 5. CARBURETION

| | |
|-------------------------|------|
| CARBURETOR | E-13 |
| REMOVAL | E-13 |
| DISASSEMBLY | E-13 |
| INSPECTION | E-14 |
| ASSEMBLY | E-15 |
| INSTALLATION | F-16 |
| ADJUSTMENT | F-16 |
| | |
| REED VALVE | F-1 |
| REMOVAL | F-1 |
| DISASSEMBLY | F-1 |
| INSPECTION | F-2 |
| ASSEMBLY | F-2 |
| INSTALLATION | F-2 |



CARBURETION

CARBURETOR

- ① Cap
- ② Throttle valve spring
- ③ Starter plunger
- ④ Throttle stop screw
- ⑤ Pilot air screw
- ⑥ Throttle valve
- ⑦ Needle set
- ⑧ Pilot jet
- ⑨ Needle jet
- ⑩ Gasket
- ⑪ Holder
- ⑫ Main jet
- ⑬ Needle valve assembly
- ⑭ Float
- ⑮ Drain screw

| SPECIFICATIONS | | |
|--------------------------|-------------------|--|
| MAIN JET (M.J.) | # 170 | |
| MAIN AIR JET (M.A.J.) | φ0.5 | |
| JET NEEDLE (J.N.) | 4L6-3 | |
| NEEDLE JET (N.J.) | O-8 | |
| PILOT JET (P.J.) | # 20 | |
| PILOT AIR SCREW (P.A.S.) | 1-1/2 | |
| FLOAT HEIGHT (F.H.) | 20~22 mm | |
| | (0.79~0.87 in) | |
| ENGINE IDLING SPEED | 1,300~1,400 r/min | |

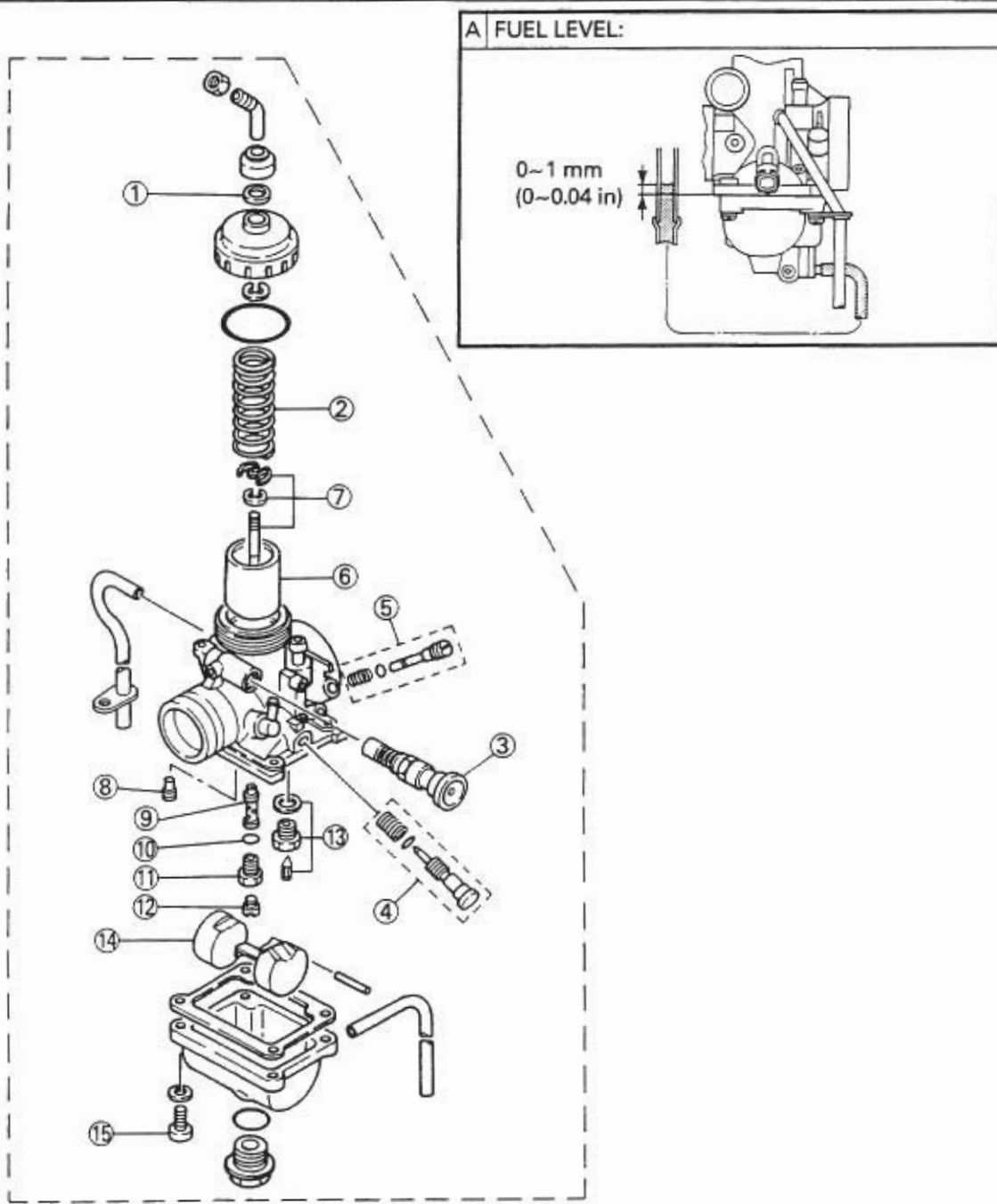

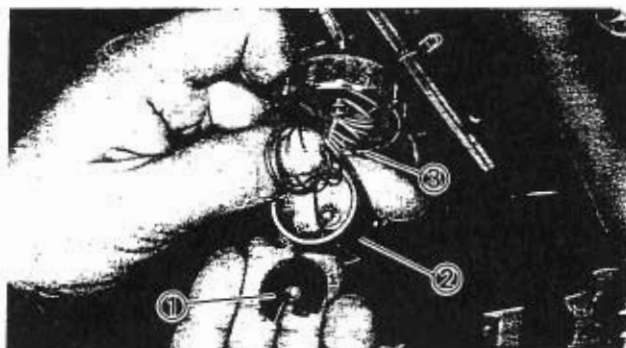
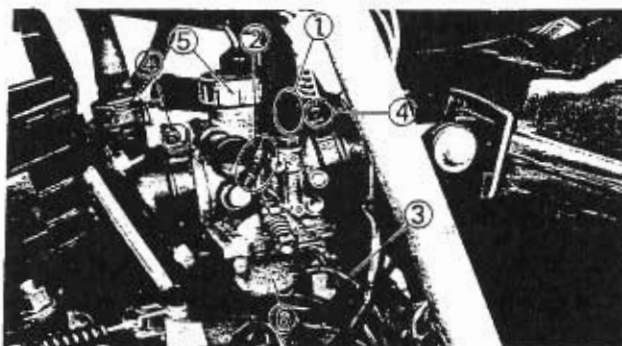

REMOVAL

1. Disconnect:
 - Fuel hose ①
 - Vacuum hose ②
 - Oil delivery hose ③
2. Loosen:
 - Screws (carburetor clamp) ④
3. Remove:
 - Carburetor top ⑤
 - Carburetor ⑥
4. Remove:
 - Cable holder ①
 - Throttle valve ②
 - Return spring ③

DISASSEMBLY

NOTE: _____

The following parts can be cleaned and inspected without carburetor separation.

(All inner parts except starter plunger can be cleaned and inspected without carburetor separation.)

- Throttle valve
- All jets
- Float
- Needle valve
- Valve seat
- Needle jet
- Jet needle

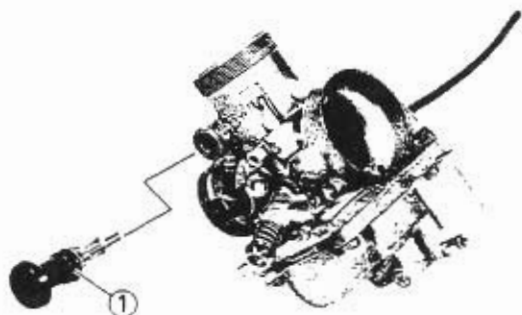

1. Remove:
 - Starter plunger ①

NOTE: _____

Unhook the hooks from the carburetor body and then pull out the starter plunger.

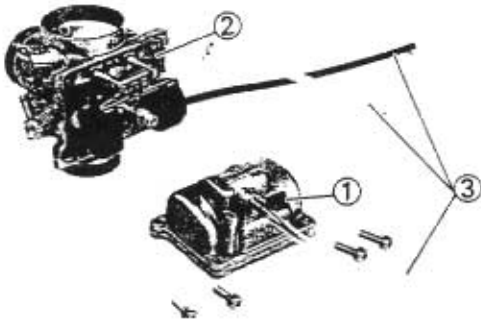

2. Remove:
- Float chamber ①
 - Gasket (float chamber) ②
 - Hose ③

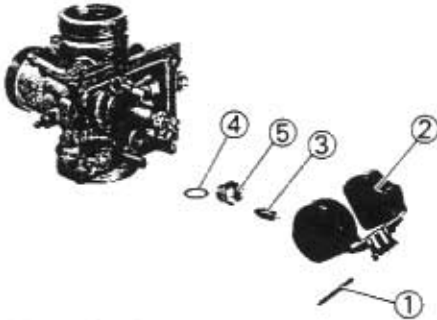

3. Remove:
- Float pin ①
 - Float ②
 - Needle valve ③
 - Gasket ④
 - Valve seat ⑤

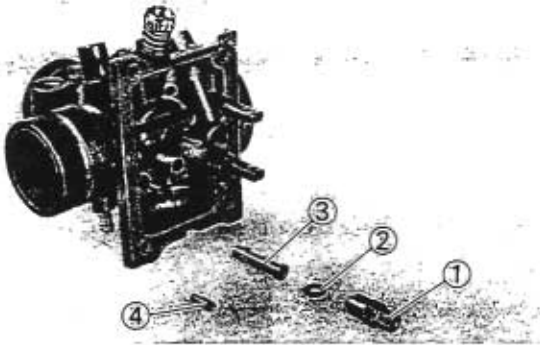

4. Remove:
- Main jet ①
 - O-ring ②
 - Needle jet ③
 - Pilot jet ④

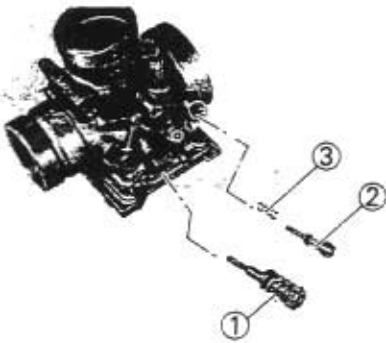

5. Remove:
- Throttle stop screw ①
 - Pilot air screw ②
 - Spring ③

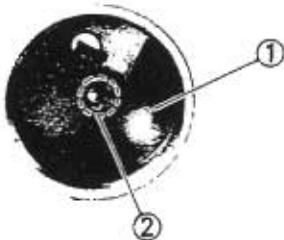

6. Remove:
- Jet needle holder ①
 - Jet needle ②

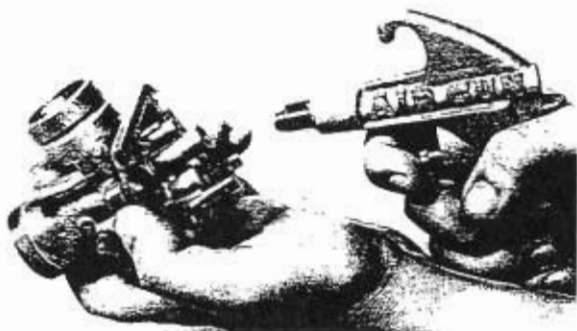
**INSPECTION**

1. Inspect:
 - Carburetor mixing chamber body
 - Carburetor float chamber body
 Contamination→Clean.

Cleaning steps:

- Wash carburetor in petroleum based solvent. (Do not use any caustic carburetor cleaning solution.)
 - Blow out all passages and jets with compressed air.
- *****

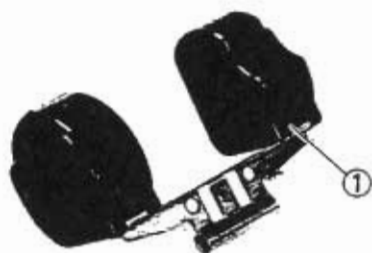

2. Inspect:
 - Float ①
 Damage→Replace.



3. Inspect:
 - Needle valve ①
 - Valve seat ②
 - Gasket ③
 Wear/Damage/Contamination→Replace as a set.

NOTE: _____
 Always replace the needle valve and valve seat as a set.



4. Inspect:
 - Throttle valve
 Scratches/Wear/damage→Replace.

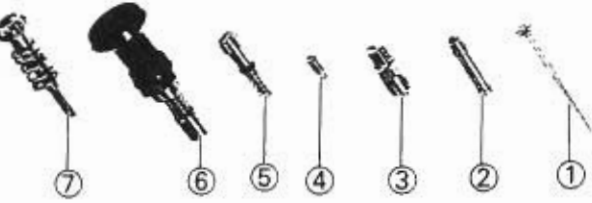

5. Inspect:

- Jet needle ①
- Needle jet ②
- Main jet ③
- Pilot jet ④
- Pilot air screw ⑤
- Starter plunger ⑥
- Throttle stop screw ⑦

Bends/Wear/Damage→Replace.

Contamination→Blow out jets with compressed air.

6. Check:

- Free movement

Insert the throttle valve into the carburetor body, and check free movement.

Stick→Replace.

7. Check:

- Free movement

Insert the starter plunger into the carburetor body, and check for free movement.

Stick→Replace.

ASSEMBLY

Reverse the "DISASSEMBLY" procedures.

Note the following points.

CAUTION:

- Before reassembling, wash the all parts with a clean gasoline.
- Always use a new gasket.

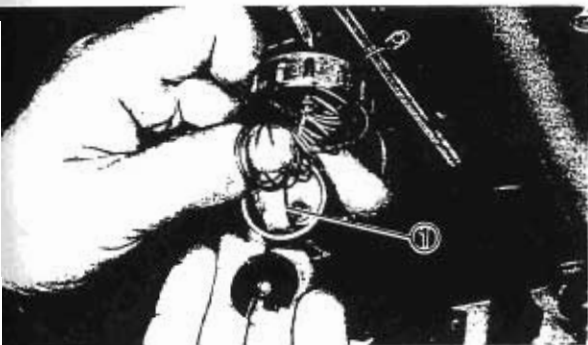

1. Connect:

- Throttle cable ①

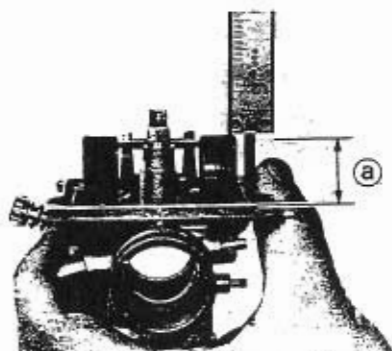
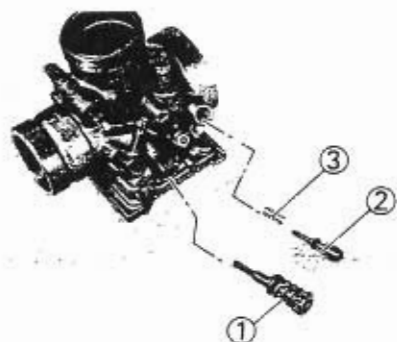
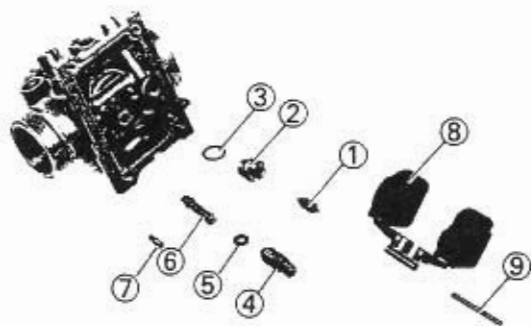

2. Install:

- Needle valve (1)
- Valve seat (2)
- Gasket (3)
- Main jet (4)
- O-ring (5)
- Jet needle (6)
- Pilot jet (7)
- Float (8)
- Float pin (9)

3. Install:

- Throttle stop screw (1)
- Pilot air screw (2)
- Spring (3)

4. Measure:

- Float height (a)
- Out of specification → Adjust.

| | |
|--|--|
| | <p>Float height (F.H.): 20~22 mm (0.79~0.87 in)</p> |
|--|--|

Measurement and adjustment steps:

- Hold the carburetor in an upside down position.
- Measure the distance from the mating surface of the float chamber (gasket removed) to the top of the float.

NOTE:

The float arm should be resting on the needle valve, but not compressing the needle valve.

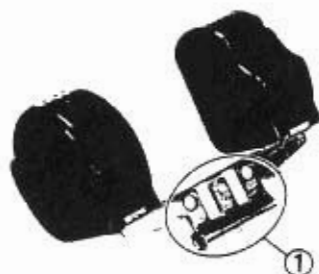

- If the float height is not within specification, inspect the valve seat and needle valve.
- If either is worn, replace them both.
- If both are fine, adjust the float height by bending the float tang (1) on the float.
- Recheck the float height.

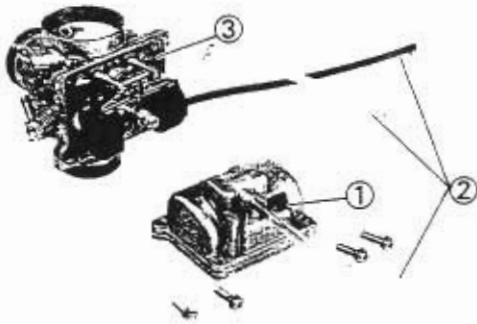

5. Install:
 - Float chamber ①
 - Hose ②
 - Gasket (float chamber) ③
6. Tighten:
 - Screws (float chamber)

| | |
|--|---|
| | Screw (float chamber): 2 Nm (0.2 m • kg, 1.4 ft • lb) |
|--|---|

7. Install:
 - Starter plunger ①

| | |
|--|---|
| | Nut (starter plunger): 3 Nm (0.3 m • kg, 2.2 ft • lb) |
|--|---|

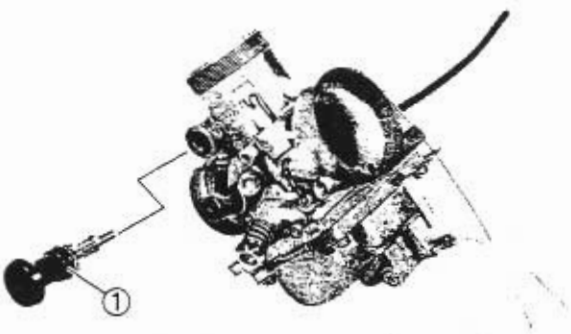

8. Install:
 - Throttle valve

NOTE: _____
 Align the groove (a) of the throttle valve with the projection (b) of the carburetor body.

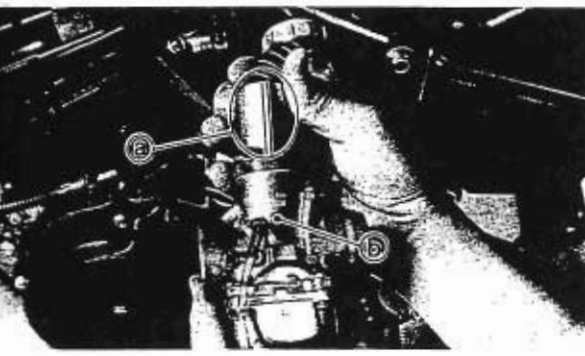

INSTALLATION

Reverse the "REMOVAL" procedures.
 Note the following points.

1. Install:
 - Carburetor assembly ①

NOTE: _____
 Align the groove (a) of the carburetor joint with the projection (b) of the carburetor body.

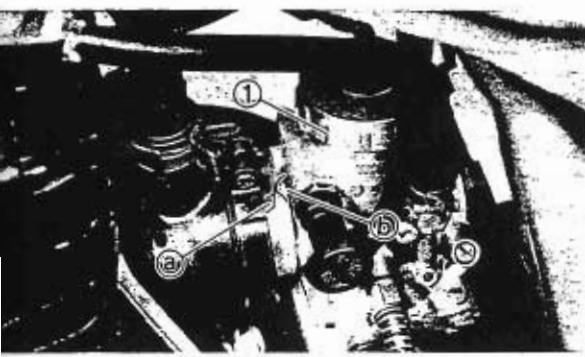

2. Adjust:
 - Idle speed

Refer to the "IDLE SPEED ADJUSTMENT" section in the CHAPTER 3.

| | |
|--|--|
| | Engine idle speed: 1,300~1,400 r/min |
|--|--|



3. Adjust:

- Throttle cable free play

Refer to the "THROTTLE CABLE FREE PLAY ADJUSTMENT" section in the CHAPTER 3.



Throttle cable free play:
2-5 mm (0.08-0.20 in)

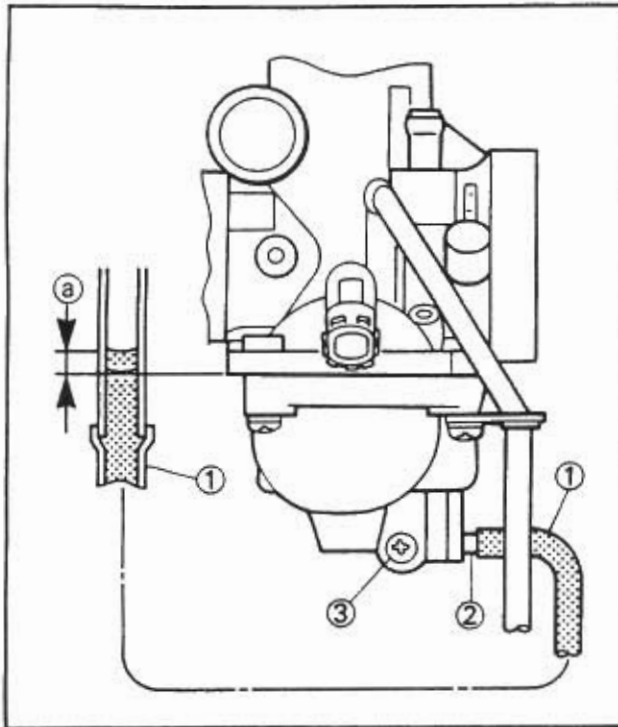

ADJUSTMENT

Fuel Level Adjustment

1. Measure:

- Fuel level (a)

Out of specification → Adjust.



Fuel level (a):
0 - 1 mm (0 - 0.04 in)
In the middle of the float chamber
above the carburetor body edge.

Fuel level measurement and adjustment steps:

- Place the motorcycle on a level surface.
- Use a garage jack under the engine to ensure that the carburetor is positioned vertically.
- Connect the fuel level gauge (1) to the drain pipe (2).



Fuel level gauge:
90890-01312

- Loosen the drain screw (3) and warm up the engine for several minutes.
- Measure the fuel level a with the gauge.
- If the fuel level is incorrect, adjust the fuel level.
- Remove the carburetor.
- Inspect the valve seat and needle valve.
- If either is worn, replace them both.
- If both are fine, adjust float level by bending the float tang (4) slightly.
- Install the carburetor.
- Recheck the fuel level.

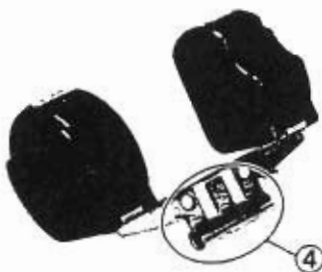



REED VALVE

- ① Reed valve assembly
- ② Reed valve
- ③ Reed valve stopper
- ④ Gasket
- ⑤ Carburetor joint
- ⑥ ENERGY Induction chamber

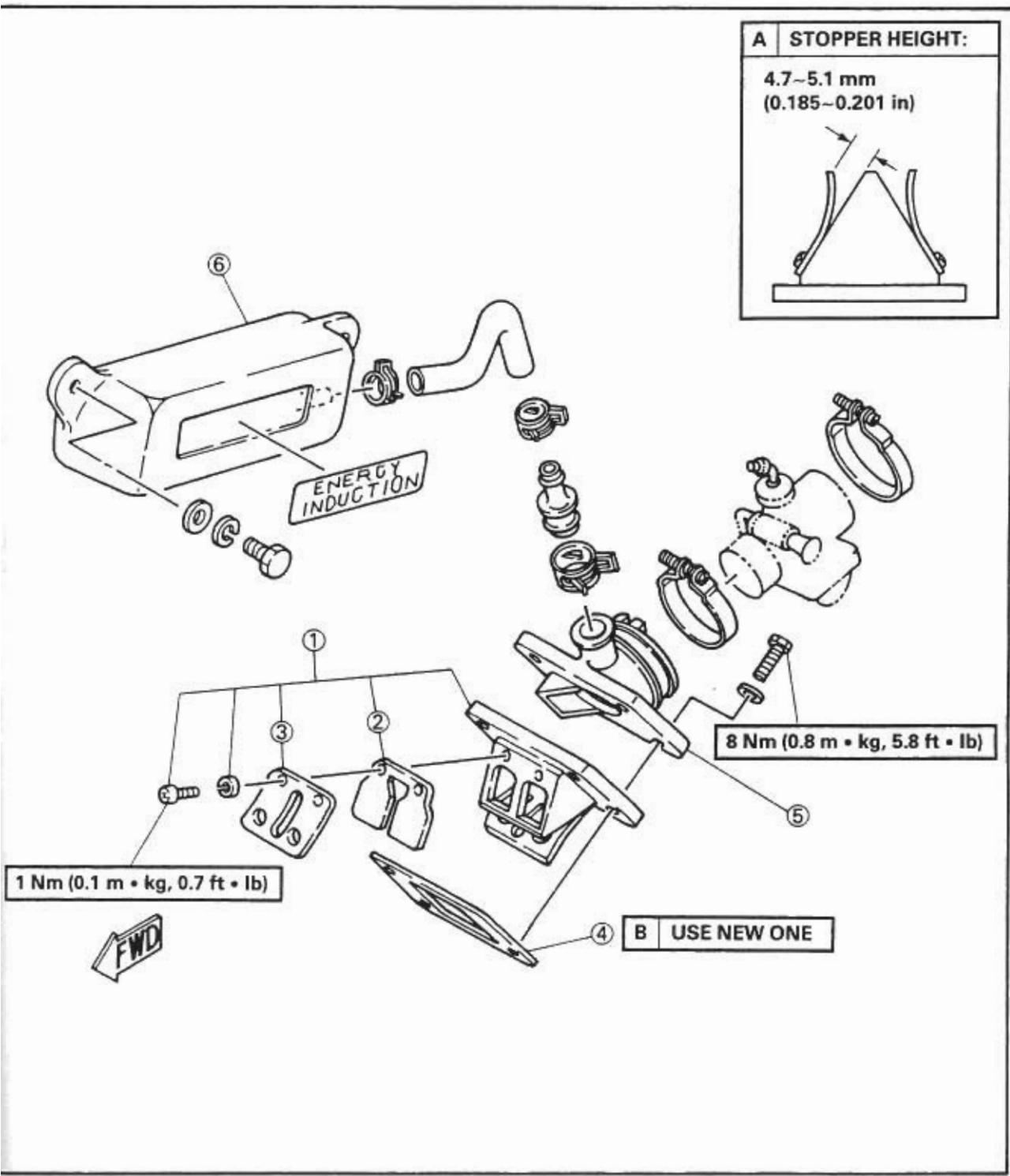
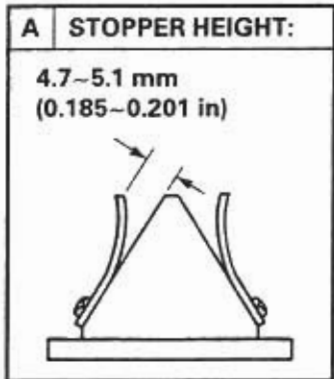



REMOVAL

1. Remove:
 - Carburetor
Refer to the "CARBURETOR—REMOVAL" section.

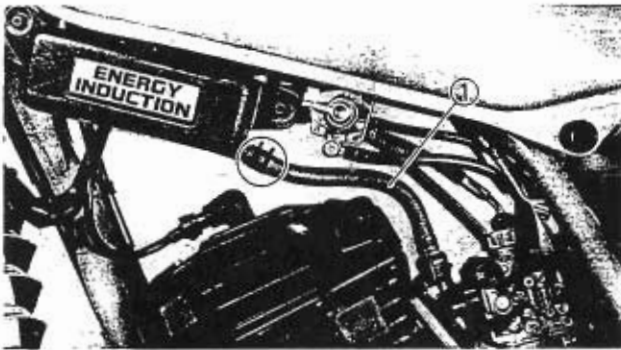

2. Disconnect:
 - Hose (energy induction) ①

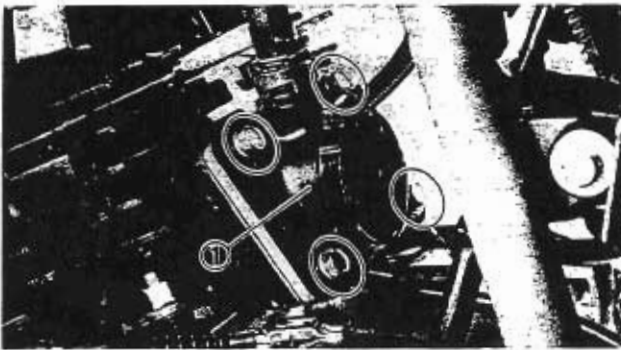

3. Remove:
 - Carburetor joint ①

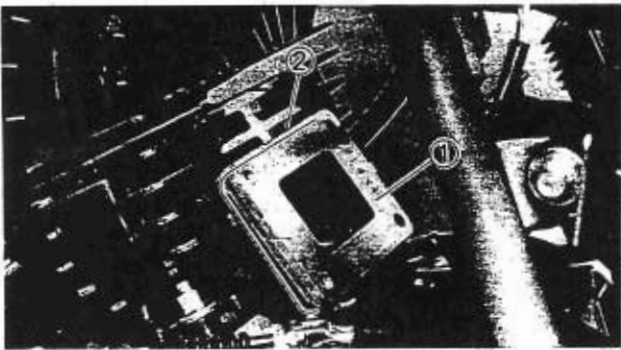

4. Remove:
 - Reed valve assembly ①
 - Gasket ②

DISASSEMBLY

1. Remove:
 - Reed valve stopper ①
 - Reed valve ②

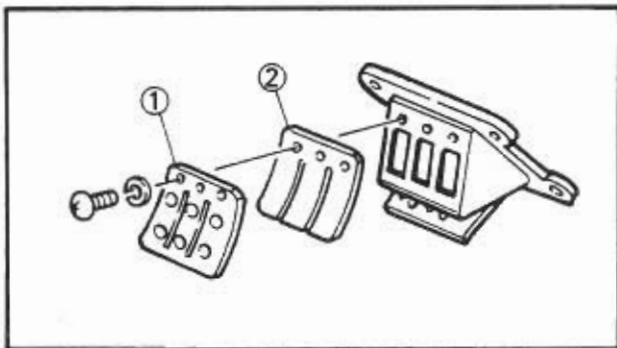

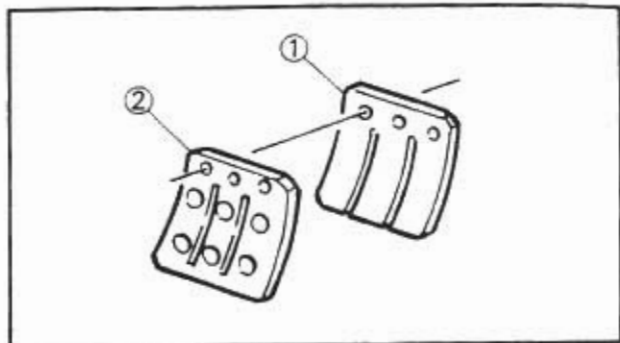

INSPECTION

1. Inspect:

- Reed valve ①
 - Reed valve stopper ②
- Cracks/Damage→Replace.

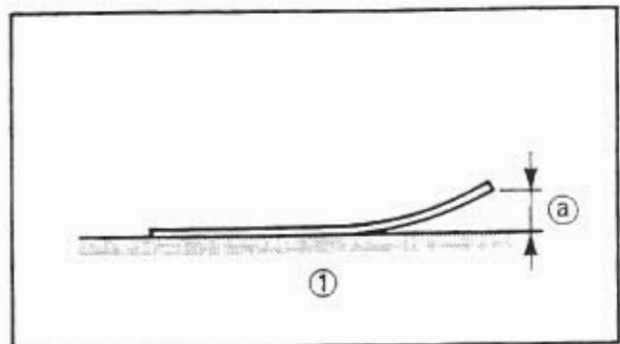

2. Measure:

- Reed valve bending limit (a)
- Out of specification→Replace.

| | |
|--|--|
| | Reed valve bending limit: 0.5 mm (0.02 in) |
|--|--|

① Surface plate

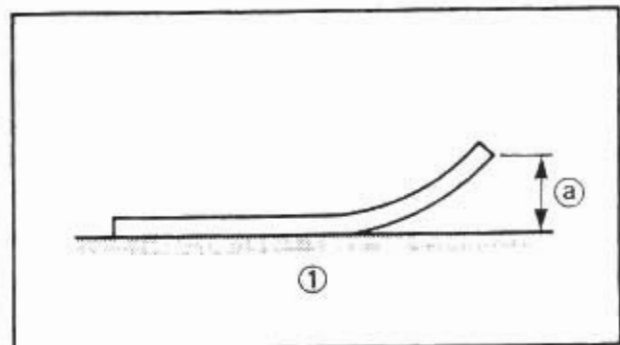

3. Measure:

- Reed valve stopper height (a)
- Out of specification→Replace.

| | |
|--|--|
| | Reed valve stopper height: 4.7~5.1 mm (0.185~0.201 in) |
|--|--|

① Surface plate

4. Inspect:

- Carburetor joint ①
- Cracks/Damage→Replace.

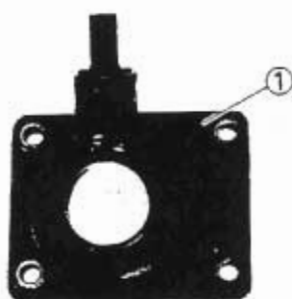

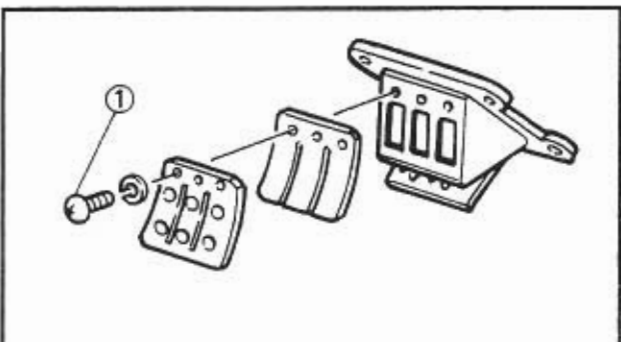
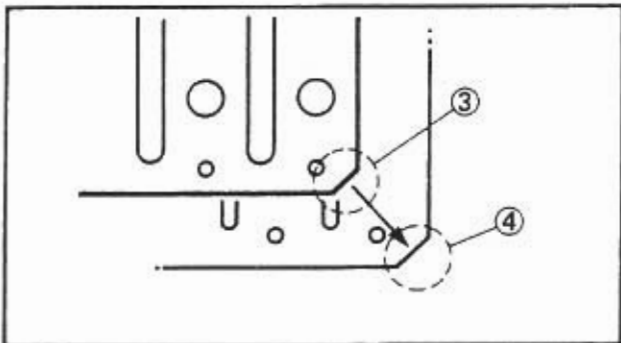
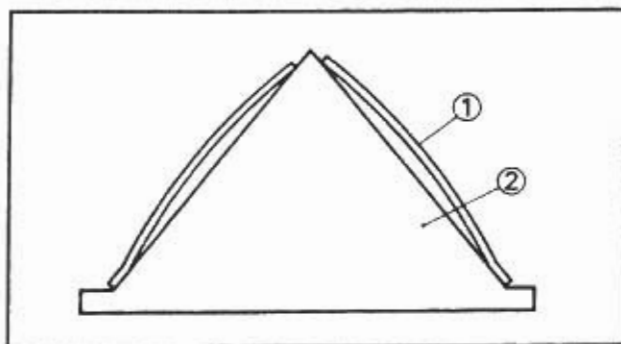

ASSEMBLY

Reverse the "DISASSEMBLY" procedure. Note the following points.

1. Install:
 - Reed valves
 - Reed valve stoppers

NOTE:

- Place the reed valve ① with its concave facing the reed valve seat ②.
- Fit the reed valve stopper cut ③ with the corresponding cut ④ on the reed valve.

2. Tighten:
 - Screws (reed valve) ①

| | |
|--|--|
| | <p>Screw (reed valve): 1 Nm (0.1 m • kg, 0.7 ft • lb)</p> |
|--|--|

NOTE:

Tighten each screw gradually to avoid warping.

INSTALLATION

Reverse the "REMOVAL" procedure. Note the following points.

1. Install:
 - Gasket (new) ①
 - Reed valve assembly ②

⚠ WARNING

A damaged gasket may cause the engine revs to accelerate. Make sure that a new gasket is used.

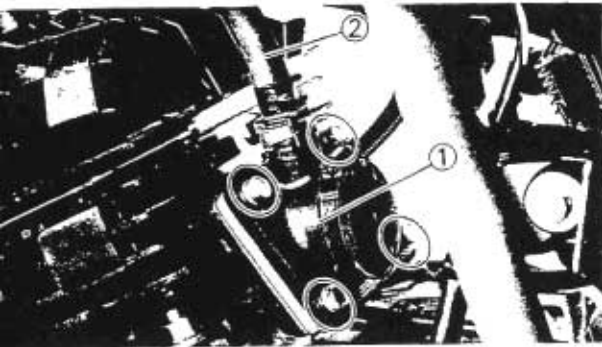

2. Install:
 - Carburetor joint ①
3. Connect:
 - Hose (energy induction) ②
4. Tighten:
 - Bolts (carburetor joint)



Bolt (carburetor joint):
8 Nm (0.8 m • kg, 5.8 ft • lb)

3. Install:
 - Carburetor



CHAPTER 6. CHASSIS

| | |
|---|------|
| FRONT WHEEL | F-7 |
| REMOVAL | F-7 |
| INSPECTION | F-8 |
| ASSEMBLY | F-9 |
| INSTALLATION | F-10 |
| STATIC WHEEL BALANCE ADJUSTMENT | F-10 |
| REAR WHEEL | F-11 |
| REMOVAL | F-12 |
| INSPECTION | F-12 |
| ASSEMBLY | F-12 |
| INSTALLATION | F-13 |
| STATIC WHEEL BALANCE ADJUSTMENT | F-14 |
| FRONT FORK | F-14 |
| REMOVAL | F-15 |
| DISASSEMBLY | F-15 |
| INSPECTION | H-16 |
| ASSEMBLY | F-16 |
| INSTALLATION | G-2 |
| STEERING HEAD AND HANDLEBARS | G-2 |
| REMOVAL | G-3 |
| INSPECTION | G-5 |
| INSTALLATION | G-5 |
| REAR SHOCK ABSORBER AND SWINGARM | G-8 |
| HANDLING NOTES | G-9 |
| NOTES ON DISPOSAL | G-9 |
| REMOVAL | G-9 |
| INSPECTION | G-10 |
| INSTALLATION | G-11 |
| DRIVE CHAIN AND SPROCKETS | G-12 |
| REMOVAL | G-13 |
| INSPECTION | G-13 |
| INSTALLATION | G-14 |

CHASSIS

FRONT WHEEL

- ① Wheel axle
- ② Collar
- ③ Oil seal
- ④ Bearing
- ⑤ Collar
- ⑥ Front wheel
- ⑦ Bearing
- ⑧ Brake shoe set
- ⑨ Brake shoe plate
- ⑩ Gear set (speedometer)

| | | |
|--|---|---|
| Basic weight: With oil and full fuel tank | 107 kg (236 lb) | |
| Maximum load* | 213 kg (470 lb) | |
| Cold tire pressure | Front | Rear |
| Up to 90 kg (198 lb) load* | 150 kPa (1.5 kg/cm ² , 21 psi) | 200 kPa (2.0 kg/cm ² , 29 psi) |
| 90 kg (198 lb)– Maximum load* | 150 kPa (1.5 kg/cm ² , 21 psi) | 230 kPa (2.3 kg/cm ² , 33 psi) |
| Off-road riding | 150 kPa (1.5 kg/cm ² , 21 psi) | 200 kPa (2.0 kg/cm ² , 28.5 psi) |

*Load is the total weight of cargo, rider, passenger, and accessories.

| | |
|----------|---|
| A | TIRE SIZE: 7.25-21 4PR |
| B | RIM SIZE: 1.60×21 |
| C | RIM RUNOUT LIMIT: VERTICAL: 2.0 mm (0.08 in) LATERAL: 2.0 mm (0.08 in) |

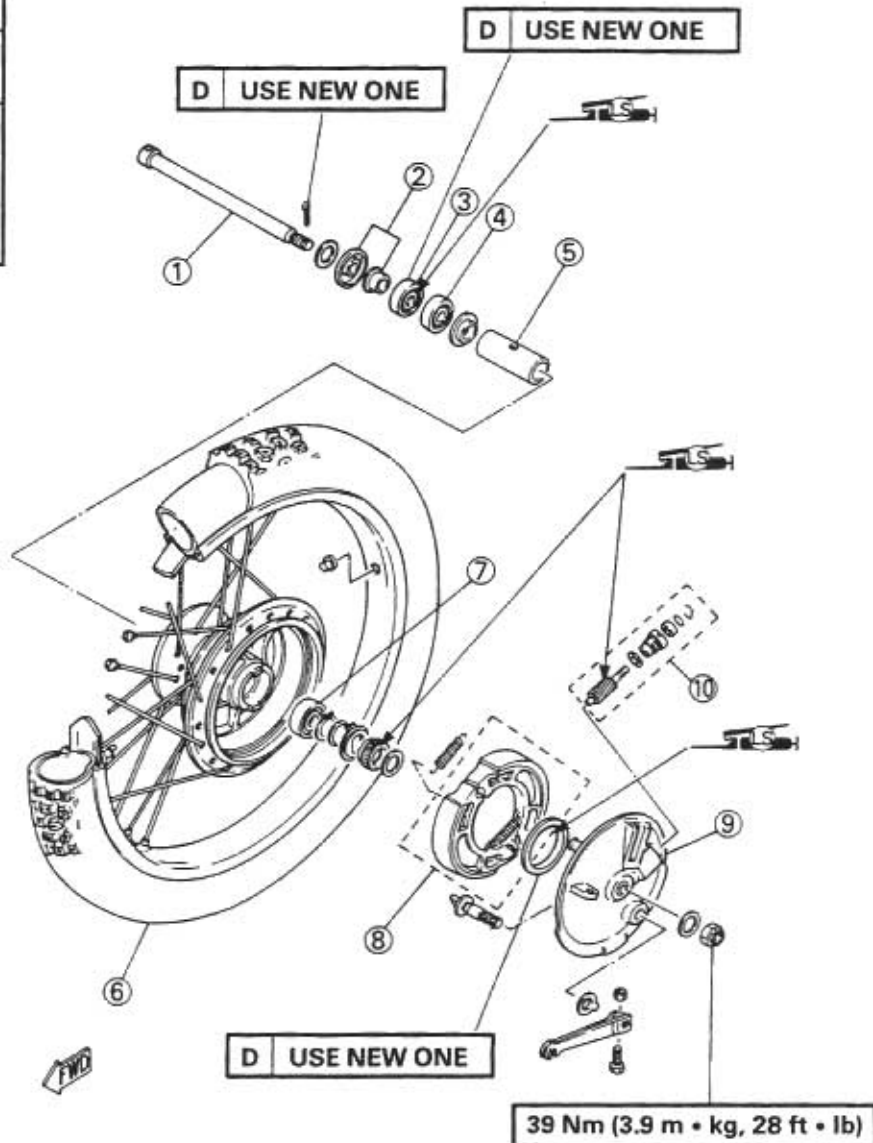



REMOVAL

⚠ WARNING

Securely support the motorcycle so there is no danger of it falling over.

1. Place the motorcycle on a level place.

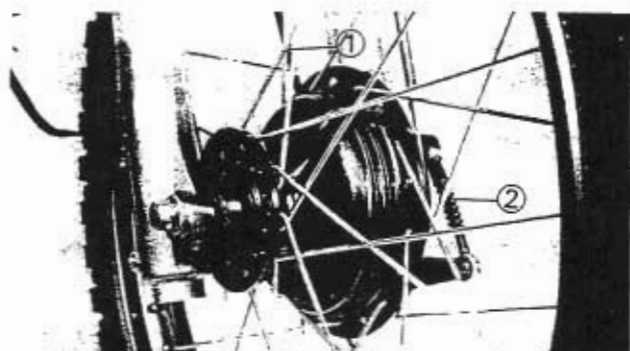

2. Remove:

- Speedometer cable (1)
- Brake cable (2)

NOTE:

Do not depress the brake lever when the wheel is off the motorcycle otherwise the brake pads will be forced shut.

3. Elevate the front wheel by placing a suitable stand under the engine.

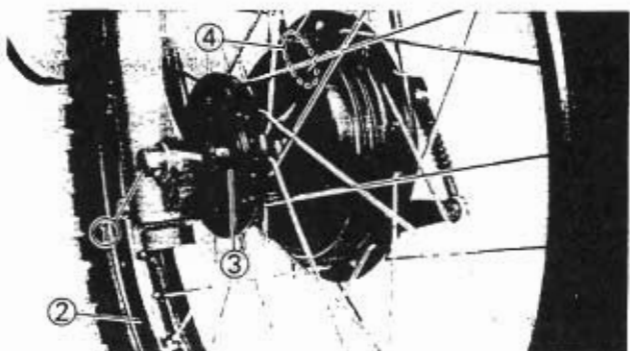

4. Remove:

- Front wheel axle (1)
- Front wheel (2)
- Spacer collar (3)
- Speedometer driven gear (4)

5. Remove:

- Camshaft lever (1)



6. Remove:

- Wear indicator (1)

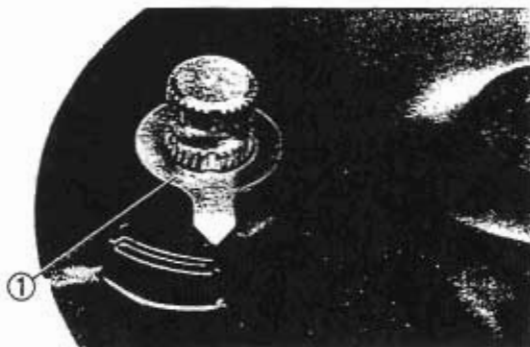

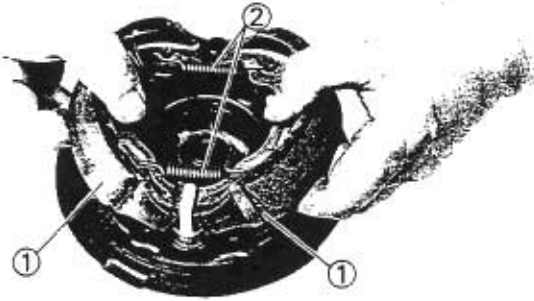

7. Remove:

- Brake shoe ①
- Return spring ②

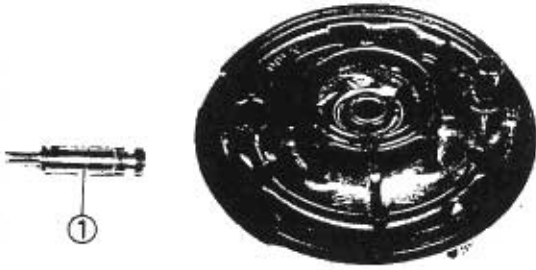

8. Remove:

- Brake camshaft ①

INSPECTION

1. Inspect:

- Front axle
Roll the axle on a flat surface.
Bends → Replace.

⚠ WARNING

Do not attempt to straighten a bent axle.

2. Inspect:

- Tire
Wear/Damage → Replace.
Refer to the "TIRE INSPECTION" section in the CHAPTER 3.
- Wheel
Refer to the "WHEEL INSPECTION" section in the CHAPTER 3.

3. Measure:

- Wheel runout
Over specified limit → Replace.



Rim runout limit:

Vertical ①: 2.0 mm (0.08 in)

Lateral ②: 2.0 mm (0.08 in)

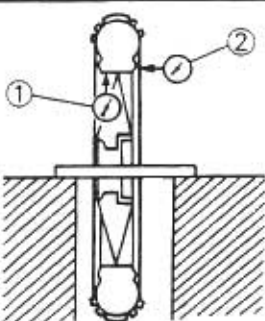

340 002

340-008

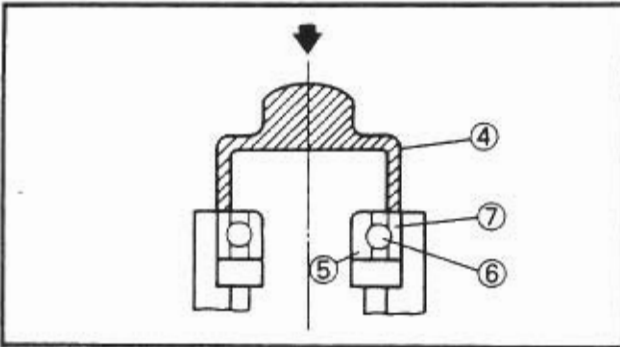
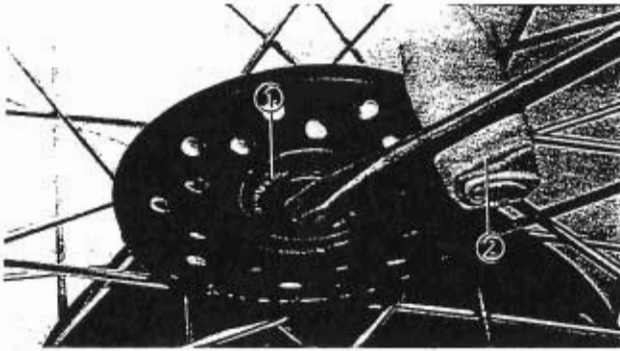
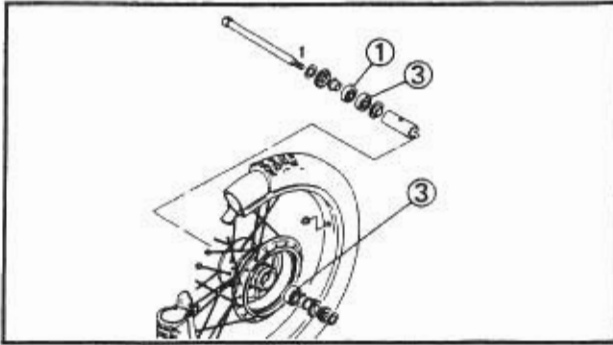

4. Inspect:

• Wheel bearings

Bearings allow play in the wheel hub or wheel turns roughly→Replace.

• Oil seals

Wear/Damage→Replace.

Wheel bearing and oil seal replacement steps:

● Clean the outside of the wheel hub.

● Remove the oil seals ① use a flat-head screw driver.

NOTE: _____

Place a rag ② on the outer edge to prevent damage.

● Remove the bearing ③ using a general bearing puller.

● Install the new bearing and oil seal by reversing the previous steps.

NOTE: _____

Use a socket ④ that matches the outside diameter of the race of the bearing and oil seal.

CAUTION: _____

Do not strike the center race ⑤ or balls ⑥ of the bearing. Contact should be made only with the outer race ⑦.

5. Inspect:

• Brake shoes

Glazed parts→Sand with coarse sandpaper.

NOTE: _____

After using the sandpaper, clean of the polished particles with a cloth.



6. Measure:

- Brake shoe thickness (a)
Out of specification → Replace.

**Brake shoe thickness:**

Standard: 4 mm (0.157 in)

Limit: 2 mm (0.079 in)

7. Inspect:

- Brake drum inner surface
Oil/Scratches → Remove.

| | |
|-----------|--|
| Oil | Use a rag soaked in lacquer thinner or solvent. |
| Scratches | Use an emery cloth (Lightly and evenly polishing.) |

8. Measure:

- Brake drum inside diameter (a)
Out of specification → Replace.

**Brake drum wear limit:**

131 mm (5.16 in)

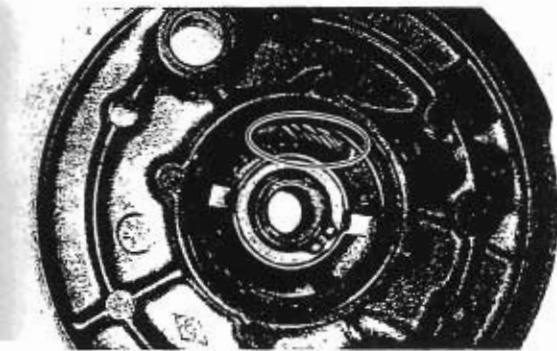
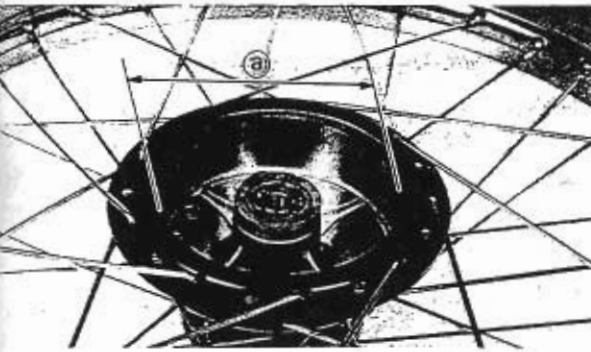

9. Inspect:

- Speedometer drive gear
- Speedometer driven gear
Wear/Damage → Replace.

ASSEMBLY

When assembling the brake shoe plate, reverse the removal procedure.

Note the following points.

1. Apply:

- Lithium-soap base grease
(to speedometer driven gear and oil seal.)

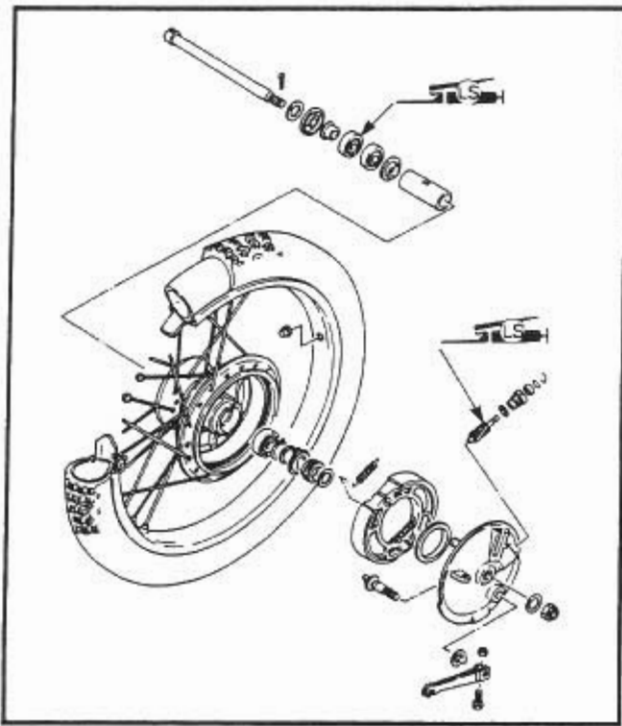

2. Apply:

- Lithium-soap base grease
(to speedometer drive gear and dust seal.)

3. Install:

- Dust seal (new)

NOTE: _____

Install the dust seal with the manufacture's marks or numbers facing outward.

4. Install:

- Brake camshaft ①

NOTE: _____

Apply the lithium soap base grease onto the brake camshaft and pin.

CAUTION: _____

After installing the brake camshaft, wipe off the excess grease.

5. Install:

- Brake shoe ①
- Return spring ②

CAUTION: _____

When installing the brake shoe, take care not to apply grease to the brake shoe.

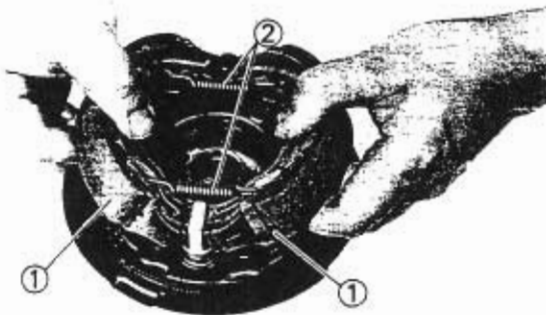

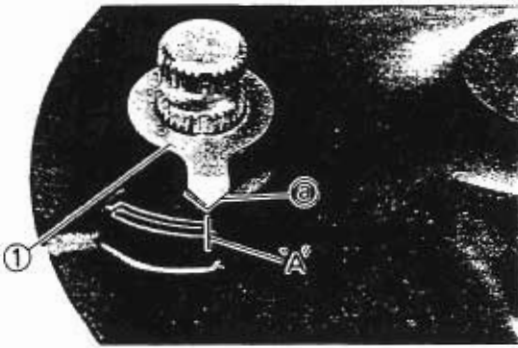

6. Install:
- Wear indicator ①

NOTE: _____
Align the wear indicator projection (a) with "A" line as shown.

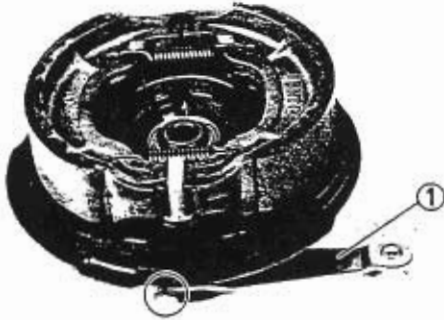

7. Install:
- Camshaft lever ①

| | |
|---|---|
|  | Bolt (camshaft lever): 8 Nm (0.8 m • kg, 5.8 ft • lb) |
|---|---|

8. Check:
- Brake shoe operation
- Unsmoothly operation—Repair.

INSTALLATION

Reverse the "Removal" procedure.
Note the following points.

1. Install:
- Brake shoe plate ①

NOTE: _____
Be sure the projections inside the gear unit are meshed with the flats in the wheel hub.

2. Install:
- Front wheel

NOTE: _____
Be sure the boss on the front fork correctly engages with the locating slot on the brake shoe plate assembly.

3. Install:
- Speedometer drive gear ①
 - Speedometer cable ②
 - Brake cable ③
 - Front axle nut ④

| | |
|---|--|
|  | Nut (front wheel axle): 39 Nm (3.9 m • kg, 28 ft • lb) |
|---|--|



4. Adjust:
 - Front brake lever free play
 Refer to "FRONT BRAKE ADJUSTMENT" section in the CHAPTER 2.



Front brake lever free play:
5-8 mm (0.20-0.32 in)

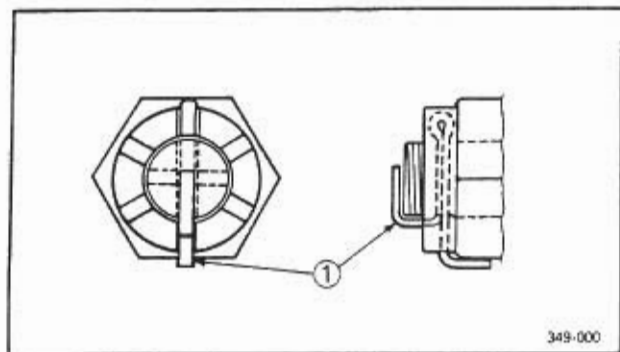

5. Install:
 - Cotter pin ①

NOTE: _____
Bend the ends of the cotter pin.

⚠ WARNING _____

Always use a new cotter pin.

STATIC WHEEL BALANCE ADJUSTMENT

NOTE: _____

- After replacing the tire and/or rim, wheel balance should be adjusted.
- Adjust the wheel balance with brake disc installed.

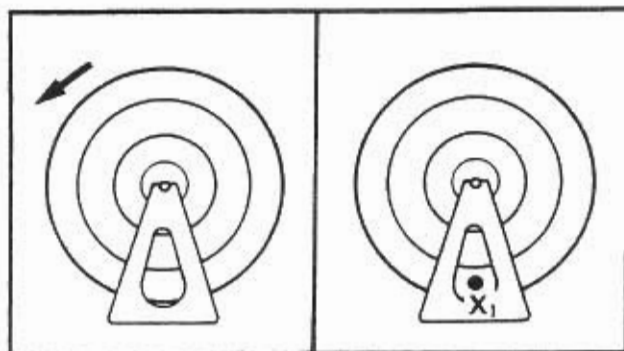

1. Remove:
 - Balancing weight
2. Set the wheel on a suitable stand.
3. Find:
 - Heavy spot

Procedure:

- Spin the wheel and wait for it to rest.
- Put an "X₁" mark on the wheel bottom spot.
- Turn the wheel so that the "X₁" mark is 90° up.

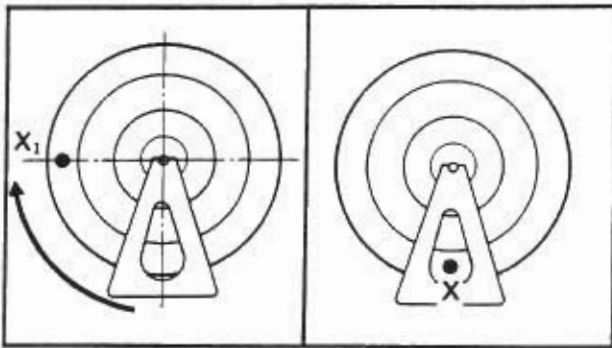

- Let the wheel fall and wait for it to rest.
- Put an "X₂" mark on the wheel bottom spot.
- Repeat the above steps several times until these marks come to the same spot.
- This spot is the heavy spot "X".

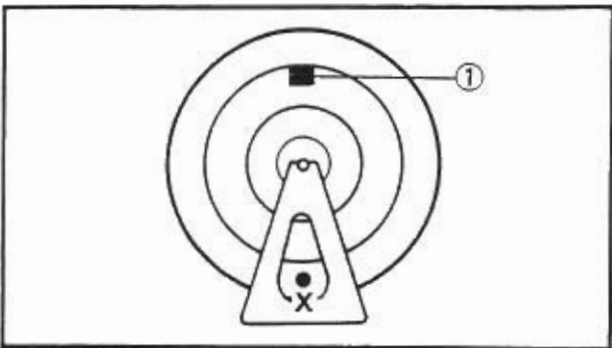

4. Adjust:
- Wheel balance

Adjustment steps:

- Install a balance weight ① on the rim exactly opposite to the heavy spot "X".

NOTE: _____

Start with the smallest weight.

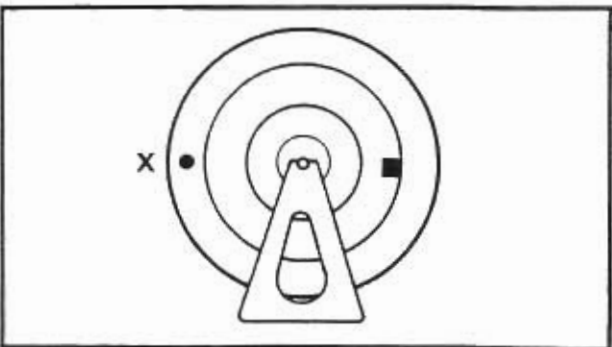

- Turn the wheel so that the heavy spot is 90° up.
- Check that the heavy spot is at rest there.
If not try another weight until the wheel is balanced.

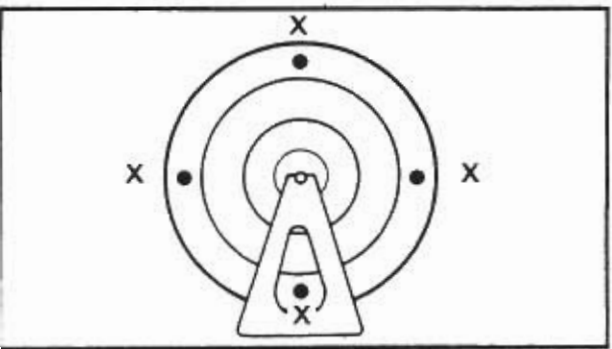

5. Check:
- Wheel balance

Checking steps:

- Turn the wheel so that it comes to each point as shown.
- Check that the wheel is at rest at each point. If not readjust the wheel balance.

REAR WHEEL

- ① Chain puller
- ② Dust cover
- ③ Collar
- ④ Oil seal
- ⑤ Bearing
- ⑥ Collar
- ⑦ Rear wheel
- ⑧ Driven sprocket
- ⑨ Bearing
- ⑩ Oil seal
- ⑪ Dust cover
- ⑫ Collar
- ⑬ Drive chain
- ⑭ Wheel axle
- ⑮ Brake shoe set
- ⑯ Brake shoe plate

| | |
|---|--|
| A | TIRE SIZE: 4.10-18 4PR |
| B | RIM SIZE: 1.85×18 |
| C | RIM RUNOUT LIMIT: VERTICAL: 2.0 mm (0.08 in) LATERAL: 2.0 mm (0.08 in) |

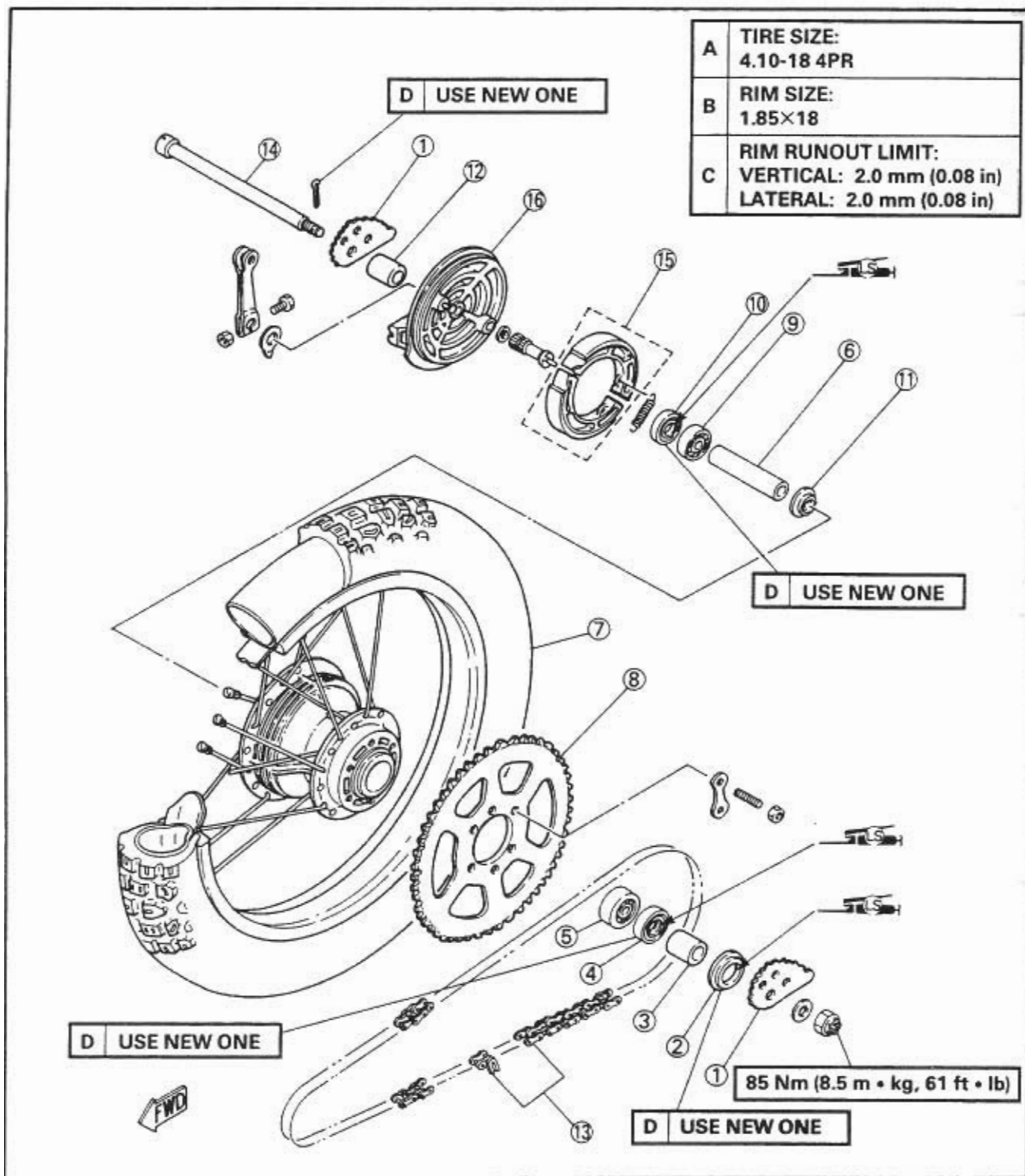



REMOVAL

⚠ WARNING

Securely support the motorcycle so there is no danger of it falling over.

1. Place the motorcycle on a level place.
2. Elevate the rear wheel by placing a suitable stand under the swingarm.

3. Remove:

- Rear brake adjuster ①

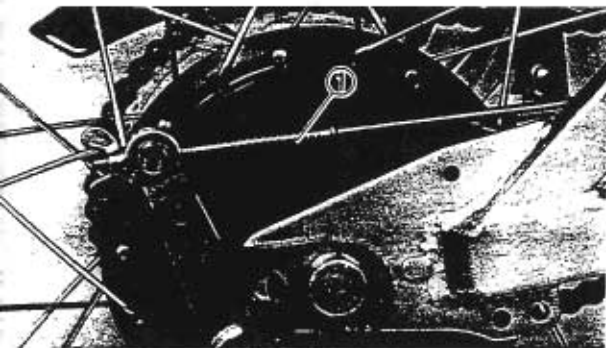

4. Remove:

- Cotter pin ①
- Nut (rear wheel axle) ②
- Washer ③
- Chain puller (right) ④



5. Remove:

- Rear wheel axle ①
- Chain puller (left) ②
- Rear wheel ③

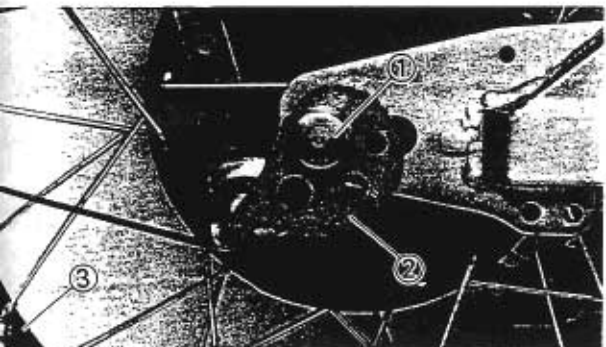
NOTE:

Push the rear wheel forward and disconnect the drive chain from the rear sprocket wheel.

6. Remove:

- Spacer collar ①



**INSPECTION**

When inspecting the rear wheel, refer to the "FRONT WHEEL—INSPECTION" section.

ASSEMBLY

When assembling the brake shoe plate, reverse the removal procedure.

Note the following points.

1. Install:
 - Brake camshaft

NOTE:

Apply the lithium soap base grease onto the brake camshaft and pin.

CAUTION:

After installing the brake camshaft, take off the excess grease.

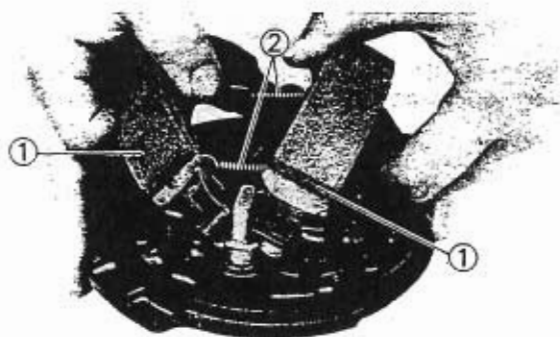

2. Install:
 - Brake shoe ①
 - Spring ②

CAUTION:

When installing the spring and brake shoe, take care not to damage the spring.

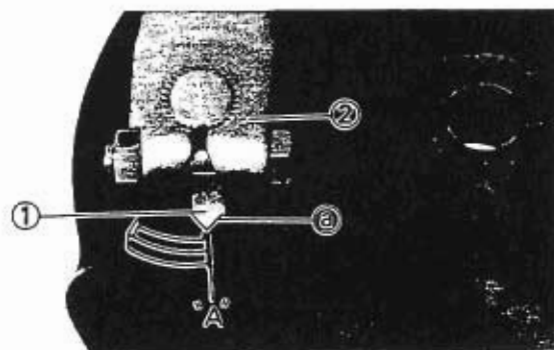

3. Install:
 - Wear indicator ①
 - Camshaft lever ②

NOTE:

Align the wear indicator projection (a) with "A" line as shown.



Bolt (camshaft lever):
8 Nm (0.8 m • kg, 5.8 ft • lb)



4. Install:
 - Plain washer
 - Brake cable

INSTALLATION

Reverse the "Removal" procedure.
Note the following points.

1. Lubricate:
 - Rear wheel axle
 - Bearings
 - Oil seals



Recommended lubricant:
Lithium soap base grease

2. Install:
 - Brake unit ①

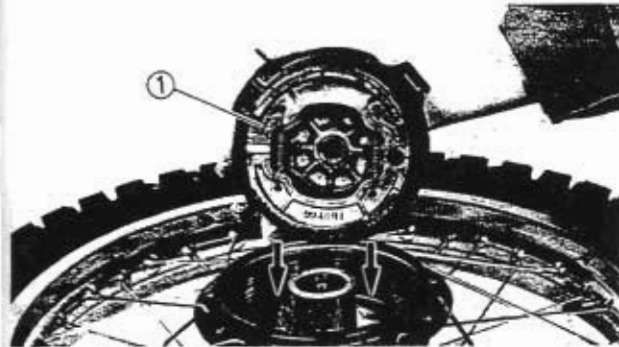

3. Install:
 - Rear wheel ①

NOTE:

Be sure the boss on the swingarm correctly engages with the locating slot on the brake shoe plate assembly.

4. Adjust:
 - Drive chain slack



Drive chain slack:
35–40 mm (1.4–1.6 in)

Refer to the "DRIVE CHAIN ADJUSTMENT" section in the CHAPTER 3.

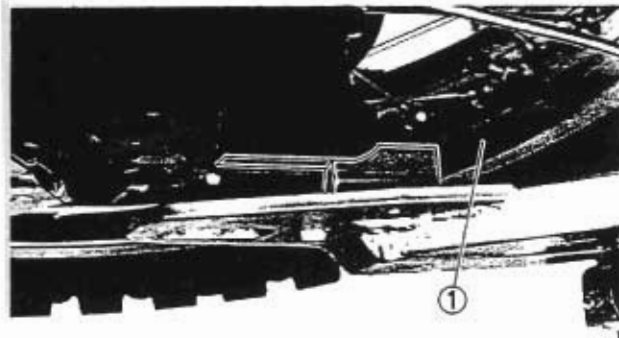

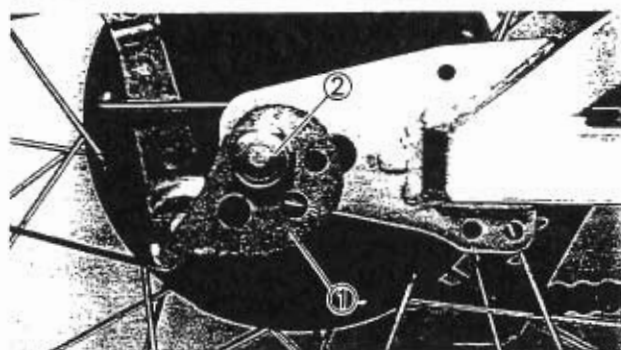

5. Install:

- Chain puller ①
- Bolt (rear wheel axle) ②

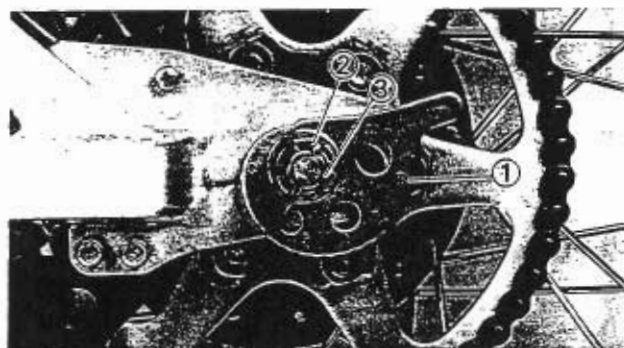

6. Install:

- Chain puller ①
- Washer ②
- Nut (rear wheel axle) ③

7. Tighten:

- Nut (rear wheel axle)



Nut (rear wheel axle):
85 Nm (8.5 m • kg, 61 ft • lb)

NOTE: _____

Do not loosen the axle nut after torque tightening.

If the axle nut groove is not aligned with the wheel shaft cotter pin hole, align groove to hole by tightening up on the axle nut.

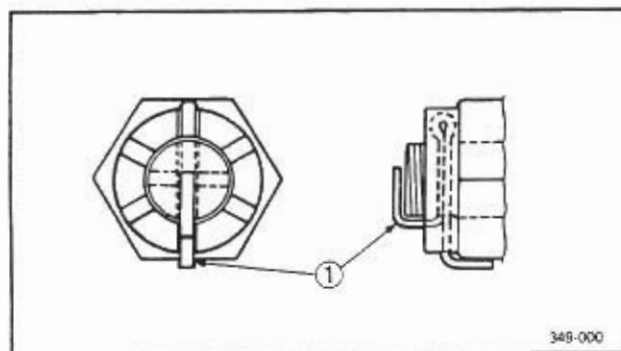

8. Install:

- Cotter pin

NOTE: _____

Bend the ends of the cotter pin.

WARNING _____

Always use a new cotter pin on the axle nut.



9. Adjust:

- Brake pedal free play

Refer to "REAR BRAKE ADJUSTMENT" section in the CHAPTER 3.



Brake pedal free play:

20~30 mm (0.79~1.18 in)

STATIC WHEEL BALANCE ADJUSTMENT**NOTE:** _____

- After replacing the tire and/or rim, wheel balance should be adjusted.
- Adjust the wheel balance with brake disc and hub installed.

1. Adjust:

- Wheel balance

Refer to the "FRONT WHEEL—STATIC WHEEL BALANCE ADJUSTMENT" section.



FRONT FORK

- | | |
|-------------------|-------------------|
| ① Cap | ⑨ Oil lock pieces |
| ② Cap bolt | ⑩ Dust seal |
| ③ O-ring | ⑪ Circlip |
| ④ Spacer | ⑫ Oil seal |
| ⑤ Spring seat | ⑬ Slide bush |
| ⑥ Fork spring | ⑭ Outer fork tube |
| ⑦ Inner fork tube | ⑮ Fork boot |
| ⑧ Damper rod | |

FORK OIL (EACH):

CAPACITY:

254 cm³ (8.94 Imp oz, 8.59 US oz)

GRADE:

A FORK OIL 10W OR EQUIVALENT

OIL LEVEL:

467 mm (18.39 in)

Below the top of inner tube fully extended without fork spring

FORK SPRING:

B MINIMUM FREE LENGTH:

428.5 mm (16.87 in)

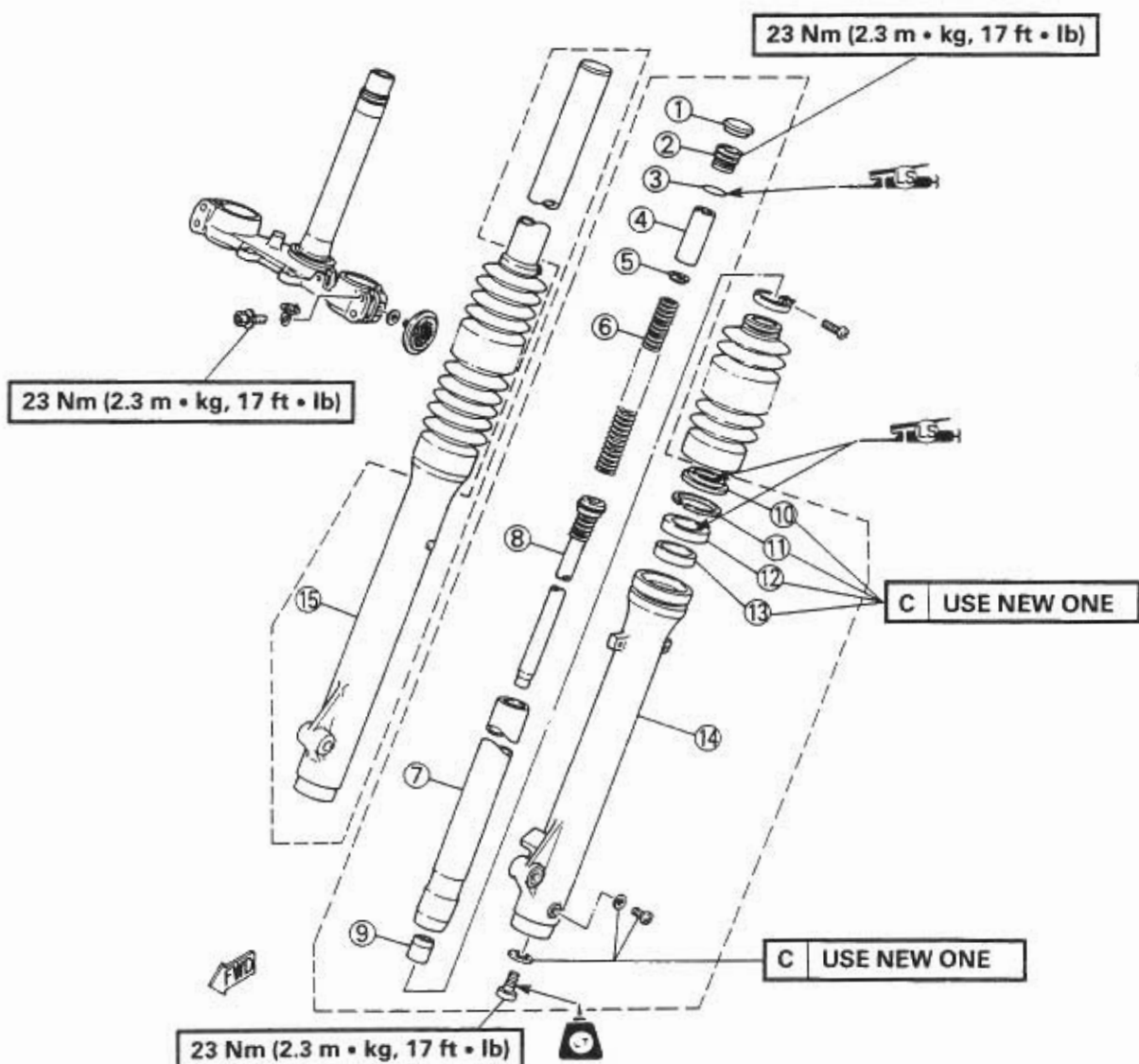



REMOVAL

⚠ WARNING

Securely support the motorcycle so there is no danger of it falling over.

1. Place the motorcycle on a level place.
2. Elevate the front wheel by placing a suitable stand under the engine.
3. Remove:
 - Front wheel
 Refer to the "FRONT WHEEL— REMOVAL" section.

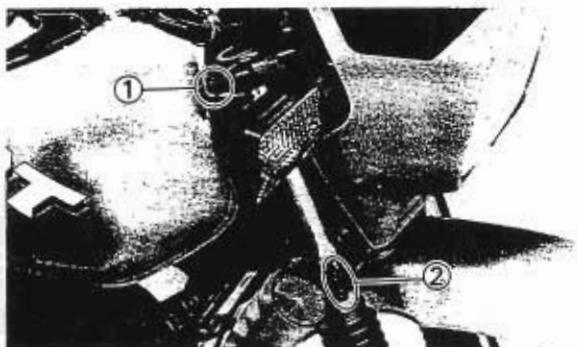

4. Loosen:
 - Pinch bolts (handlebar crown) ①
 - Pinch bolts (lower bracket) ②

⚠ WARNING

Support the fork before loosening the pinch bolts.

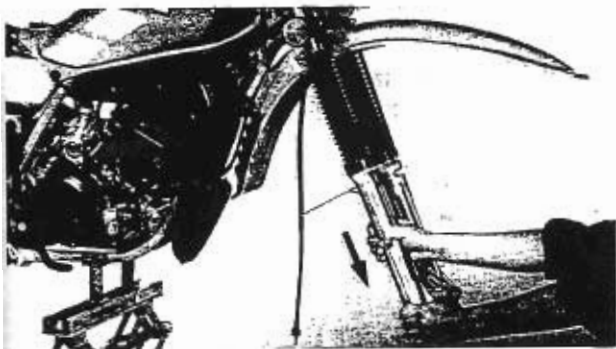

5. Remove:
 - Front fork

DISASSEMBLY

1. Remove:
 - Clamps ①
 - Fork boot ②

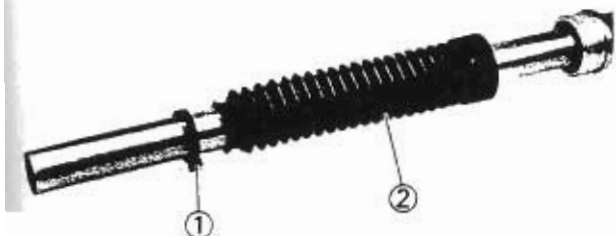

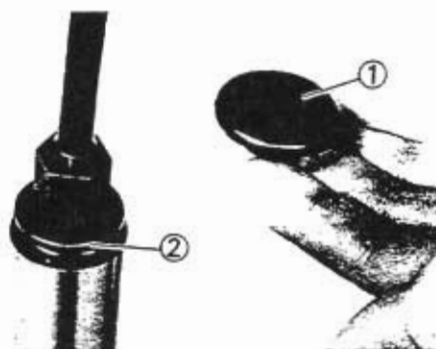

2. Remove:

- Cap ①
- Cap bolt ②



T-handle:

90890-01326

Holder:

90890-04084

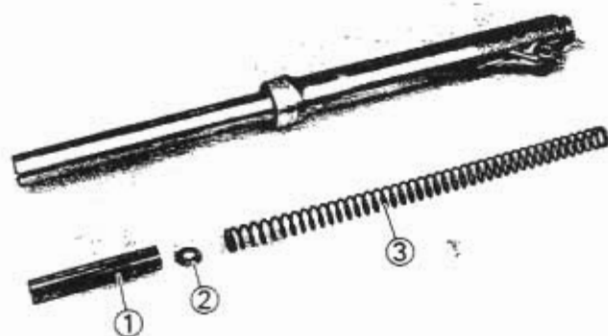

3. Remove:

- Spacer ①
- Spring seat ②
- Fork spring ③

4. Drain:

- Fork oil

5. Remove:

- Bolt (damper rod) ①
- Copper washer ②

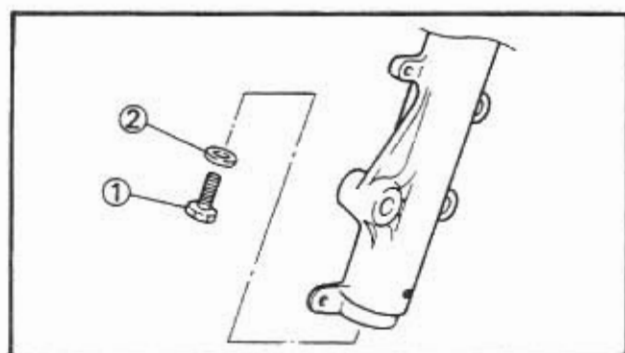

NOTE:

Hold the damper rod to loosen the bolt (damper rod) by the T-handle ① and holder ②.

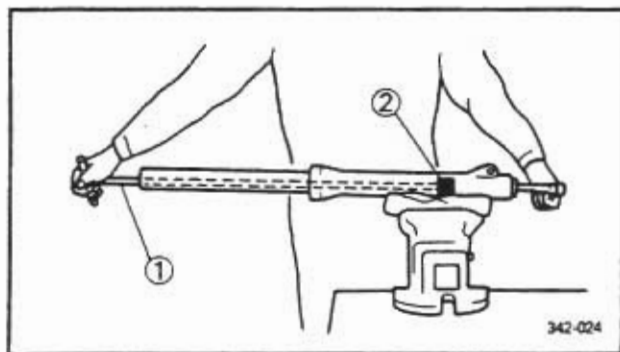

T-Handle:

90890-01326

Holder:

90890-04084

6. Remove:

- Damper rod ①
- Rebound spring ②
- (Out of inner fork tube ③)

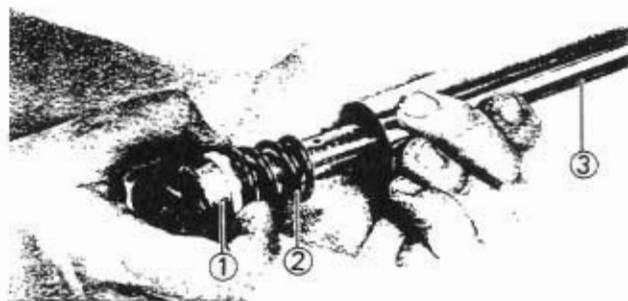

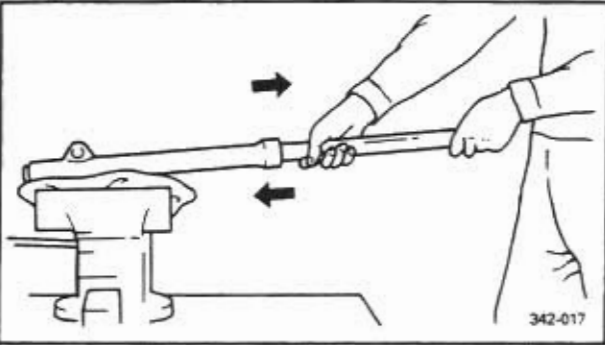

7. Remove:
- Inner fork tube

Removal steps:

- Hold the fork leg horizontally.
- Clamp the caliper mounting boss of the outer tube securely in a vise with soft jaws.
- Pull out the inner fork tube from the outer tube by forcefully, but carefully, with drawing the inner tube.

CAUTION:

- Excessive force will damage the oil seal and/or the bushes. Damage oil seal and bushing must be replaced.
- Avoid bottoming the inner tube in the outer tube during the above procedure, as the oil lock piece will be damaged.

8. Remove:
- Dust seal



9. Remove:
- Clip ①
 - Oil seal ②
 - Oil lock piece ③

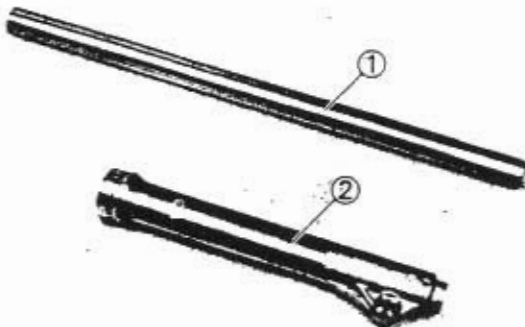
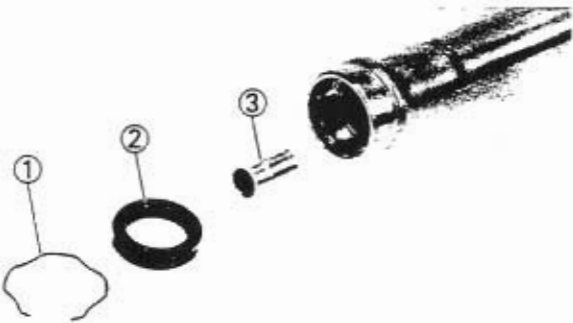

INSPECTION

1. Inspect:
- Inner fork tube ①
 - Outer fork tube ②
- Scratches/Bends/Damage→Replace.

⚠ WARNING

Do not attempt to straighten a bent inner fork tube as this may dangerously weaken the tube.

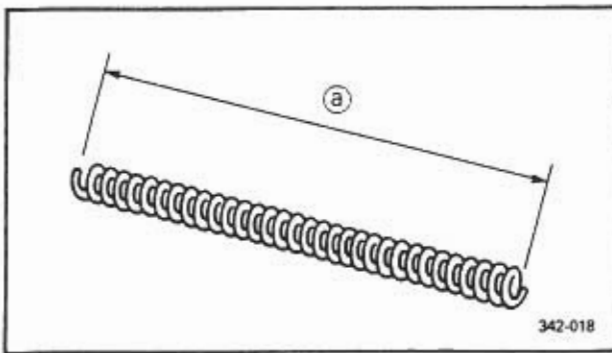

2. Measure:

- Fork spring
- Over specified limit→Replace.



Fork spring free length (limit):
428.5 mm (16.87 in)

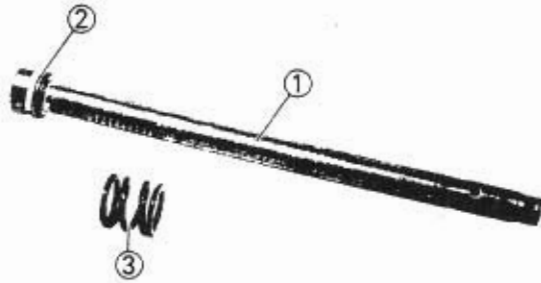

3. Inspect:

- Damper rod ①
- Ring ②
- Round spring ③
- Wear/Damage→Replace.
- Contamination→Blow out all passages with compressed air.

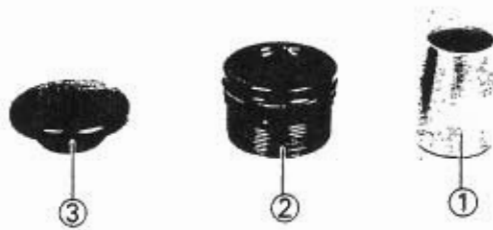

4. Inspect:

- Oil lock piece ①
- O-ring (cap bolt) ②
- Cap ③
- Wear/Damage→Replace.

ASSEMBLY

Reverse the "DISASSEMBLY" procedure.
Note the following points.

NOTE:

- In front fork reassembly, be sure to use following new parts.
 - * Oil seal
 - * Dust seal
- Make sure that all components are clean before reassembly.

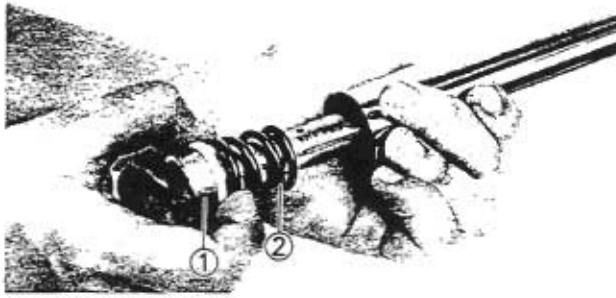

1. Install:
 - Damper rod (1)
 - Rebound spring (2)

CAUTION:

Allow the damper rod to slide slowly down the inner fork tube until it protrudes from the bottom, being careful not to damage the inner fork tube.

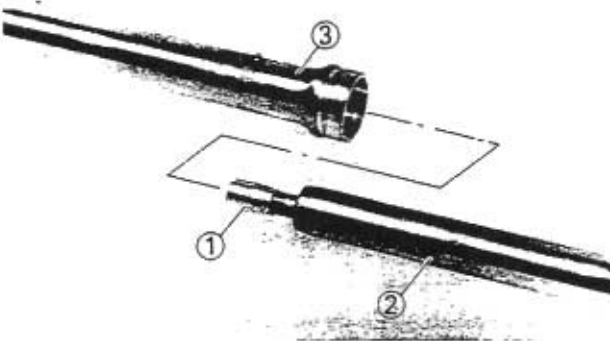

2. Install:
 - Oil lock piece (1)
(to damper rod)
3. Lubricate:
 - Inner fork tube (outer surface) (2)



Recommended lubricant:
Fork oil 10W or equivalent

- ③ Outer fork tube
4. Tighten:
 - Bolt (damper rod)



Bolt (damper rod):
23 Nm (2.3 m•kg, 17 ft•lb)
LOCTITE®

NOTE:

Tighten the bolt (damper rod) while holding the damper rod with the T-handle (1) and holder (2).

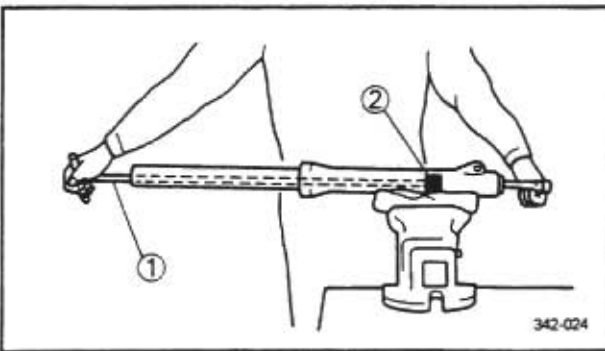

T-handle:
90890-01326
Holder:
90890-04084

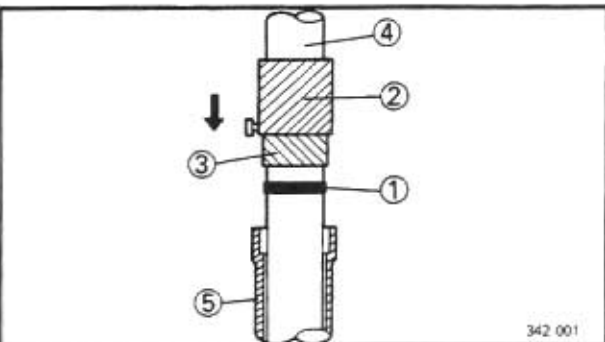

5. Install:
 - Oil seal (1)

Use the fork seal driver weight (2) and adapter (3).



Fork seal driver weight:
90890-01367
Adapter:
90890-01372

- ④ Inner fork tube
- ⑤ Outer fork tube

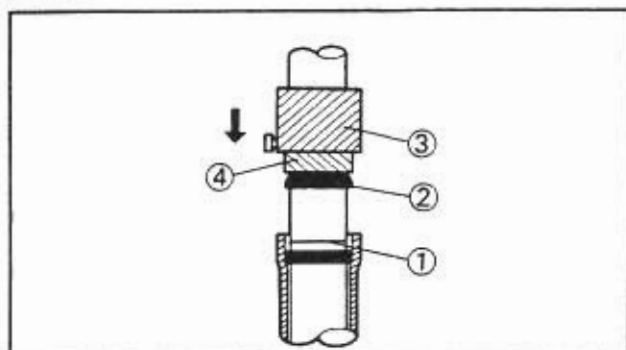

6. Install:

- Clip ①

7. Install:

- Dust seal ②

Use the fork seal driver weight ③ and adapter ④.



Fork seal driver weight:

90890-01367

Adapter:

90890-01372

NOTE:

Before installing the oil seal, apply the lithium soap base grease onto the oil seal lips.

CAUTION:

Be sure that the oil seal numbered side face upward.

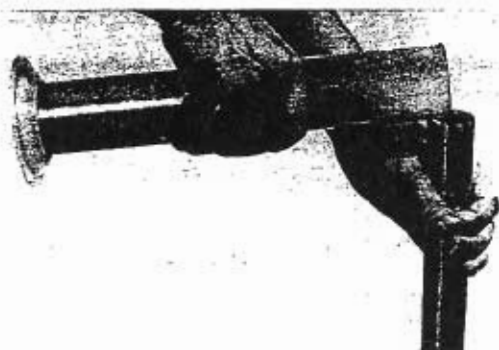

8. Fill:

- Front fork



Each fork:

254 cm³

(8.94 Imp oz, 8.59 US oz)

Fork oil 10W or equivalent
after filling, slowly pump the fork
up and down to distribute oil.



Oil level: ①

467 mm (18.39 in)

from the top of inner fork tube
fully extended without spring.

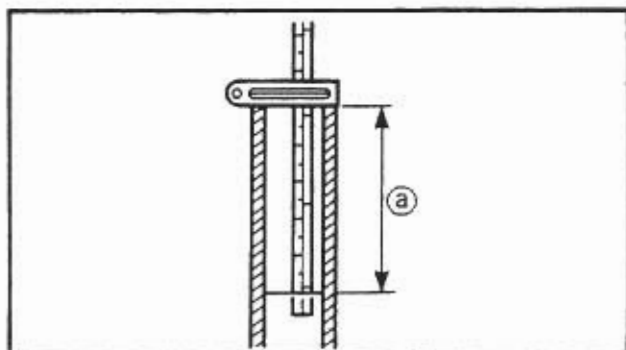

NOTE:

Place the front fork on upright position.

9. Install:

- Fork spring ①
- Spring seat ②
- Spacer collar ③

NOTE:

Place the flat surface of spring seat on upright position when installing the spring seat.

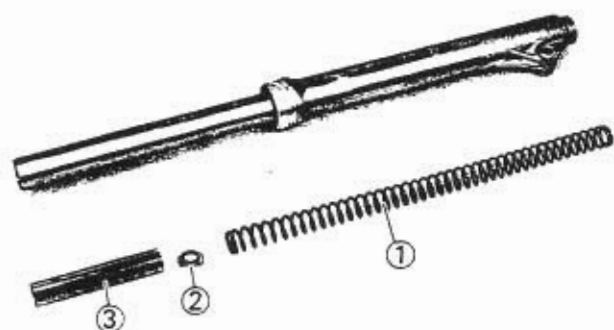



10. Install:

- Cap bolt ①

NOTE: _____

- Before installing the cap bolt, apply the grease to the O-ring.
- Temporarily tighten the cap bolt.

INSTALLATION

Reverse the "REMOVAL" procedure.

Note the following points.

1. Install:

- Front forks
- Temporarily tighten the pinch bolts.

NOTE: _____

Be sure the inner fork tube end is flush with the top of the handle crown.

2. Tighten:

- Pinch bolts ① (lower bracket)
- Pinch bolts ② (handle crown)
- Cap bolt ③



Pinch bolts (lower bracket):
23 Nm (2.3 m • kg, 17 ft • lb)

Pinch bolts (handle crown):
23 Nm (2.3 m • kg, 17 ft • lb)

Cap bolt:
23 Nm (2.3 m • kg, 17 ft • lb)

3. Install:

- Cap (cap bolt)
- Front wheel ①
- Brake cable ②
- Speedometer cable ③

Refer to the "FRONT WHEEL" section.



Wheel axle:
39 Nm (3.9 m • kg, 28 ft • lb)

WARNING

Make sure that the brake cable is routed properly.

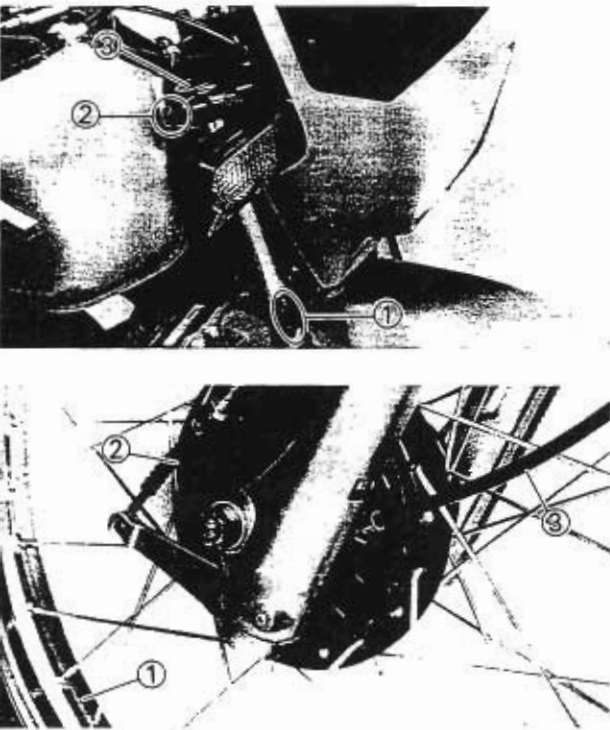

STEERING HEAD AND HANDLEBARS

- | | |
|----------------------------|------------------------------------|
| ① Handlebar | ⑧ Bearing race (upper) |
| ② Handlebar grip (right) | ⑨ Bearing race (lower) |
| ③ Handlebar grip (left) | ⑩ Ball |
| ④ Handlebar holder (upper) | ⑪ Steering seal |
| ⑤ Handlebar crown | ⑫ Cable holder (speedometer cable) |
| ⑥ Ring nut | ⑬ Headlight stay |
| ⑦ Cover | |

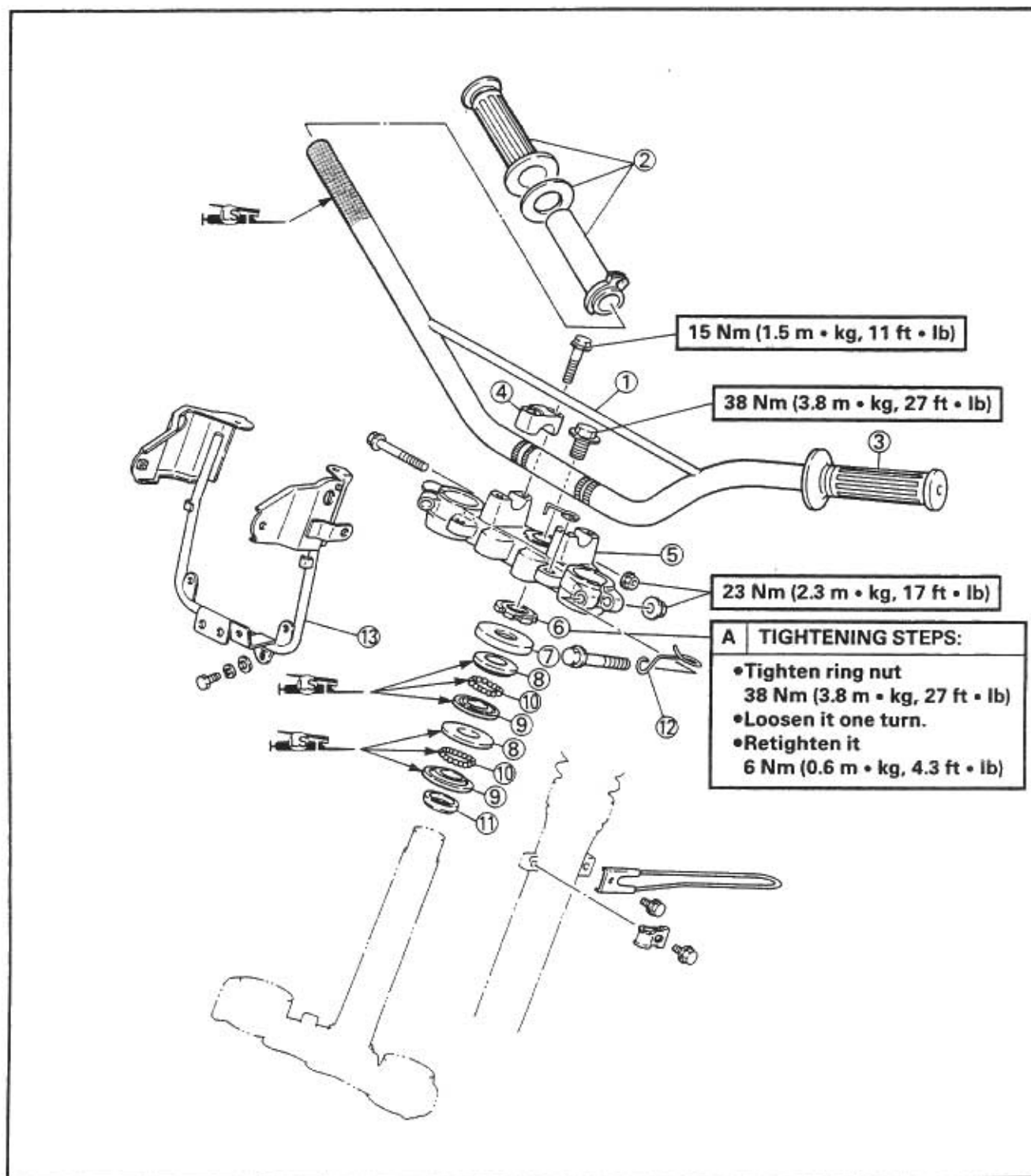



REMOVAL

⚠ WARNING

Securely support the motorcycle so there is no danger of it falling over.

1. Remove:

- Front wheel
Refer to the "FRONT WHEEL—REMOVAL" section.
- Front fork
Refer to the "FRONT FORK—REMOVAL" section.

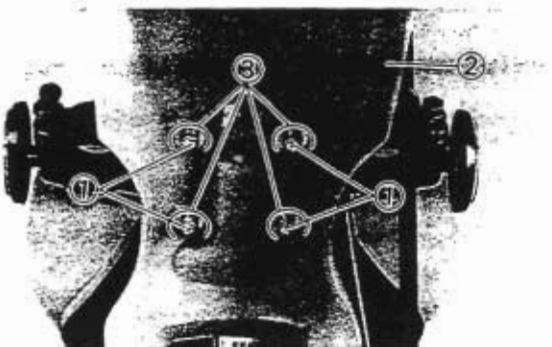

2. Remove:

- Bolts ① (front fender)
- Front fender ②
- Washers ③



3. Remove:

- Headlight cover ①

4. Remove:

- Headlight lens unit ①

5. Disconnect:

- Headlight lead
- Auxiliary light lead



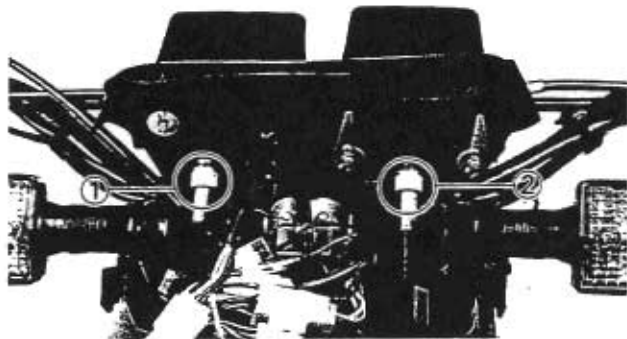

- 6. Disconnect:
 - Tachometer cable ①
 - Speedometer cable ②

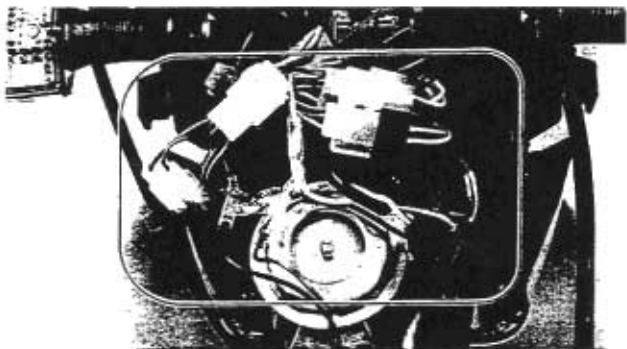

- 7. Disconnect:
 - Meter leads
 - Handlebar switch leads
 - Main switch leads
 - Flasher relay leads

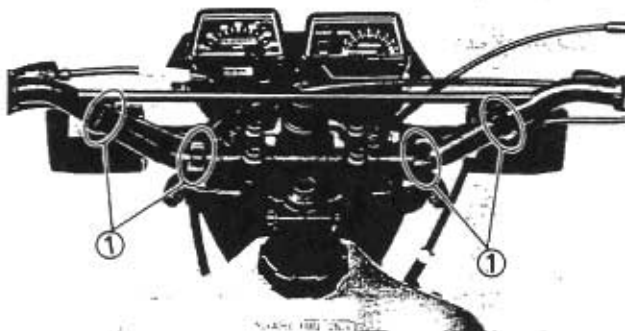

- 8. Remove:
 - Bands ①

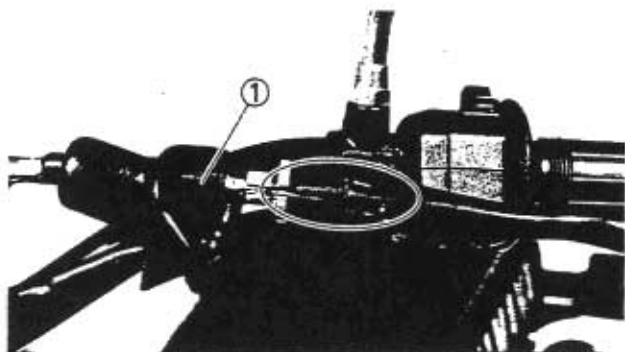

- 9. Disconnect:
 - Clutch cable ①
(from clutch cable pivot)

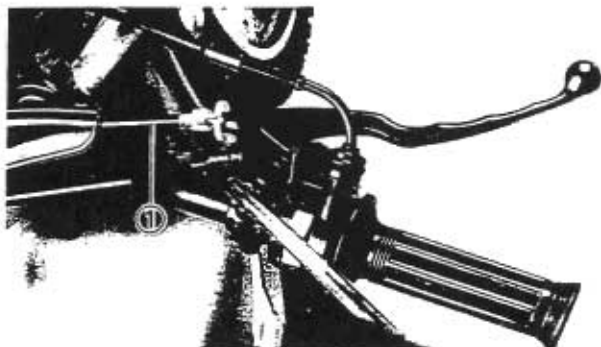

- 10. Disconnect:
 - Front brake cable ①
(from brake cable pivot)



11. Remove:
 • Meter assembly ①

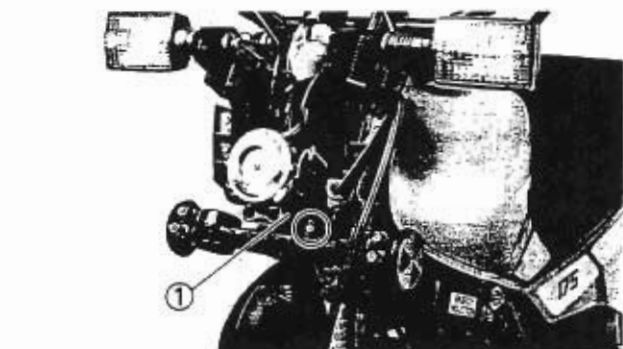

12. Remove:
 • Headlight stay ①

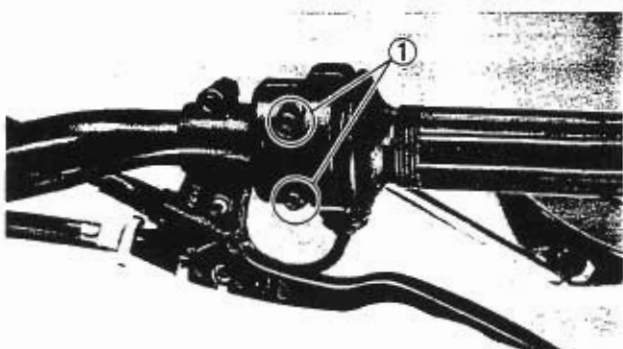

13. Loosen:
 • Screws (throttle cable housing) ①



14. Remove:
 • Throttle cable ①
 • Throttle grip ②

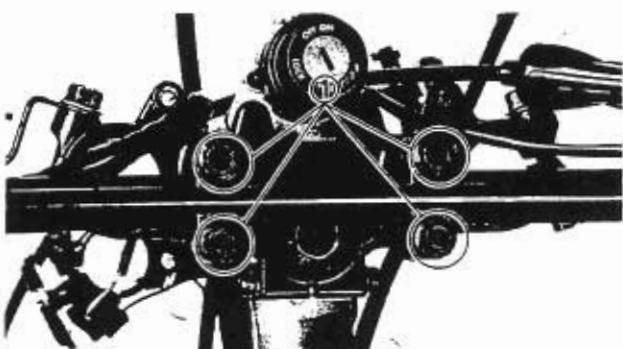

15. Remove:
 • Handlebar holders ①
 • Handlebar



16. Remove:

- Flange bolt (steering stem) ①
- Pinch bolt (steering stem) ②
- Handlebar crown ③

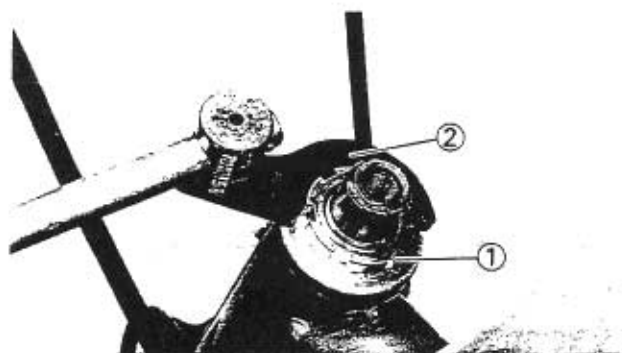

17. Remove:

- Ring nut (lower) ①
- Use the ring nut wrench ②.



Ring nut wrench:
90890-01403

⚠ WARNING

Support the steering shaft so that it may not fall down.

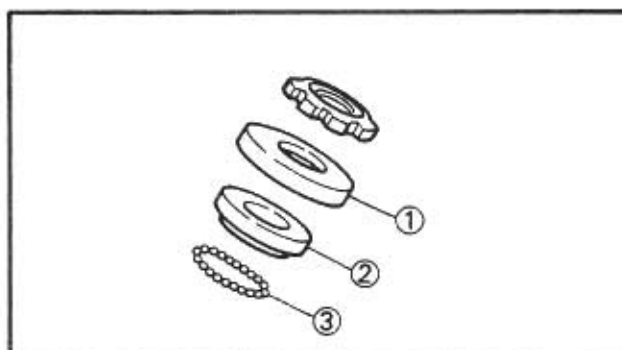

18. Remove:

- Bearing cover ①
- Ball race (top—upper) ②
- Ball bearing ③ (22 pcs)

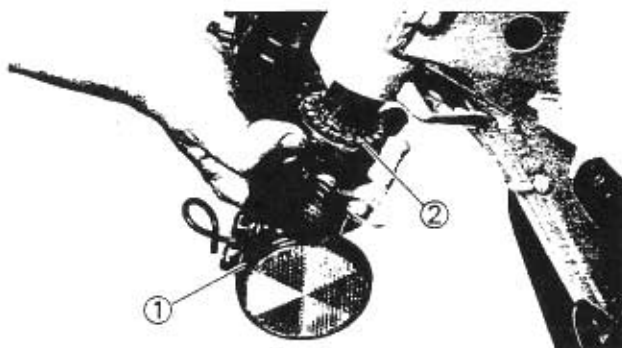

19. Remove:

- Lower bracket ①
- Ball bearing ② (19 pcs)

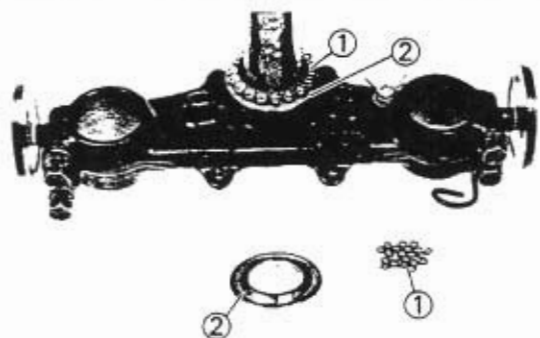

INSPECTION

1. Wash the bearing and bearing races with a solvent.
2. Inspect:
 - Bearings ①
 - Bearing races ②
 Pitting/Damage→Replace.

Bearing race replacement steps:

- Remove the bearing races on the head pipe using long rod ① and the hammer as shown.
- Remove the bearing race on the under bracket using the floor chisel ② and the hammer as shown.
- Install the new dust seal and races.

NOTE:

- Always replace bearings and races as a set.
- Replace the dust seal whenever a steering head disassembled.

CAUTION:

If the bearing race is fitted not squarely, the head pipe could be damaged.

3. Inspect:

- Handlebar crown ①
 - Under bracket ② (with steering stem)
- Cracks/Bends/Damage→Replace.

4. Inspect:

- Handlebar
- Bends/Cracks/Damage→Replace.

⚠ WARNING

Do not attempt to straighten a bent handlebar as this may dangerously weaken the handlebar.

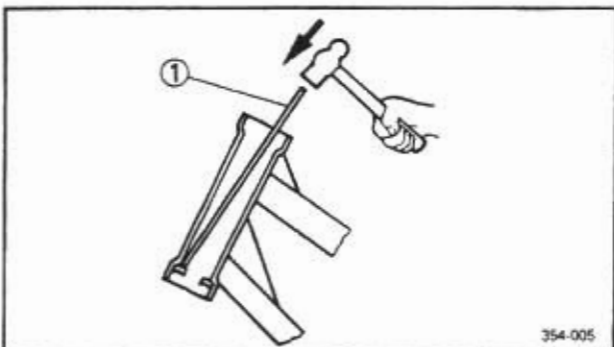

354-005

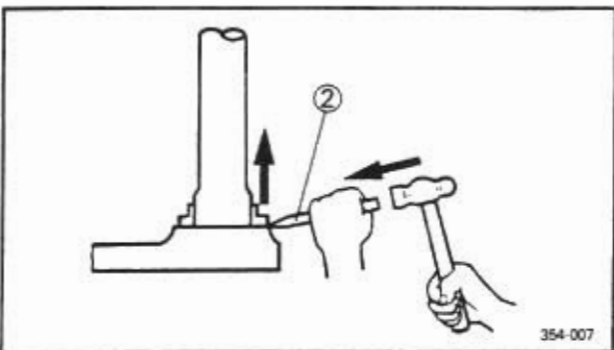

354-007

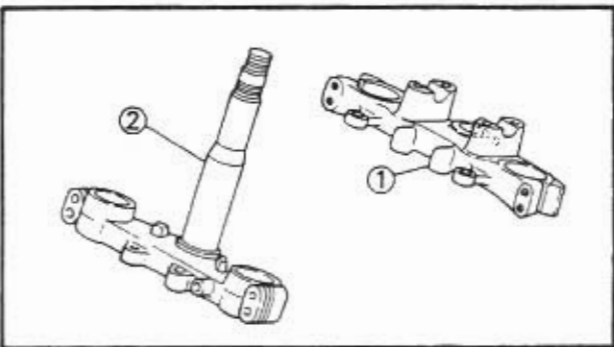

Replacement steps:

- Remove the handlebar grip and lever holder.
- Install the lever holder to a new handlebar.
- Apply a light coat of an adhesive for rubber on the left handlebar end.
- Install the handlebar grip.

NOTE: _____

Wipe off excess adhesive with a clean rag.

WARNING

Leave the handlebar intact until the adhesive becomes dry enough to make the grip and handlebar stuck securely.

INSTALLATION

Reverse the "REMOVAL" procedure.

Note the following points.

1. Lubricate:
 - Bearings (upper and lower)
 - Bearing races

| | |
|---|--|
|  | Recommended lubricant: Wheel bearing grease |
|---|--|

2. Install:
 - Ball bearings

NOTE: _____

Make sure the balls are of the same size and the quantity is correct.

Upper Ball size 3/16 in

Quantity 22 pcs

Lower Ball size 1/4 in

Quantity 19 pcs

3. Install:
 - Steering shaft

CAUTION: _____

Hold the steering shaft until it is secured.

- Hose clamp

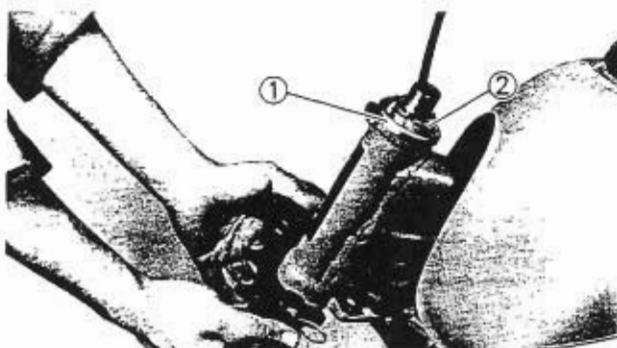
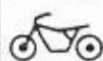

4. Install:
- Ball races (upper and lower)
 - Bearing cover ①
 - Ring nut ②

CAUTION: _____

Hold the steering stem until it is secured.

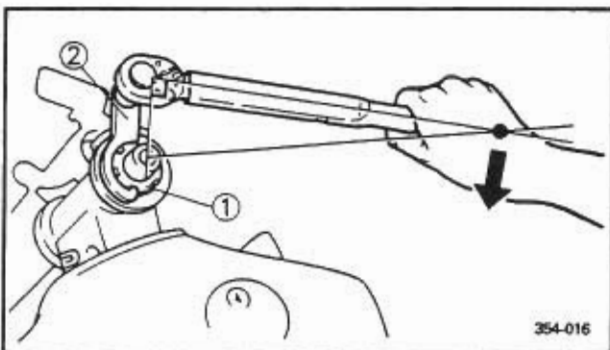

5. Tighten:

- Ring nut ①

Tightening steps:

NOTE: _____

Set the torque wrench ② to the ring nut wrench so that they form a right angle.

- Install the ring nut ①.
- Tighten the ring nut using the ring nut wrench ②.



Ring nut wrench:
90890-01403



Ring nut (initial tightening):
38 Nm (3.8 m•kg, 27 ft•lb)

- Loosen the ring nut completely and retighten it to specification.

⚠ WARNING _____

Do not over tightening.



Ring nut (final tightening):
6 Nm (0.6 m•kg, 4.3 ft•lb)

- Check the steering stem by turning lock to lock. If there is any binding, remove the steering stem assembly and inspect the steering bearings.

6. Install:

- Handlebar crown ①
- Flange bolt (steering stem) ②
- Pinch bolt (steering stem) ③

NOTE: _____

Temporarily tighten the flange bolt and pinch bolt.

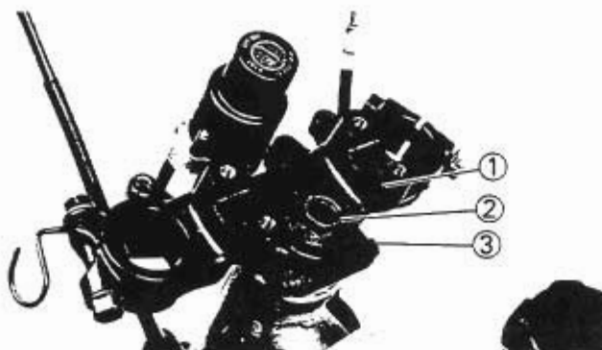

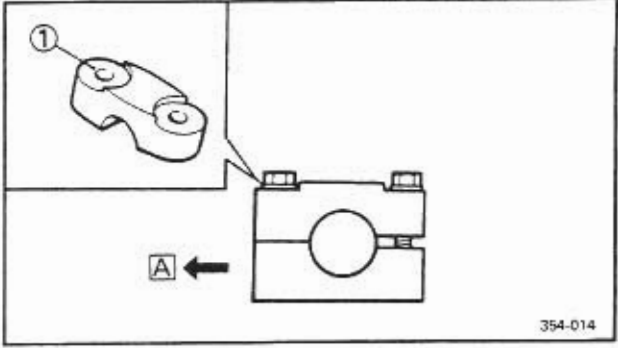

354-014

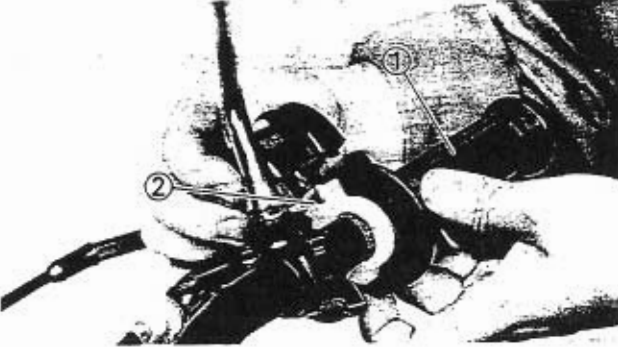
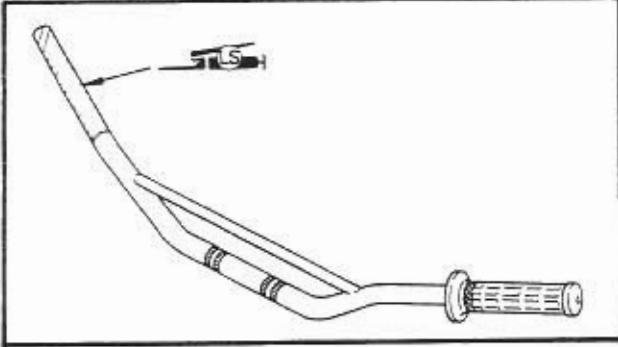

7. Install:
- Handlebar
 - Handlebar holders

 **Bolt (handlebar holder):**
15 Nm (1.5 m•kg, 11 ft•lb)

NOTE:

- Before installing the handlebar onto the handle crown, apply a light coat of lithium soap base grease onto the handlebar end and install the throttle housing to the handlebar.
- The upper handlebar holder should be installed with the punched mark ① forward **A**.

CAUTION:

First tighten the bolts on the front side of the handlebar holder, and then tighten the bolts on the rear side.

8. Install:
- Throttle grip ①
 - Throttle cable ②

WARNING

- Provide a clearance of 1 mm (0.04 in) between the throttle grip and handlebar end. Otherwise, the grip may not move.
- Check the throttle grip for smooth action.

NOTE:

Before installing the handlebar grip (right), apply a light coat of lithium soap base grease onto the handlebar end.

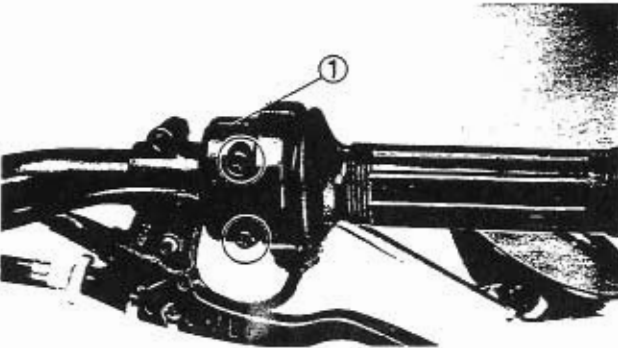

9. Install:
- Lever holder (right) ①

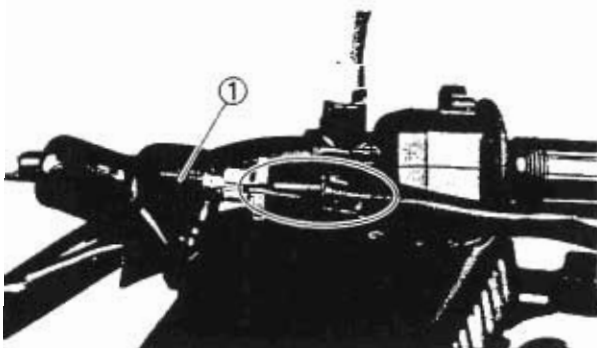

10. Install:

- Clutch cable ①

NOTE: _____

Apply a light coat of lithium soap base grease onto the clutch cable end.

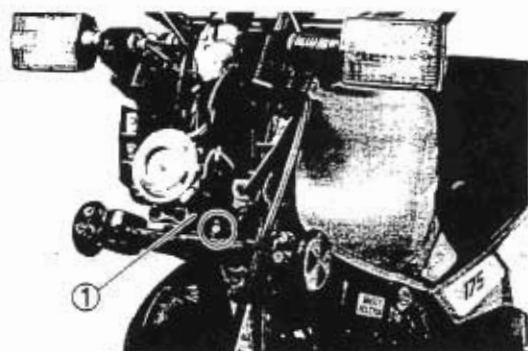

11. Install:

- Headlight stay ①



Bolt (headlight stay):

7 Nm (0.7 m•kg, 5.1 ft•lb)



12. Install:

- Meter assembly ①



Bolt (meter assembly):

7 Nm (0.7 m•kg, 5.1 ft•lb)



13. Install:

- Front fork

Refer to the "FRONT FORK—INSTALLATION" section.



Pinch bolt (under bracket):

23 Nm (2.3 m•kg, 17 ft•lb)

NOTE: _____

In this stage, temporarily tighten the pinch bolts (handlebar crown).

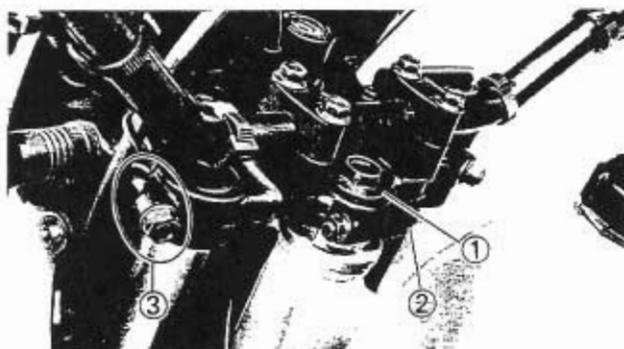

14. Tighten:

- Flange bolt (steering stem) ①
- Pinch bolt (steering stem) ②
- Pinch bolt (handlebar crown) ③

**Flange bolt (steering stem):**

54 Nm (5.4 m•kg, 39 ft•lb)

Pinch bolt (steering stem):

23 Nm (2.3 m•kg, 17 ft•lb)

Pinch bolt (handlebar crown):

23 Nm (2.3 m•kg, 17 ft•lb)

NOTE:

- Be sure the inner fork tube end is flush with the top of the handlebar crown.
- Install the brake hose guide to the left side only.
- On the left side, install the flasher light having a chocolate color lead. Next, install the other flasher light with a dark green color lead.

15. Install:

- Front wheel

Refer to the "FRONT WHEEL—INSTALLATION" section.

**Front wheel axle:**

39 Nm (3.9 m•kg, 28 ft•lb)

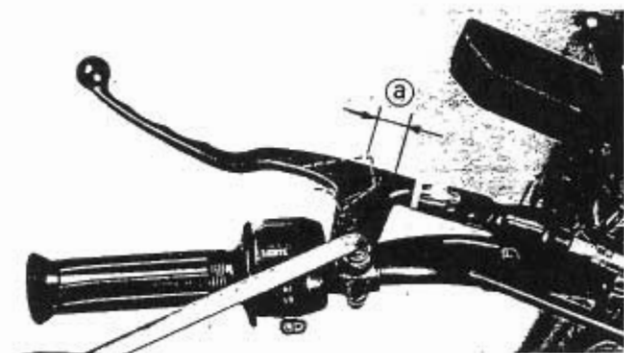

16. Adjust:

- Clutch cable free play (a)

Refer to the "CLUTCH ADJUSTMENT" section in the CHAPTER 3.

**Free play:**

2~3 mm (0.08~0.12 in)

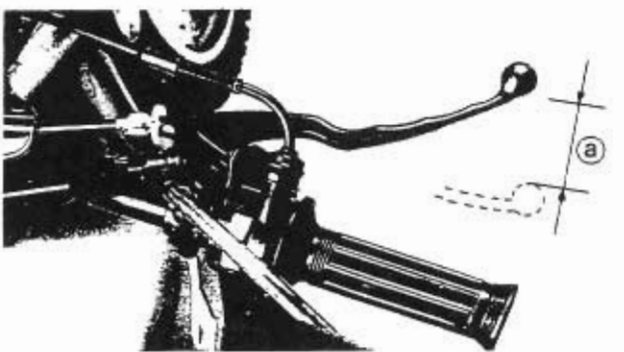

17. Adjust:

- Front brake cable free play (a)

Refer to the "FRONT BRAKE ADJUSTMENT" section in the CHAPTER 3.

**Free play:**

5~8 mm (0.20~0.32 in)

REAR SHOCK ABSORBER AND SWINGARM

- ① Rear shock absorber assembly
- ② Spring
- ③ Bush

A **SPRING PRELOAD (INSTALLED):**
STANDARD LENGTH:
 249 mm (9.96 in)
MINIMUM LENGTH:
 245 mm (9.80 in)
MAXIMUM LENGTH:
 253 mm (10.12 in)

32 Nm (3.2 m • kg, 23 ft • lb)

B USE NEW ONE

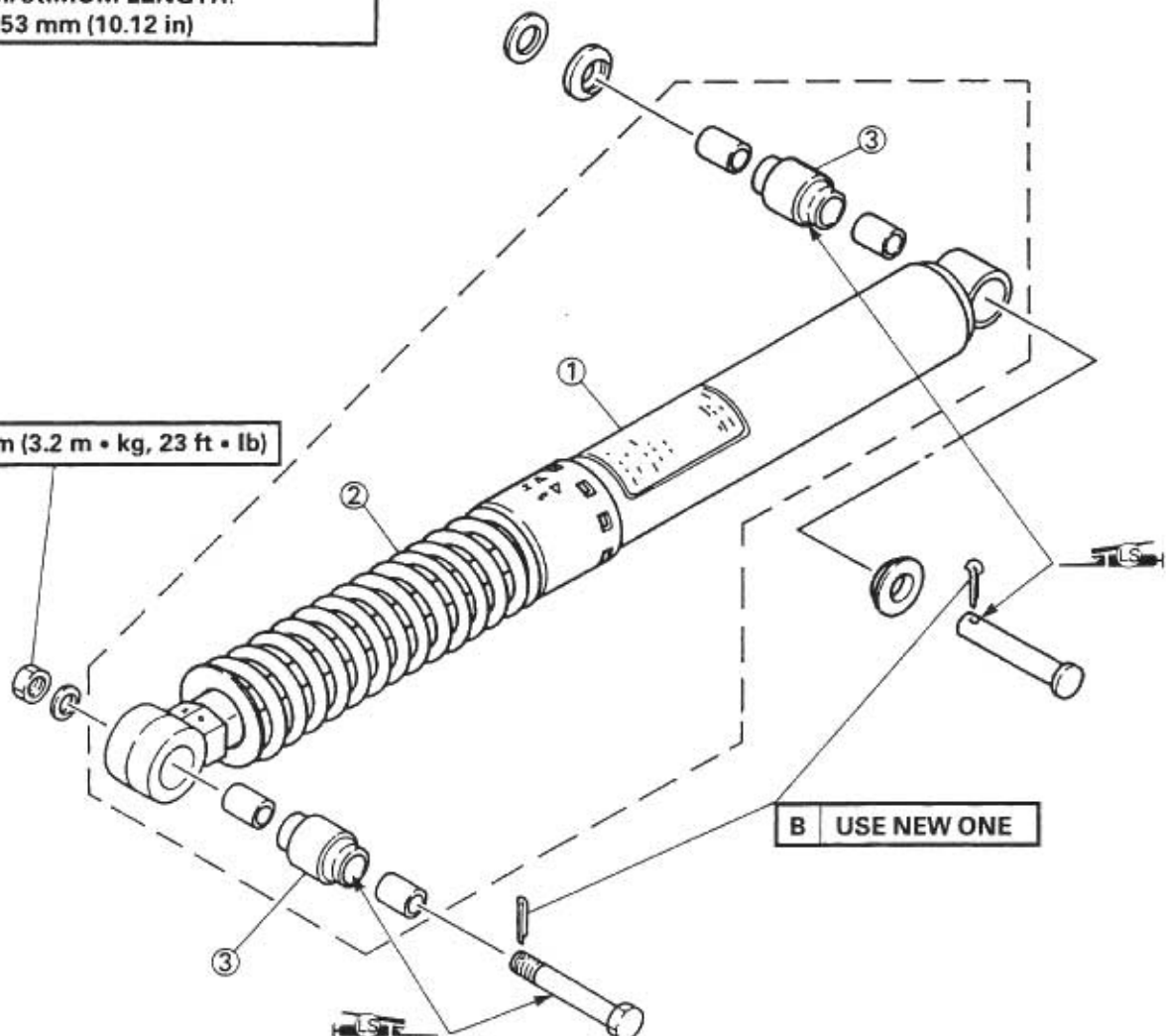



- ① Swingarm
- ② Chain case
- ③ Chain guard
- ④ Guard seal
- ⑤ Shim
- ⑥ Collar (outer)
- ⑦ Collar (inner)
- ⑧ Tensioner arm

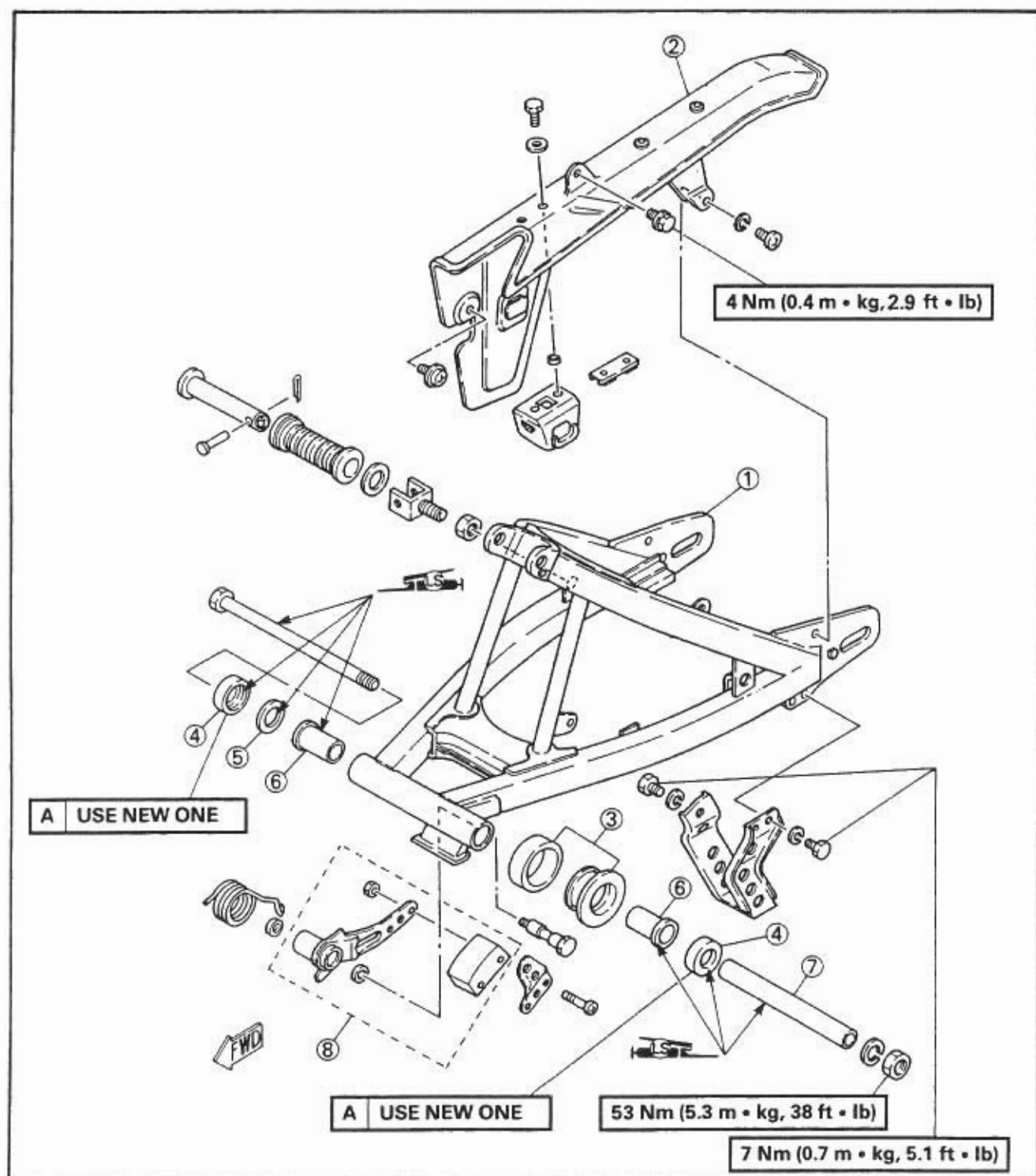



HANDLING NOTES

⚠ WARNING

This shock absorber contains highly compressed nitrogen gas. Read and understand the following information before handling the shock absorber. The manufacture cannot be held responsible for property damage or personal injury that may result from improper handling.

1. Do not tamper or attempt to open the cylinder assembly.
2. Do not subject shock absorber to an open flame or other high heat. This may cause the unit to explode due to excessive gas pressure.
3. Do not deform or damage are cylinder in any way. Cylinder damage will result in poor damping performance.

NOTES ON DISPOSAL

Shock absorber disposal steps:

- Gas pressure must be released before disposing of shock absorber. To do so, drill ① a 2~3 mm (0.08~0.12 in) hole through the cylinder wall at a point 15~20 mm (0.6~0.8 in) ② from the end of gas chamber.

⚠ WARNING

Wear eye protection to prevent eye damage from escaping gas and/or metal chips.

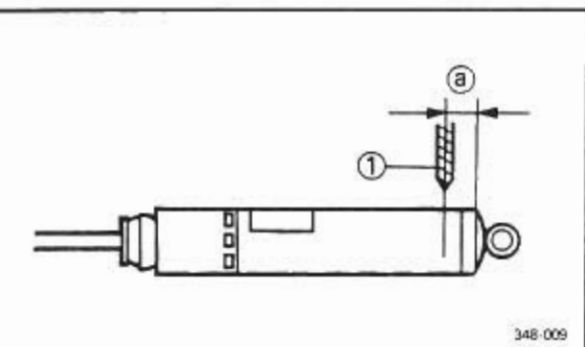

348-009

REMOVAL

Rear shock absorber

1. Place the motorcycle on a level place.
2. Elevate the rear wheel by placing a suitable stand under the engine.

⚠ WARNING

Securely support the motorcycle so there is no danger of it falling over.

- 3. Remove:
 - Side covers
 - Seat
 - Fuel tank

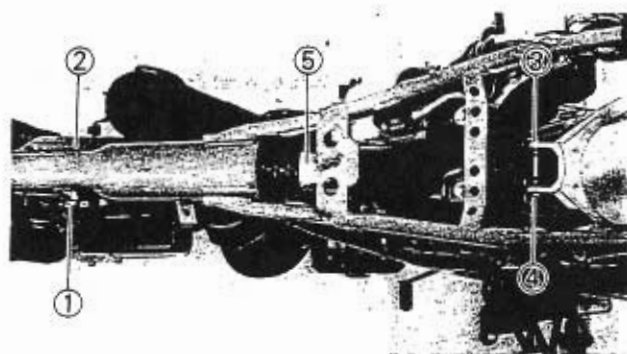

- 4. Remove:
 - Rear wheel
Refer to the "REAR WHEEL—REMOVAL" section.
 - Cotter pin ①
 - Bolt (shock absorber—upper) ②
 - Cotter pin ③
 - Stopper ④
 - Rear shock absorber ⑤

Swingarm

- 1. Place the motorcycle on a level place.
- 2. Elevate the rear wheel by placing a suitable stand under the engine.

⚠ WARNING

Securely support the motorcycle so there is no danger of it falling over.

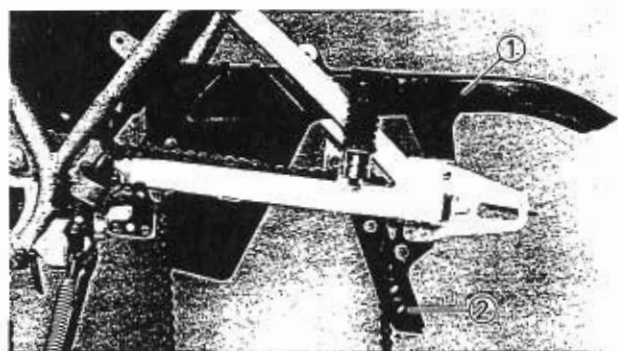

- 3. Remove:
 - Rear shock absorber
Refer to the "REAR SHOCK ABSORBER—REMOVAL" section.

- 4. Remove:
 - Chain case ①
 - Chain guide ②



- 5. Check:
 - Swingarm free play

Inspection steps:

- Check the tightening torque of the pivot shaft (swingarm) securing nut ①.

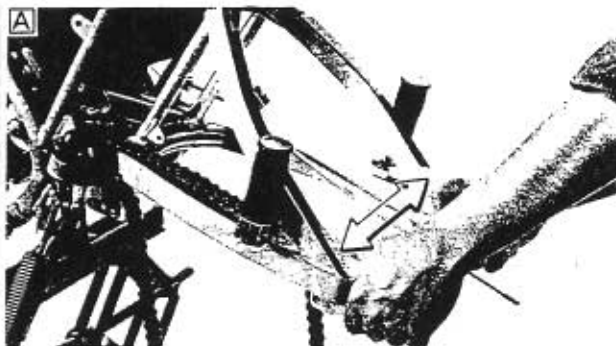

Nut (swingarm pivot shaft):
53 Nm (5.3 m • kg, 38 ft • lb)

- Check the swingarm side play **A** by moving it from side to side.

If side play noticeable, check the inner collar, bearing, washer and thrust cover.

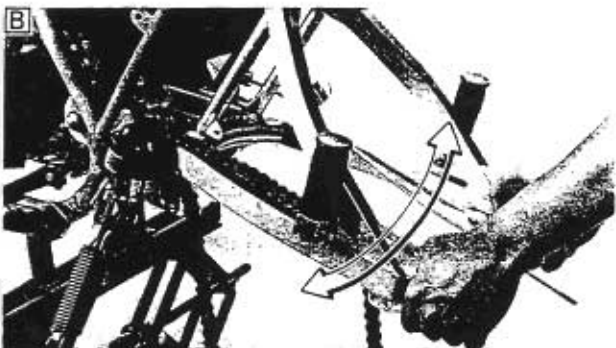

Side play (at end of swingarm):
1 mm (0.04 in)

- Check the swingarm vertical movement **B** by moving it up and down.

If vertical movement is tight, binding or rough, check the inner collar, bearing, washer and thrust cover.

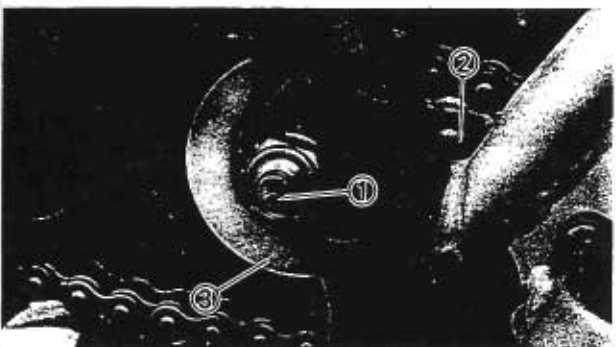

6. Remove:

- Pivot shaft **1**
- Swingarm **2**
- Guard seal **3**



7. Remove:

- Tensioner arm **1**

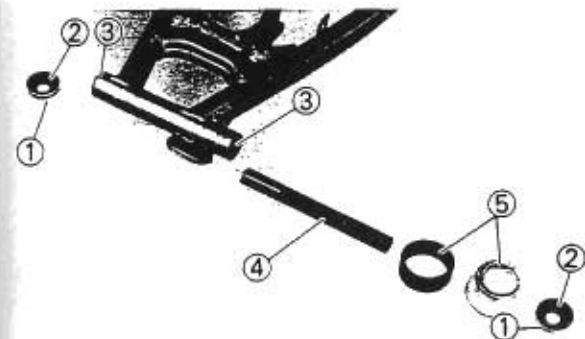

8. Remove:

- Guard seal **1**
- Shim **2**
- Collar (outer) **3**
- Collar (inner) **4**
- Chain guard **5**

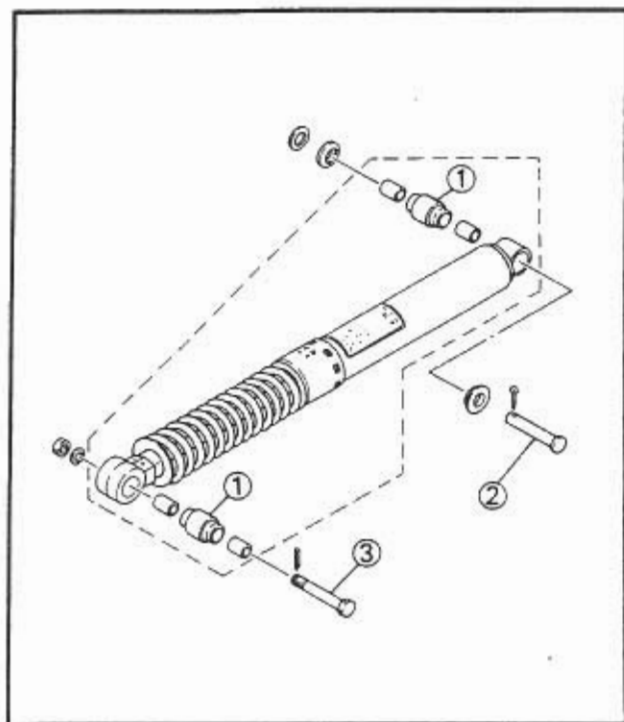
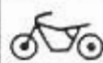

INSPECTION

Rear shock absorber

1. Inspect:

- Rear shock absorber rod
Bends/Damage→Replace the rear shock absorber assembly.
- Rear shock absorber
Oil leaks/Gas leaks→Replace the rear shock absorber assembly.
- Spring
Wear/Damage→Replace the rear shock absorber assembly.
- Bushings ①
- Pin ②
Wear/Damage→Replace.
- Bolts ③
Wear/Bends/Damage→Replace.

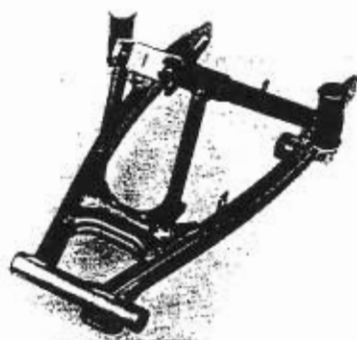

Swingarm

1. Inspect:

- Swingarm
Crack/Bend/Damage→Replace.

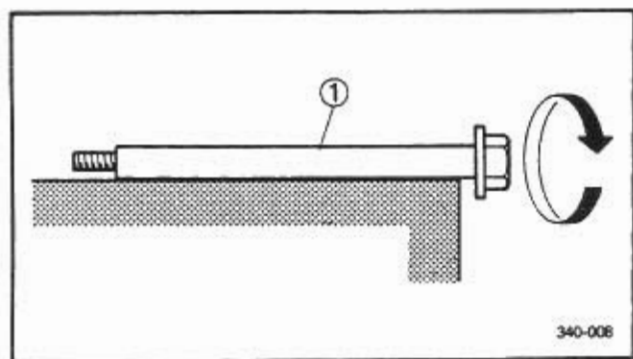

2. Inspect:

- Pivot shaft
Roll the axle on a flat surface.
Bends→Replace.

⚠ WARNING

Do not attempt to straighten a bent axle.

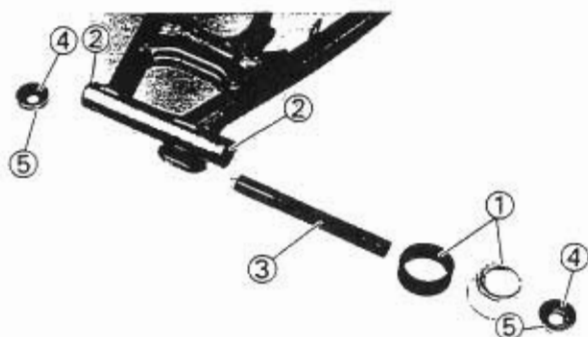

3. Wash the swingarm pivoting parts in a solvent.

4. Inspect:

- Guard seal ①
- Collar (outer) ②
- Collar (inner) ③
- Shim ④
- Guard seal ⑤
Wear/Damage→Replace.

NOTE: _____

When replacing the bearing and bush of swingarm pivot, install new bearing and bush as shown.

INSTALLATION

Swingarm

Reverse the "REMOVAL" procedure.

Note the following points.

1. Lubricate:
 - Outer collars
 - Inner collar
 - Thrust washers
 - Guard seal
 - Pivot shaft

| | |
|--|---|
|  | <p>Recommended lubricant: Lithium soap base grease</p> |
|--|---|

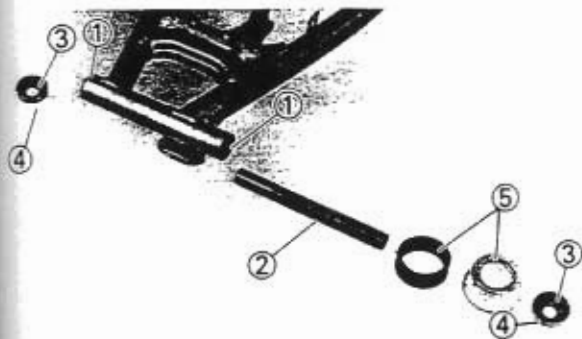

2. Install:
 - Outer collars ①
 - Inner collar ②
 - Shim ③
 - Guard seal ④
 - Chain guard ⑤
 - Pivot shaft
 - Nut

3. Tighten:
 - Nut (pivot shaft) ①

| | |
|---|---|
|  | <p>Nut (pivot shaft): 53 Nm (5.3 m • kg, 38 ft • lb)</p> |
|---|---|

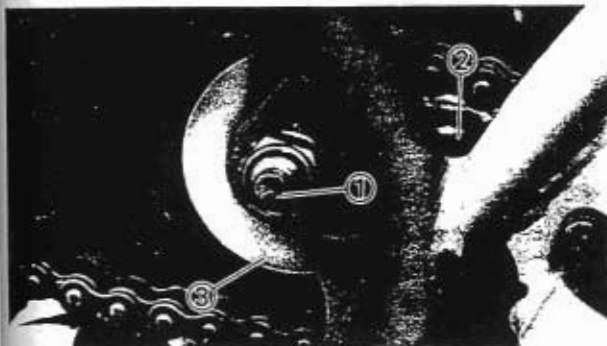

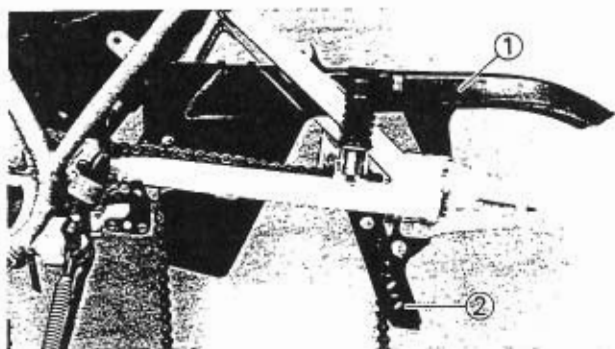
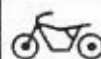

4. Tighten:
- Bolts (chain guide) ①
 - Bolts (chain cover) ②

| | |
|--|--|
| | Bolt (chain guide): 7 Nm (0.7 m•kg, 5.1 ft•lb) |
| | Bolt (chain cover): 7 Nm (0.7 m•kg, 5.1 ft•lb) |

5. Install:
- Rear shock absorber
Refer to the "Rear Shock Absorber" section.
6. Install:
- Rear wheel
Refer to "REAR WHEEL—INSTALLATION" section.

| | |
|--|---|
| | Nut (rear wheel axle): 85 Nm (8.5 m•kg, 61 ft•lb) |
|--|---|

7. Adjust:
- Drive chain slack ③
Refer to the "DRIVE CHAIN SLACK ADJUSTMENT" section in the CHAPTER 3.

| | |
|--|--|
| | Drive chain slack: 35~40 mm (1.40~1.60 in) |
|--|--|

Rear shock absorber

Reverse the "REMOVAL" procedure.

Note the following points.

1. Lubricate:
- Collars
 - Bushes
 - Pin
 - Bolt

| | |
|--|---|
| | Recommended lubricant: Lithium soap base grease |
|--|---|

2. Install:
- Swingarm
Refer to the "Swingarm" section

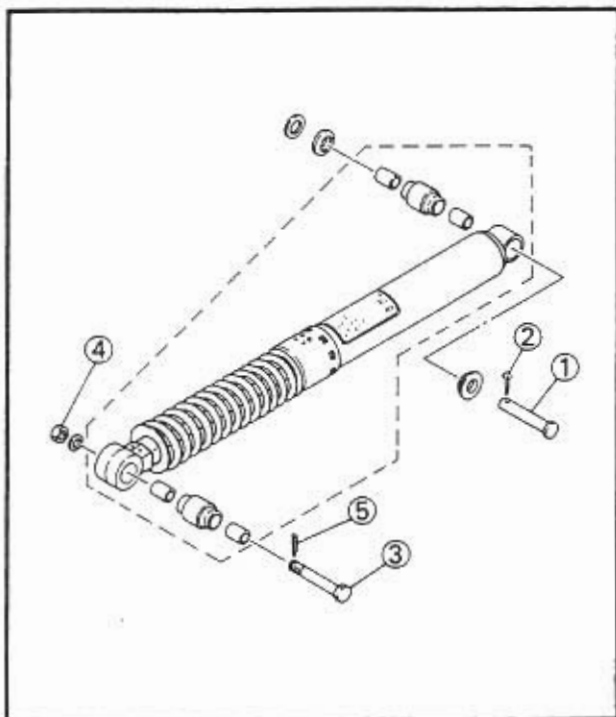

3. Install:
- Pin (shock absorber—lower) ①
 - Cotter pin ②

NOTE: _____

Bend the ends of the cotter pin.

WARNING _____

Always use a new cotter pin.

4. Install:
- Bolt (shock absorber—upper) ③
 - Nut ④
5. Tighten:
- Bolt (shock absorber—upper) ③

| | |
|---|---|
|  | Bolt (shock absorber—upper): 32 Nm (3.2 m • kg, 23 ft • lb) |
|---|---|

6. Install:
- Cotter pin ⑤

NOTE: _____

Bend the ends of the cotter pin.

WARNING _____

Always use a new cotter pin.

DRIVE CHAIN AND SPROCKETS

- ① Drive sprocket
- ② Chain joint
- ③ Drive chain

| | |
|---|--|
| A | DRIVE CHAIN: |
| B | TYPE: 428 DS/DAIDO |
| C | NO. OF LINKS: 117 + joint |
| D | DRIVE CHAIN SLACK: 35~40 mm (1.40~1.60 in) |

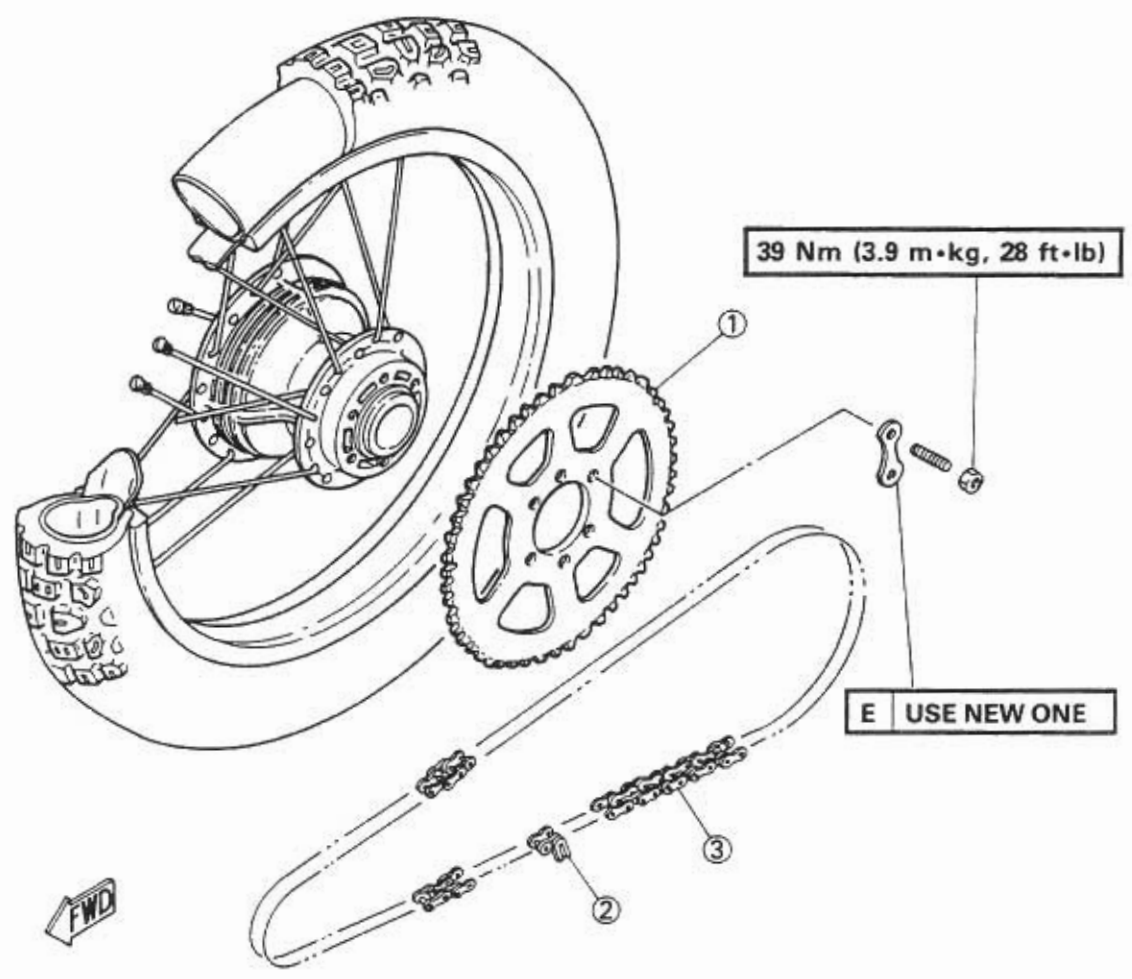

NOTE: _____

Before removing the drive chain and the sprocket, drive chain stretch should be checked.

REMOVAL

1. Place the motorcycle on a level place.

⚠ WARNING _____

Securely support the motorcycle so there is no danger of it falling over.

2. Remove:
 - Crankcase cover (left) ①

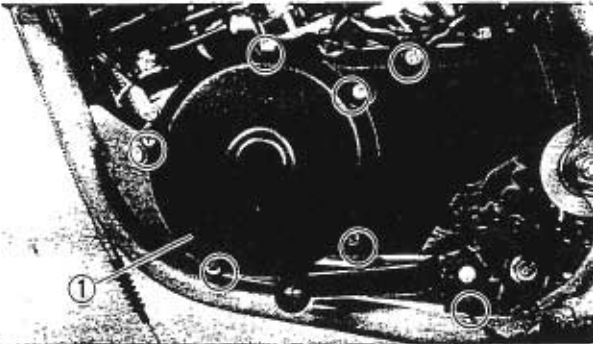

3. Straighten:
 - Lock washer tab ①
4. Loosen:
 - Nut (drive sprocket) ②

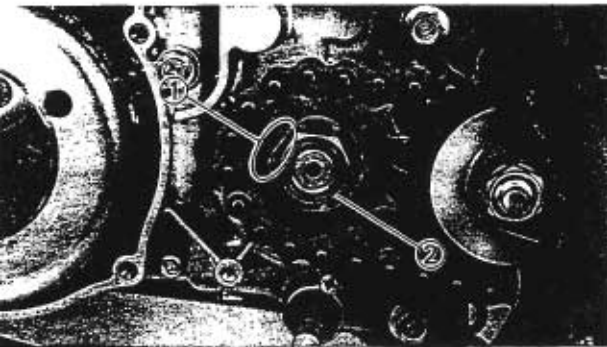

NOTE: _____

When loosening the drive sprocket nut, apply the rear brake pedal and transmission gear to the 6th position.

5. Remove:
 - Clip (master link) ①
 - Plate (master link) ②
 - Master link ③
 - Drive chain ④

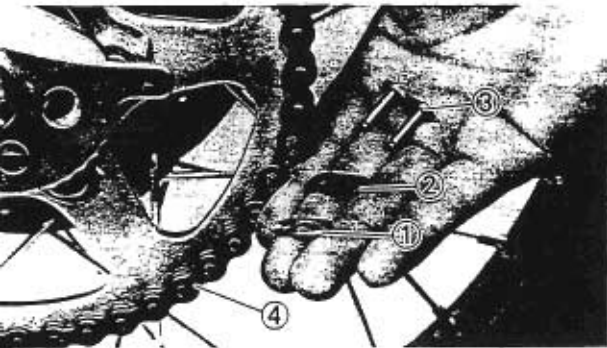

6. Remove:
 - Chain case ①
 - Chain guide ②

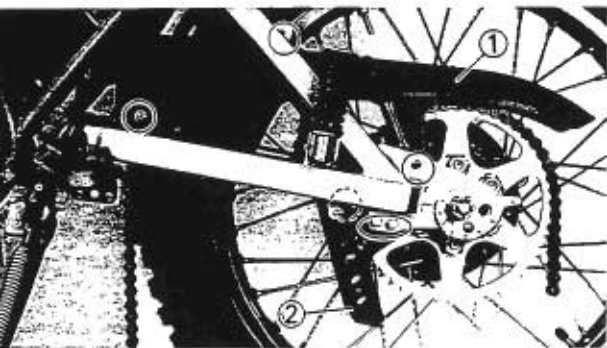

7. Remove:
 - Rear wheel

Refer to the "REAR WHEEL—REMOVAL" section.

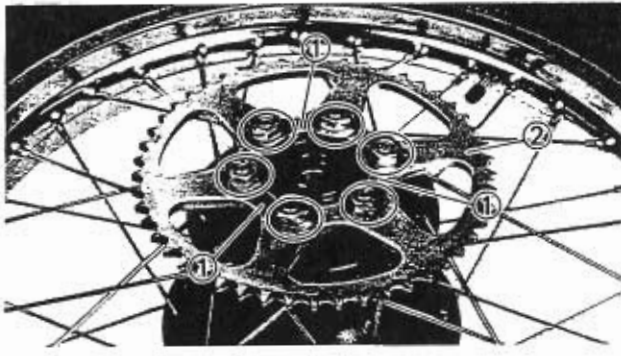

8. Remove:
- Lock washer ①
 - Driven sprocket ②

INSPECTION

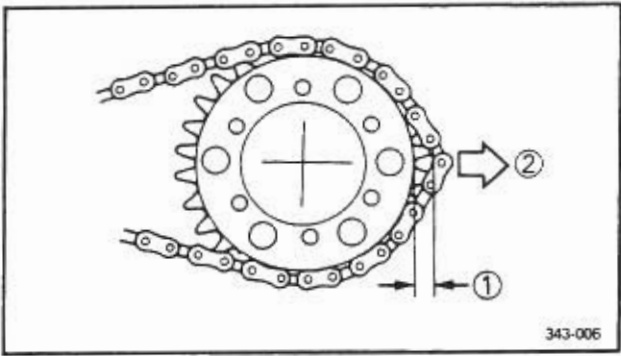

1. Check:
- Drive chain stretch
Pull ② the chain away from the driven sprocket.
Distance chain/sprocket higher than 1/2 tooth ① → Replace drive chain.

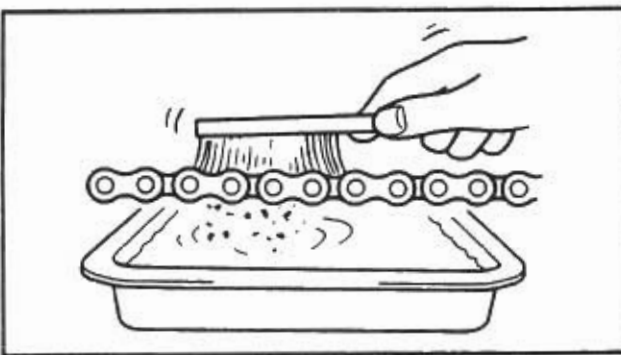

2. Clean:
- Drive chain
Place it in kerosene, and brush off as much dirt as possible. Then remove the chain from the kerosene and dry the chain.

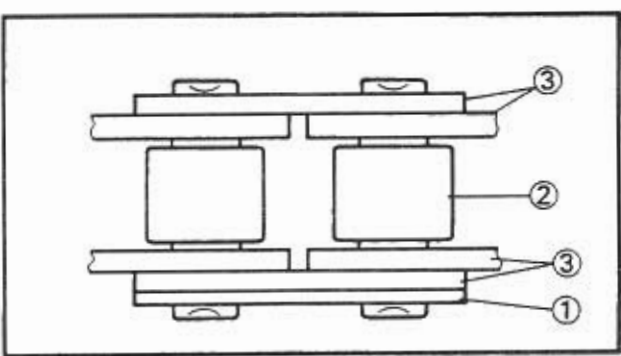

3. Inspect:
- Clip ① (drive chain)
Damage → Replace drive chain.
 - Rollers ②
 - Side plates ③
Damage/Wear → Replace drive chain.

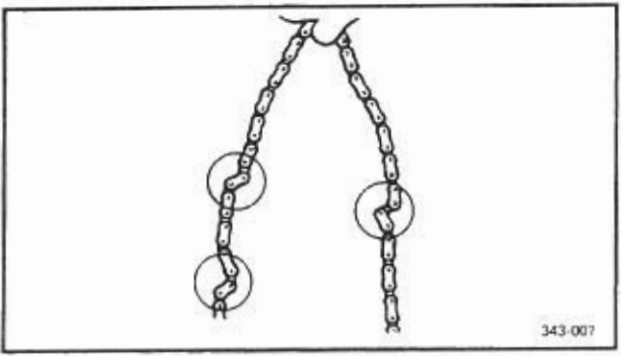

4. Lubricate:
- Drive chain

| | |
|---|--|
|  | Drive chain lubricant: SAE 10W30 motor oil |
|---|--|

5. Inspect:
- Drive chain stiffness
Stiff → Clean and lubricate or replace.

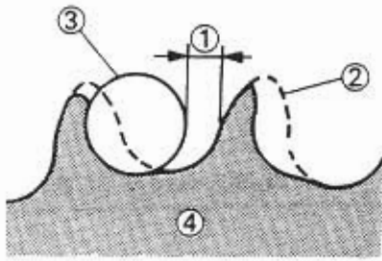

343-014

6. Inspect:

- Drive sprocket
 - Driven sprocket
- More than 1/4 teeth ① wear → Replace sprocket.
Bent teeth → Replace sprocket.

- ② Correct
- ③ Roller
- ④ Sprocket

Replacement steps:

- Straighten the lock washer tabs and remove the driven sprocket.
- Install a new driven sprocket and lock washers.

⚠ WARNING

Always use new lock washers.



Nut (driven sprocket):
39 Nm (3.9 m • kg, 28 ft • lb)

- Bend the washer tabs along the nut flats.

INSTALLATION

Reverse the "REMOVAL" procedure.
Note the following points.

1. Install:

- Lock washer ② (new)
- Driven sprocket ①



Nut (driven sprocket):
39 Nm (3.9 m • kg, 28 ft • lb)

2. Install:

- Swing arm
- Refer to the "SWING ARM—INSTALLATION" section.



Nut (pivot shaft):
53 Nm (5.3 m • kg, 38 ft • lb)

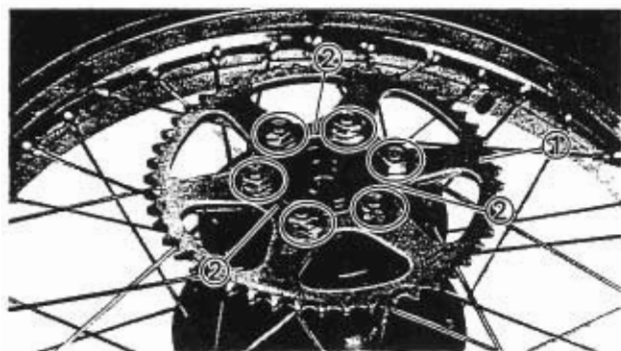

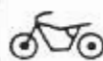

3. Install:

- Rear wheel

Refer to the "REAR WHEEL—INSTALLATION" section.



Nut (rear wheel axle):
85 Nm (8.5 m • kg, 61 ft • lb)

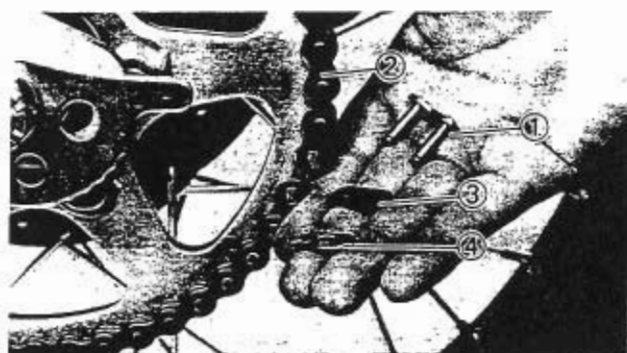

4. Install:

- Master link ①
- Drive chain ②
- Plate (master link) ③
- Clip (master link) ④

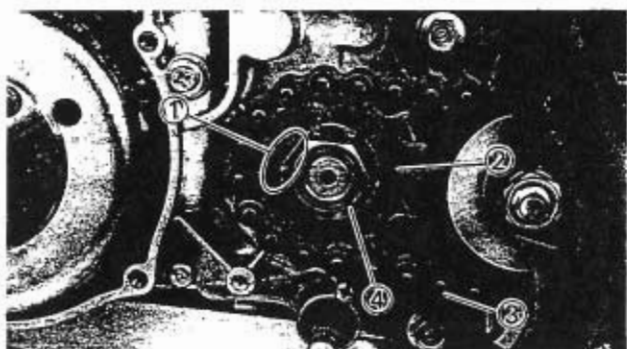

5. Install:

- Lock washer ①
- Drive sprocket ②
- Drive chain ③

6. Tighten:

- Nut (drive sprocket) ④



Nut (drive sprocket):
55 Nm (5.5 m • kg, 40 ft • lb)

NOTE:

Tighten the nut (drive sprocket) while applying the rear brake.

⚠ WARNING

Always use a new lock washer.

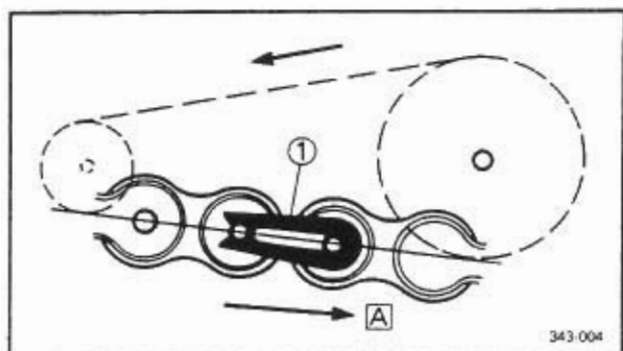

7. Bend the lock washer tab along the nut flats.

⚠ WARNING

Make sure that the clip ① is installed in the correct direction. Otherwise, the drive chain will be separated.

Ⓐ Turning direction



CHAPTER 7. ELECTRICAL

| | |
|---|------|
| DT175D CIRCUIT DIAGRAM | H-3 |
| COLOR CODE | H-3 |
| ELECTRICAL COMPONENTS | H-4 |
| CHECKING OF CONNECTIONS | H-5 |
| CHECKING OF SWITCHES | H-5 |
| SWITCH CONNECTION AS SHOWN IN MANUAL | H-5 |
| CHECKING SWITCH FOR TERMINAL CONNECTION | H-5 |
| CHECKING OF BULBS (FOR HEADLIGHT, TAIL/BRAKE, LIGHT, FLASHER LIGHT, METER LIGHT, ETC.) | H-7 |
| KINDS OF BULBS | H-7 |
| CHECKING BULB CONDITION | H-7 |
| IGNITION SYSTEM | H-8 |
| CIRCUIT DIAGRAM | H-8 |
| TROUBLESHOOTING | H-8 |
| CHARGING SYSTEM | H-12 |
| CIRCUIT DIAGRAM | H-12 |
| TROUBLESHOOTING | H-12 |
| LIGHTING SYSTEM | H-13 |
| CIRCUIT DIAGRAM | H-13 |
| TROUBLESHOOTING | H-14 |
| LIGHTING SYSTEM CHECK | H-15 |
| SIGNAL SYSTEM | I-1 |
| CIRCUIT DIAGRAM | I-1 |
| TROUBLESHOOTING | I-1 |
| SIGNAL SYSTEM CHECK | I-2 |

ELECTRICAL

DT175D CIRCUIT DIAGRAM

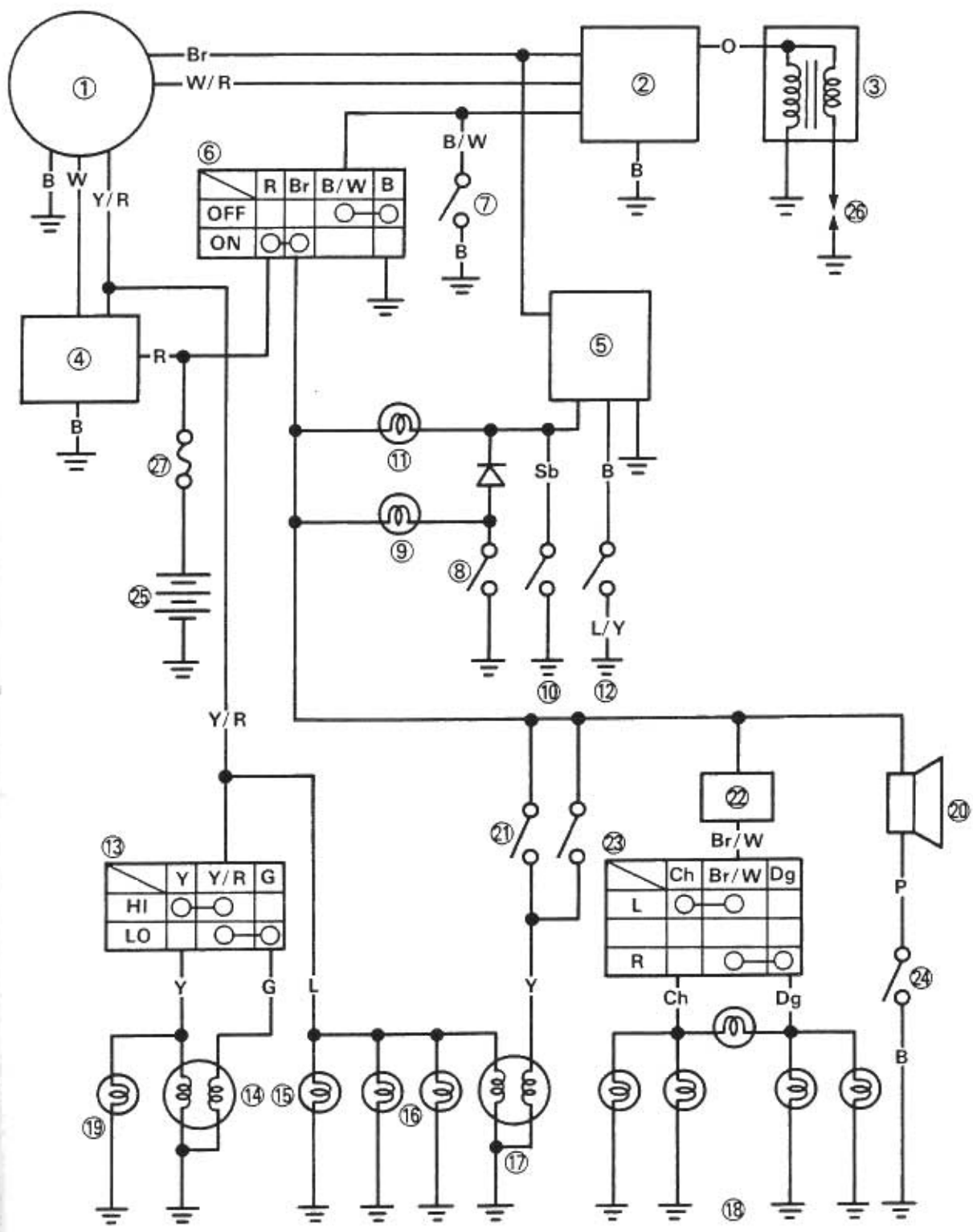



- ① CDI magneto
- ② CDI unit
- ③ Ignition coil
- ④ Rectifier/Regulator
- ⑤ Control unit
- ⑥ Main switch
- ⑦ "ENGINE STOP" switch
- ⑧ Oil level gauge
- ⑨ "OIL" warning light
- ⑩ Neutral switch
- ⑪ "NEUTRAL" indicator light
- ⑫ Sidestand switch
- ⑬ "LIGHTS" (Dimmer) switch
- ⑭ Headlight
- ⑮ Auxiliary light
- ⑯ Meter light
- ⑰ Tail/brake light
- ⑱ Flasher light
- ⑲ "HIGH BEAM" indicator light
- ⑳ Horn
- ㉑ Brake switch
- ㉒ Flasher relay
- ㉓ "TURN" switch
- ㉔ "HORN" switch
- ㉕ Battery
- ㉖ Spark plug
- ㉗ Fuse

COLOR CODE

| | | | | | |
|---|--------|----|------------|------|-------------|
| B | Black | G | Green | L/Y | Blue/Yellow |
| R | Red | W | White | B/W | Black/White |
| O | Orange | Ch | Chocolate | W/R | White/Red |
| L | Blue | Dg | Dark green | W/L | White/Blue |
| P | Pink | Sb | Sky blue | Y/R | Yellow/Red |
| Y | Yellow | Br | Brown | Br/W | Brown/White |

ELECTRICAL COMPONENTS (1)

- ① Rectifier/Regulator
- ② Control unit
- ③ Sidestand switch
- ④ Horn
- ⑤ Flasher relay
- ⑥ CDI unit

IGNITION COIL:
PRIMARY COIL RESISTANCE:
0.8 ~ 1.2Ω at 20°C (68°F)
SECONDARY COIL RESISTANCE:
4.72 ~ 7.08kΩ at 20°C (68°F)

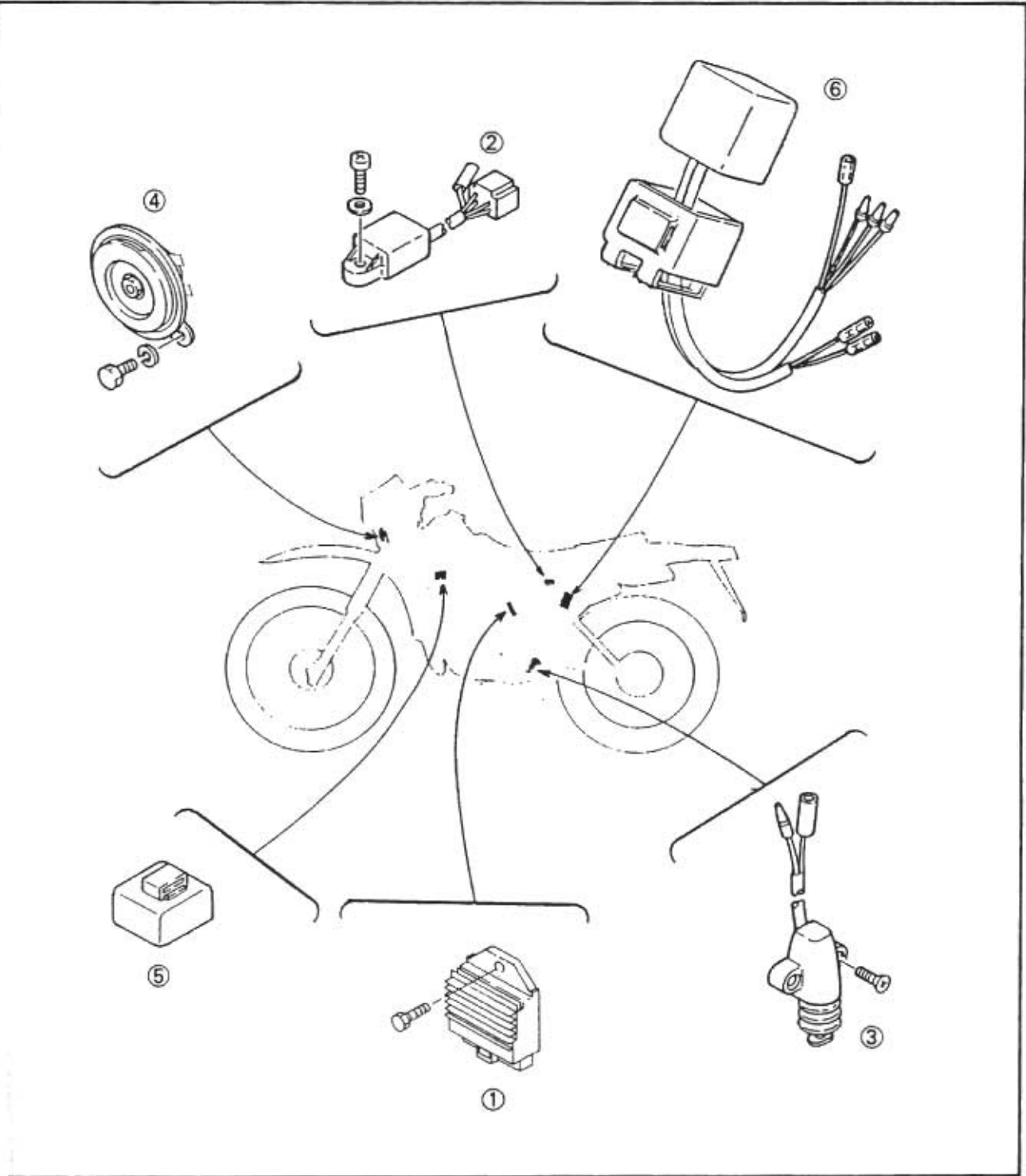



ELECTRICAL COMPONENTS (2)

- ① Wireharness
- ② Fuse
- ③ Battery
- ④ Brake switch
- ⑤ Neutral switch
- ⑥ Ignition coil
- ⑦ Oil level gauge
- ⑧ Main switch

BATTERY:
CAPACITY:
12V 3AH
SPECIFIC GRAVITY:
1.280 at 20°C (68°F)

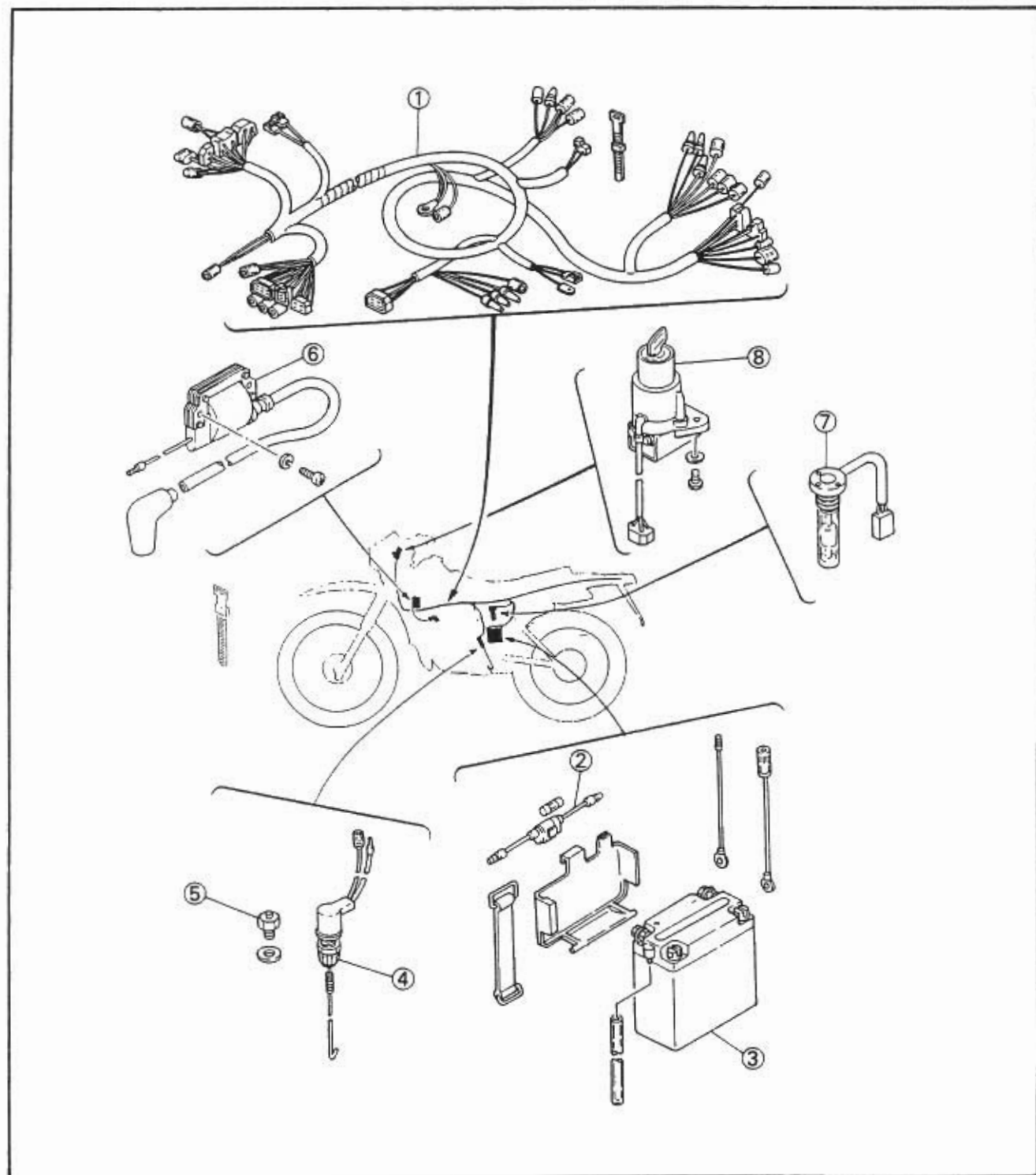

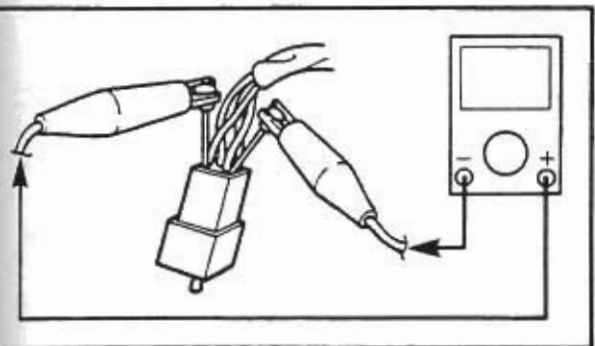
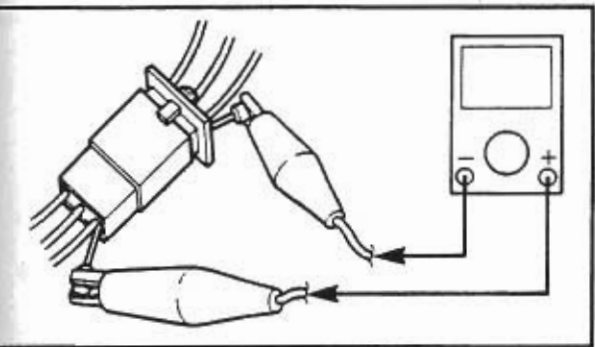
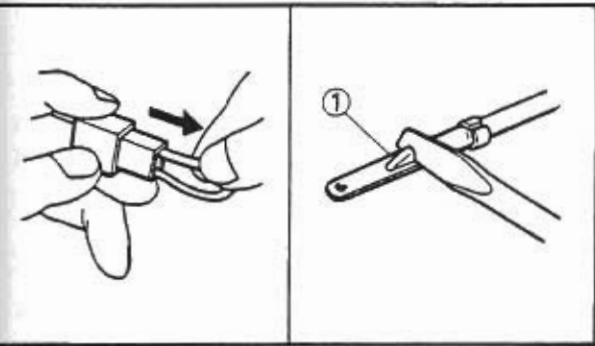
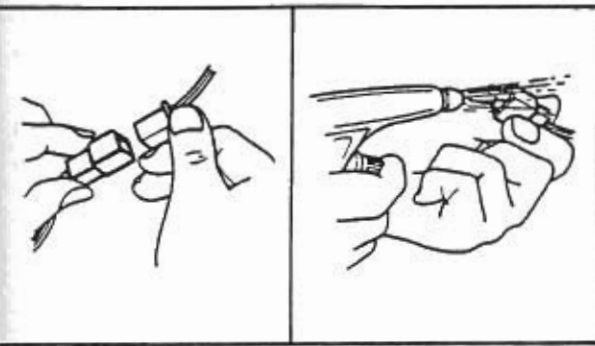

CHECKING OF CONNECTIONS

Dealing with stains, rust, moisture, etc. on the connector.

1. Disconnect:
 - Connector
2. Dry each terminal by an air blower.
3. Connect and disconnect the connector two or three times.
4. Pull the lead to check that it will not come off.
5. If the terminal comes off, bend up the pin ① and reinsert the terminal into connector.

6. Connect:
 - Connector
7. Check for continuity by a tester.

NOTE:

- If there is no continuity, clean the terminals.
- Be sure to perform the above steps 1 to 7 when checking the wireharness.
- When replacing the CDI unit, be sure to check its connector.
- For a field remedy, use a contact revitalizer available on the market.
- Use the tester on the connector as shown.



CHECKING OF SWITCHES

SWITCH CONNECTION AS SHOWN IN MANUAL

The manual contains a connection chart as shown left showing the terminal connections of the switches (e.g., main switch, handlebar switch, bracket switch, lighting switch etc.).

The extreme left column indicates the switch positions and the top line indicates the colors of leads connected with the terminals in the switch component.

"○—○" indicates the terminals between which there is a continuity of electricity; i.e., a closed circuit at the respective switch positions.

In this chart:

"R and Br" and "L/W and L/R" are continuous with the "ON" switch position.

"B and B/W" is continuous with the "OFF" switch position.

"B and B/W" is continuous with the "LOCK" switch position.

"B and B/W" and "R and L/R" are continuous with the "P" switch position.

| | B | B/W | R | Br |
|------|-----|-----|-----|----|
| ON | | | ○—○ | |
| OFF | ○—○ | | | |
| LOCK | ○—○ | | | |

CHECKING SWITCH FOR TERMINAL CONNECTION

Before checking the switch, refer to the connection chart as shown above and check for the correct terminal connection (closed circuit) by the color combination.

To explain how to check the switch, the main switch taken for example in the following.

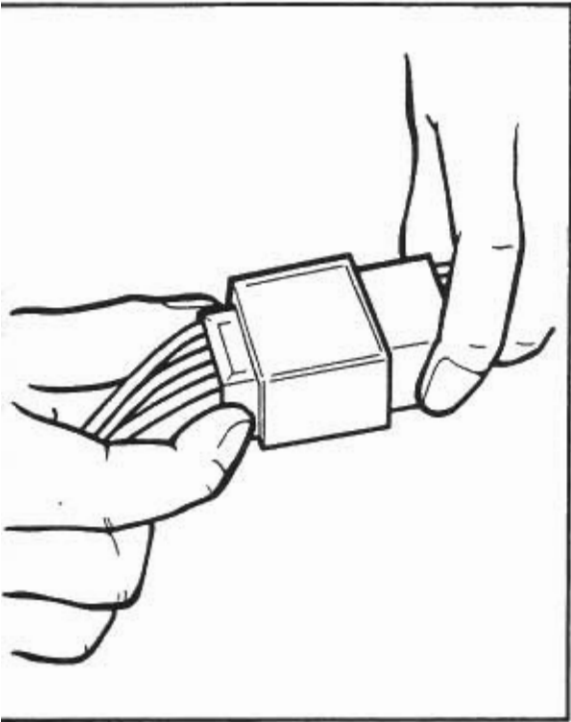

1. Disconnect the main switch coupler from the wireharness.

CAUTION: _____

Never disconnect the main switch coupler by pulling the leads. Otherwise, leads may be pulled off the terminals inside the coupler.

2. Inspect whether any lead is off the terminal inside the coupler. If it is, repair it.

NOTE: _____

If the coupler is clogged with mud or dust, blow it off by compressed air.

| | B | B/W | R | Br |
|------|-----|-----|-----|----|
| ON | | | ○—○ | |
| OFF | ○—○ | | | |
| LOCK | ○—○ | | | |

3. Use the connection chart to check the color combination for continuity (a closed circuit). In this example, the continuity is as follows.

"R and Br" and "L/W and L/R" are continuous with the "ON" switch position.

"B and B/W" is continuous with the "OFF" switch position.

"B and B/W" is continuous with the "LOCK" switch position.

"B and B/W" and "R and L/R" are continuous with the "P" switch position.

Please note that there is no continuity (an open circuit) at all for the color combinations other than the above.

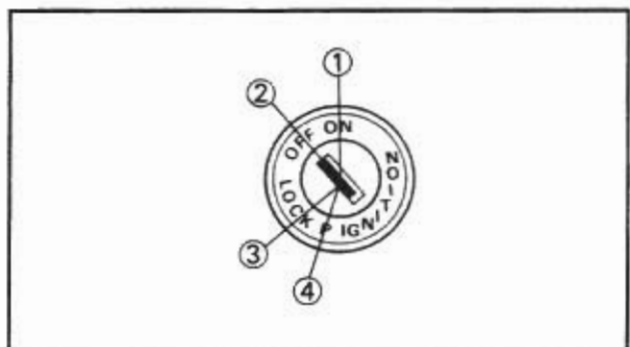
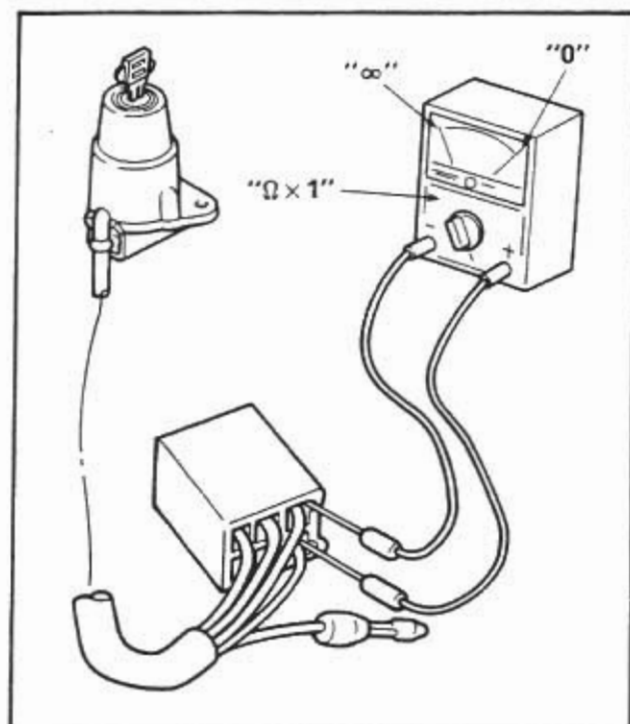

4. Check the switch component for the continuity between "R and Br".

Checking steps:

- Turn the switch key to the "ON", "OFF", "LOCK" and "P" several times.
- Set the pocket tester selector to the " $\Omega \times 1$ ".
- Connect the tester (+) lead to the "R" lead terminal in the coupler and the (-) lead to the "Br" lead terminal.

NOTE:

Use thin probes for checking the continuity. Otherwise, the probes may contact other-terminals inside the coupler.

- Check the continuity between "R" and "Br" at the respective switch position of "ON" ①, "OFF" ②, "LOCK" ③, and "P" ④.

There must be continuity (the tester indicating "0") at the "ON" switch position, and there must be no continuity (the tester indicating " ∞ ") at "OFF", "LOCK" or "P".

There is something wrong between "R" and "Br" if there is no continuity at the "ON" position or if there is some continuity either at the "OFF" or "LOCK" or "P".

NOTE:

Check the switch for continuity several times.

5. Next go on to checking of the continuity between "B" and "B/W", "L/W and L/R", and "R and L/R" at the respective switch positions, as in the same manner mentioned above.

6. If there is something wrong with any one of the combinations, replace the switch component.



CHECKING OF BULBS (FOR HEADLIGHT, TAIL/BRAKE LIGHT, FLASHER LIGHT, METER LIGHT, ETC.)

Check the bulb terminal continuity for the condition of the bulb.

KINDS OF BULBS

The bulbs used in the motorcycle are classified as shown left by the shape of the bulb socket.

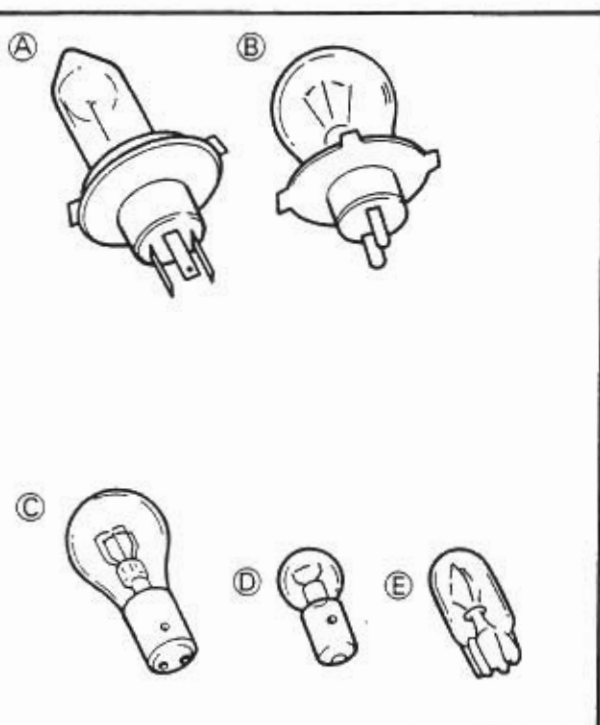

(A) and (B) are mainly used for the headlight.

(C) is mainly used for the flasher light and tail/brake light.

(D) and (E) are mainly used for the meter light and other indicator lights.

CHECKING BULB CONDITION

1. Remove the bulb.

NOTE:

- Bulbs of the (A) and (B) type uses a bulb holder. Remove the bulb holder before removing the bulb itself. Most of the bulb holder for this type can be removed by turning them counterclockwise.
- Most of the bulbs of (C) and (D) type can be removed from the bulb sockets by pushing and turning them counterclockwise.
- Bulbs of the (E) type can be removed from the bulb sockets by simply pulling them out.

CAUTION:

Be sure to hold the socket firmly when removing the bulb. Never pull the lead. Otherwise, the lead may be pulled off the terminal in the coupler.

WARNING

Keep flammable products or your hands away from the headlight bulb while it is on. It will be hot. Do not touch the bulb until it cools down.



2. Check the bulb terminals for continuity.

Checking steps:

- Set the pocket tester selector to the " $\Omega \times 1$ ".
- Connect the tester lead to the respective bulb terminals. Take for example a 3-terminal bulb as shown left. First check the continuity between the ① and ② terminal by connecting the tester (+) lead to the ① terminal and the tester (-) lead to the ② terminal. Then check the continuity between the ① and ③ terminals by connecting the tester (+) lead still to the ① terminal and the tester (-) lead to the ③ terminal. If the tester shown " ∞ " in either case, replace the bulb.

3. Check the bulb socket by installing a proven bulb to it. As in the checking of bulbs, connect the pocket tester leads to the respective leads of the socket and check for continuity in the same manner as mentioned above.

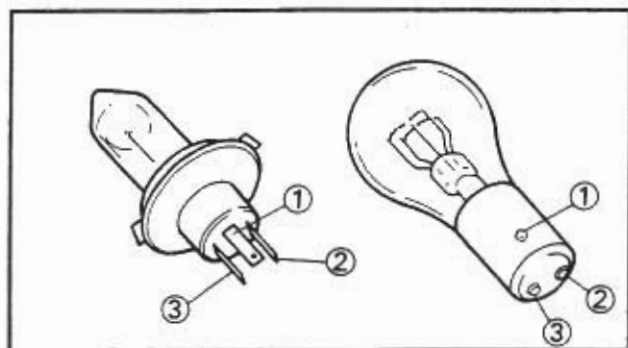



TROUBLESHOOTING

IF IGNITION SYSTEM SHOULD BECOME INOPERATIVE
(NO SPARK OR INTERMITTENT SPARK)

Procedure

Check;

- | | |
|------------------------------|--|
| 1. Spark plug | 7. Neutral switch |
| 2. Ignition spark gap | 8. Sidestand switch |
| 3. Spark plug cap resistance | 9. Pickup coil resistance |
| 4. Ignition coil resistance | 10. Source coil resistance |
| 5. Main switch | 11. Wiring connection (entire ignition system) |
| 6. "ENGINE STOP" switch | 12. CDI unit |

NOTE:

- Remove the following parts before troubleshooting.
 - 1) Front cover
 - 2) Side cover (left)
 - 3) Seat
 - 4) Fuel tank



Ignition checker:
P/N. 90890-06754

Pocket tester:
P/N. 90890-03112

| | |
|--|---|
| 1. Spark plug | |
| <ul style="list-style-type: none"> •Check the spark plug condition. •Check the spark plug type. •Check the spark plug gap. Refer to the "SPARK PLUG INSPECTION" section in the CHAPTER 3. | |
| Standard spark plug: BR8ES (N.G.K.) | |
| | Spark plug gap: 0.7~0.8 mm (0.028~0.032 in) |

INCORRECT

Repair or replace spark plug.

CORRECT

*



2. Ignition spark gap

- Disconnect the spark plug gap from spark plug.
 - Connect the ignition checker ① as shown.
- ② Spark plug

- Start the engine, and increase the spark gap until misfire occurs.



Minimum spark gap:
6 mm (0.24 in)



Ignition checker:
90890-06754

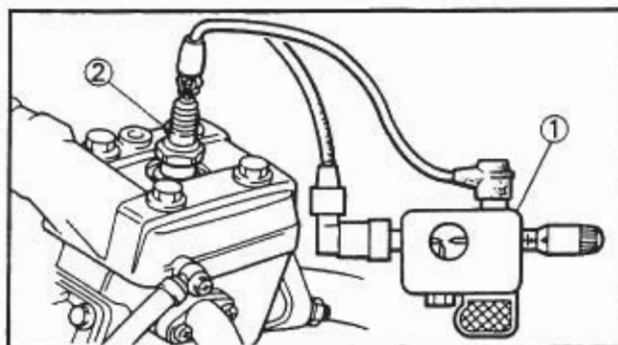

MEETS SPECIFICATION

Ignition system is good.

OUT OF SPECIFICATION
OR NO SPARK

3. Spark plug cap resistance

- Remove the spark plug cap.
- Connect the pocket tester ($\Omega \times 1k$) to the spark plug cap.

- Check the spark plug cap for specified resistance.



Spark plug cap resistance:
5.46 ~ 7.34k Ω at 20°C (68°F)

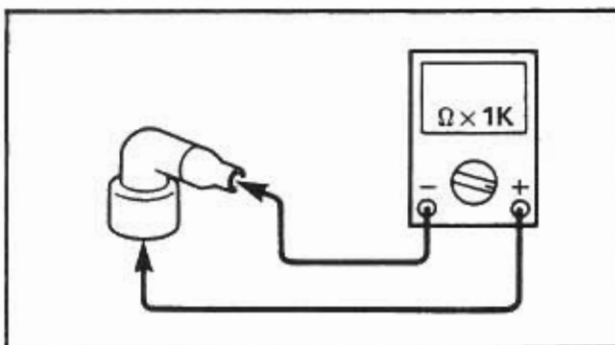

OUT OF SPECIFICATION

Spark plug cap is faulty, replace it.

MEETS SPECIFICATION

*



4. Ignition coil resistance

- Disconnect the ignition coil lead (Orange) from the wireharness.
- Connect the pocket tester ($\Omega \times 1$) to the ignition coil.

Tester (+) lead \rightarrow Orange ① lead
 Tester (-) lead \rightarrow Ignition coil base

- Check the primary coil for specified resistance.



Primary coil resistance:
 0.8 ~ 1.2 Ω at 20°C (68°F)
 (Orange — coil base)

- Connect the pocket tester ($\Omega \times 1k$) to the ignition coil.

Tester (+) lead \rightarrow Spark plug lead ①
 Tester (-) lead \rightarrow Ignition coil base

- Check the secondary coil for specified resistance.



Secondary coil resistance:
 4.72 ~ 7.08k Ω at 20°C (68°F)
 (Spark plug lead — coil base)

↓ BOTH MEET SPECIFICATIONS
 *

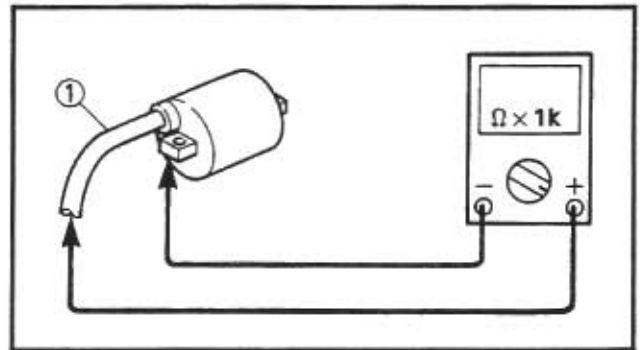
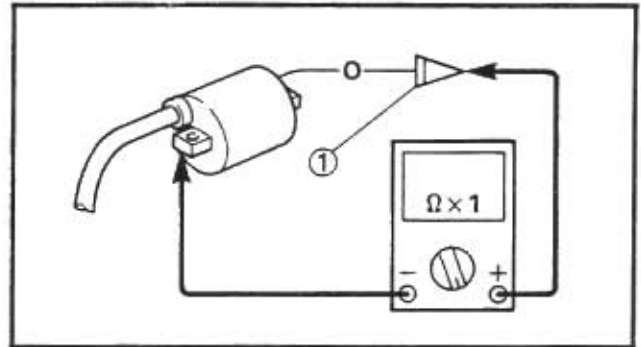

OUT OF SPECIFICATION

Ignition coil is faulty, replace it.



5. Main switch

- Disconnect the main switch coupler from the wireharness.
- Connect the pocket tester ($\Omega \times 1$) to the main switch.

Tester (+) lead → Black/White ① lead
 Tester (-) lead → Black ② lead

- Turn the main switch to "ON" and "OFF".
- Check the main switch for continuity.

| Switch position | Good condition | Bad condition | | |
|-----------------|----------------|---------------|---|---|
| OFF | ○ | × | ○ | × |
| ON | × | ○ | ○ | × |

○: Continuity ×: Nocontinuity

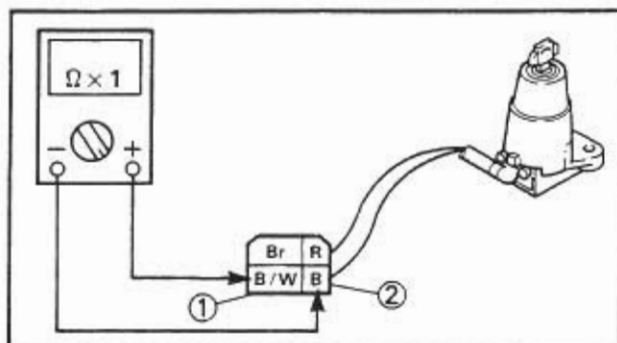

BAD CONDITION

Main switch is faulty, replace it.

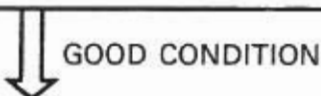

6. "ENGINE STOP" switch

- Disconnect the "ENGINE STOP" switch leads ① from the wireharness.
- Connect the pocket tester ($\Omega \times 1$) to the "ENGINE STOP" switch.

Tester (+) lead → Black/White ② lead
 Tester (-) lead → Black ③ lead

- Turn the "ENGINE STOP" switch to "OFF" and "RUN".
- Check the "ENGINE STOP" switch for continuity.

| Switch position | Good condition | Bad condition | | |
|-----------------|----------------|---------------|---|---|
| RUN | × | ○ | × | ○ |
| OFF | ○ | × | × | ○ |

○: Continuity ×: Nocontinuity

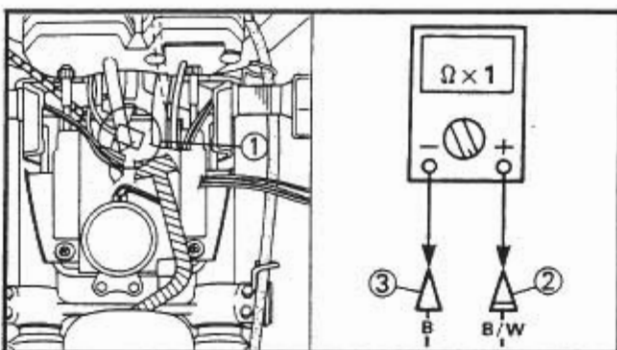

BAD CONDITION

Replace handlebar switch.

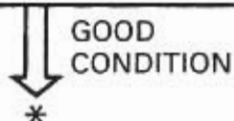



7. Neutral switch

- Disconnect the CDI magneto coupler ① from the wireharness.
- Connect the pocket tester ($\Omega \times 1$) to the neutral switch lead.

Tester (+) lead → Sky blue ② lead
Tester (-) lead → Frame ground

- Shift the transmission in neutral and gear.
- Check the neutral switch for continuity.

| Transmission position | Good condition | Bad condition | | |
|-----------------------|----------------|---------------|---|---|
| Neutral | ○ | × | × | ○ |
| Gear | × | ○ | × | ○ |

○: Continuity ×: Nocontinuity

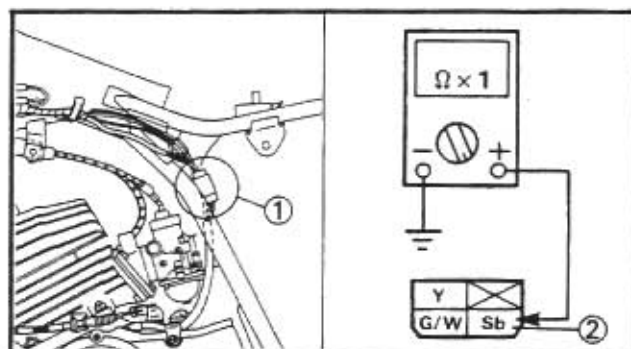

BAD CONDITION

Replace neutral switch.

GOOD CONDITION

8. Sidestand switch

- Disconnect the sidestand switch leads from the wireharness.
- Connect the pocket tester ($\Omega \times 1$) to the sidestand switch.

Tester (+) lead → Blue/Yellow ① lead
Tester (-) lead → Black ② lead

- Check the sidestand switch for continuity.

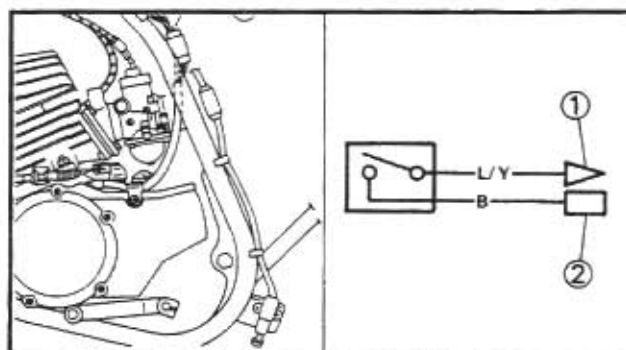

NO CONTINUITY

Replace the sidestand switch.

CONTINUITY





9. Pickup coil resistance

- Disconnect the CDI magneto leads (White/Red and Black) ① from the wireharness.
- Connect the pocket tester ($\Omega \times 1$) to the pickup coil.

Tester (+) lead → White/Red ② terminal
 Tester (-) lead → Black ③ terminal

- Check the pickup coil for specified resistance.

 Pickup coil resistance:
 8 ~ 12 Ω at 20°C (68°F)

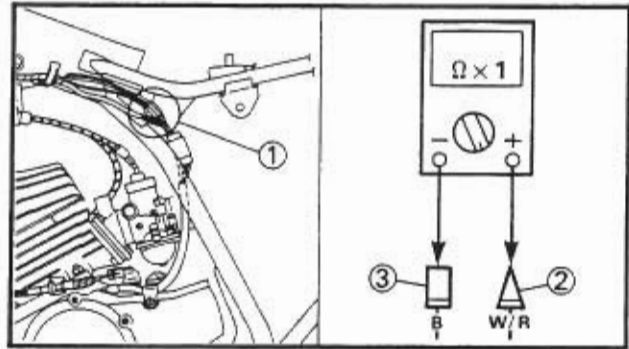

OUT OF SPECIFICATION

Replace pickup coil.

MEET SPECIFICATION

10. Source coil resistance

- Disconnect the CDI magneto coupler ① from the wireharness.
- Connect the pocket tester ($\Omega \times 100$) to the source coil.

Tester (+) lead → Black ② terminal
 Tester (-) lead → Brown ③ terminal

- Measure the source coil resistance.

 Source coil resistance:
 270 ~ 330 Ω at 20°C (68°F)

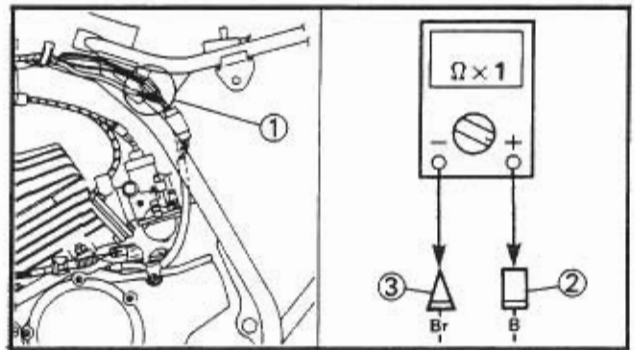

OUT OF SPECIFICATION

Replace source coil.

MEETS SPECIFICATION

11. Wiring connection

- Check the entire ignition system for connections. Refer to the "WIRING DIAGRAM" section.

POOR CONNECTION

Correct.

CORRECT



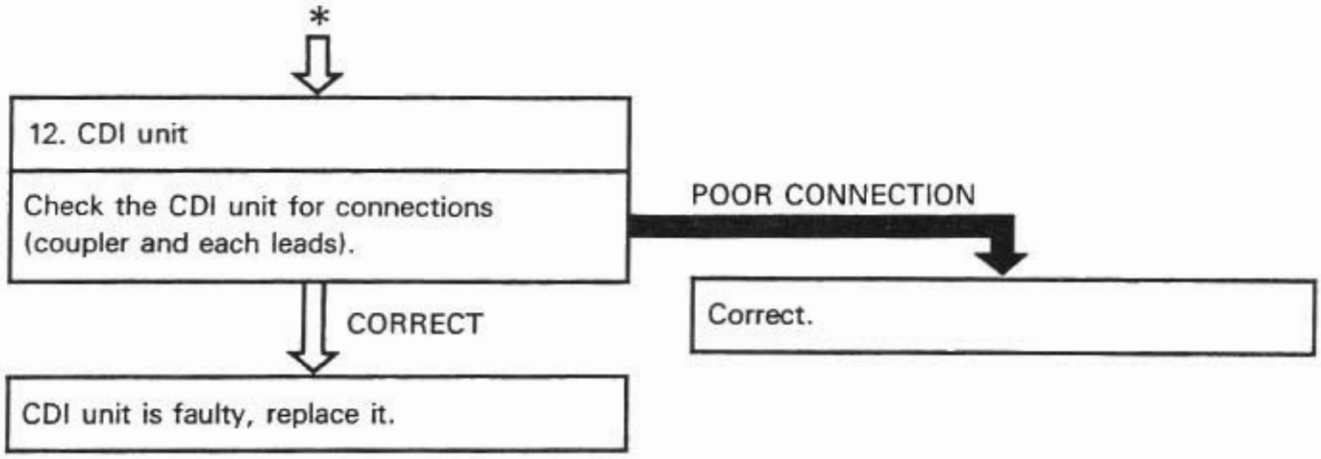



CHARGING SYSTEM
CIRCUIT DIAGRAM

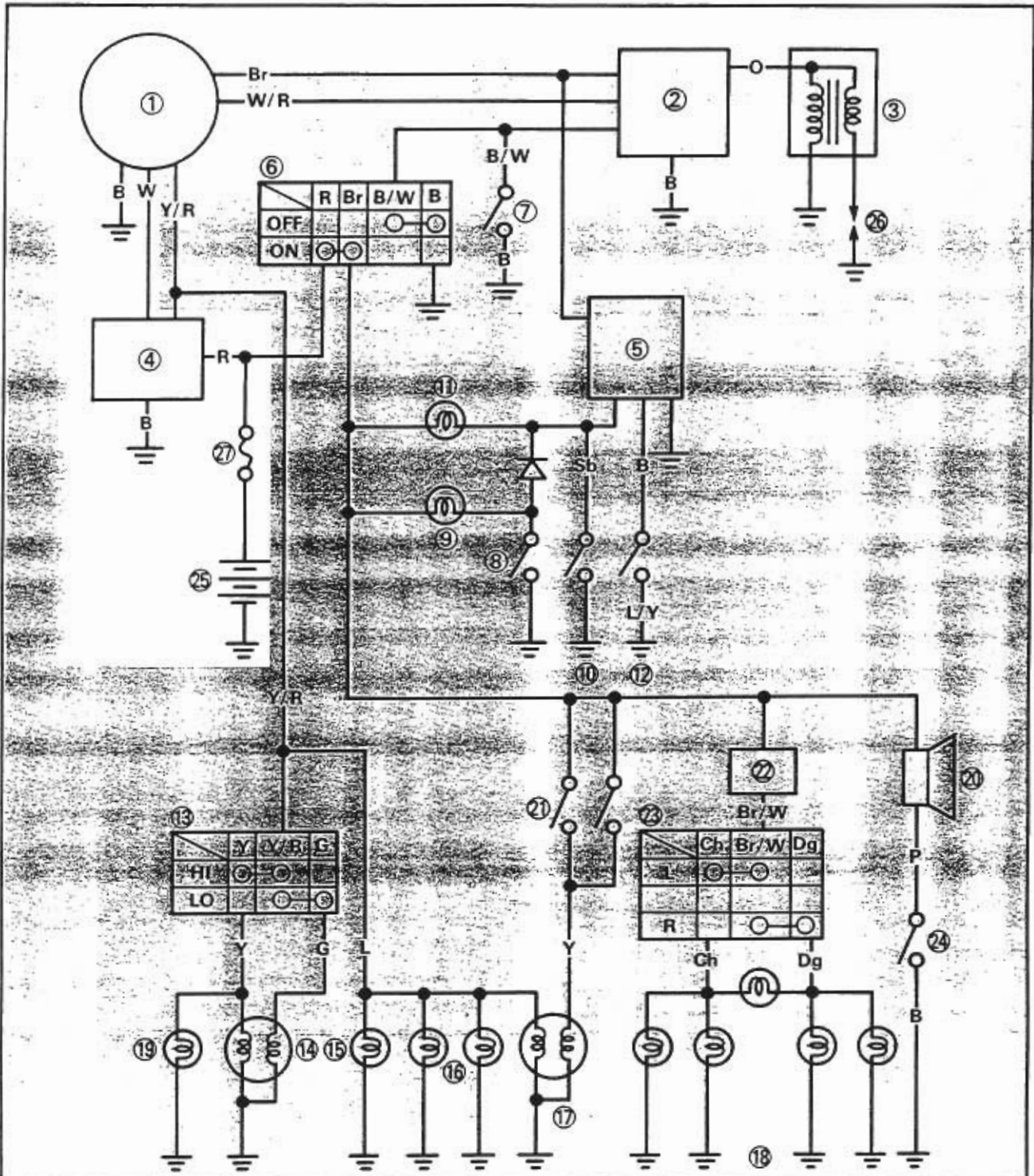

- ① CDI magneto
- ④ Rectifier/Regulator
- ②⑤ Battery
- ②⑦ Fuse



TROUBLESHOOTING

THE BATTERY IS NOT CHARGED.

Procedure

Check;

- | | |
|--|---|
| <ol style="list-style-type: none"> 1. Fuse 2. Battery 3. Charging voltage | <ol style="list-style-type: none"> 4. Charging coil resistance 5. Wiring connection (charging system) |
|--|---|

NOTE:

- Remove the following parts before troubleshooting.
 - 1) Side cover
 - 2) Fuel tank
 - 3) Seat
- Use the following special tool(s) in this troubleshooting.

| | |
|--|--|
| | <p>Inductive tachometer: P/N. 90890-03113</p> <p>Pocket tester: P/N. 90890-03112</p> |
|--|--|

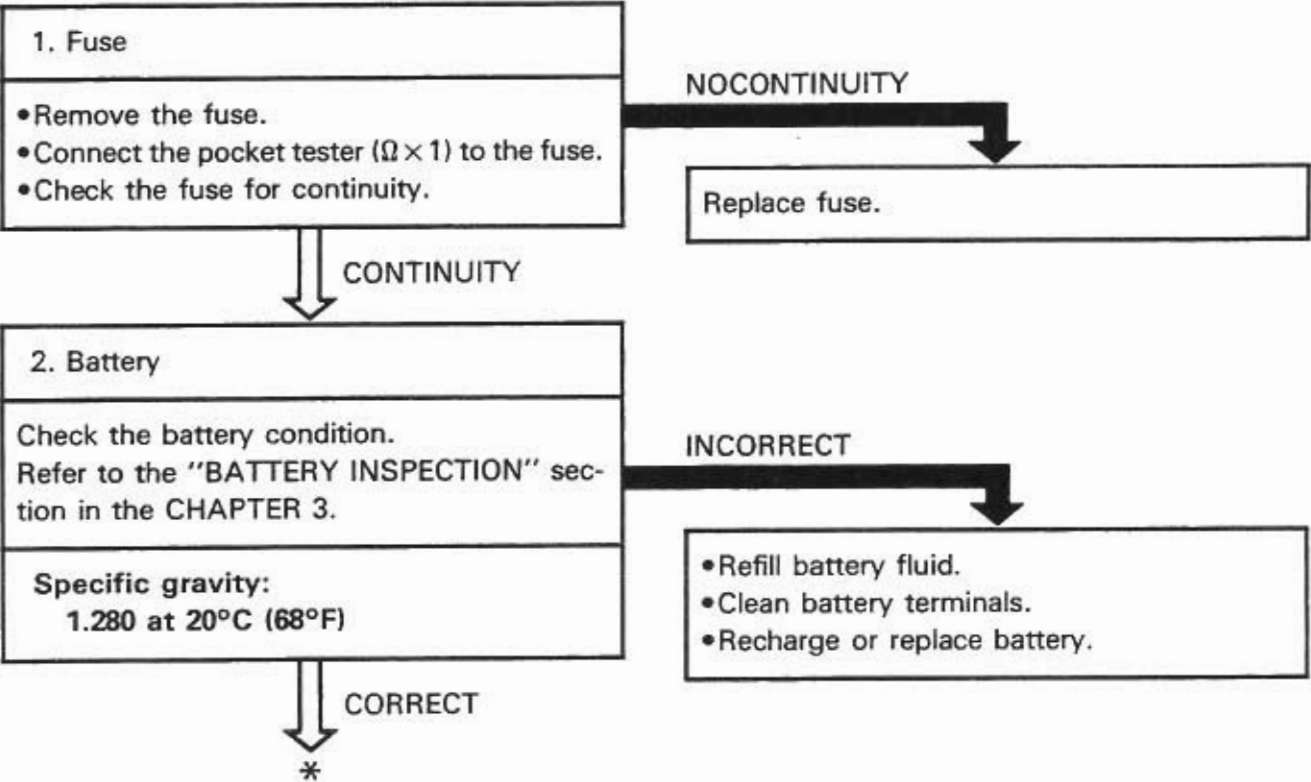



3. Charging voltage

- Connect the engine tachometer to spark plug lead.
- Connect the pocket tester (DC20V) to the battery.

Tester (+) lead → Battery (+) terminal
 Tester (-) lead → Battery (-) terminal

- Start the engine and accelerate to about 3,000 r/min.
- Measure the charging voltage.



Charging voltage:
 13.3 ~ 15.3V at 3,000 r/min

OUT OF SPECIFICATION

4. Charging coil resistance

- Disconnect the CDI magneto coupler and lead (Black) ① from the wireharness.
- Connect the pocket tester ($\Omega \times 1$) to the charging coil.

Tester (+) lead → Green/White ② lead
 Tester (-) lead → Black ③ lead

- Measure the charging coil resistance.



Charging coil resistance:
 0.24 ~ 0.36 Ω at 20°C (68°F)

MEETS SPECIFICATION

5. Wiring connection

- Check the entire ignition system for connections. Refer to the "WIRING DIAGRAM" section.

CORRECT

Replace rectifier/regulator.

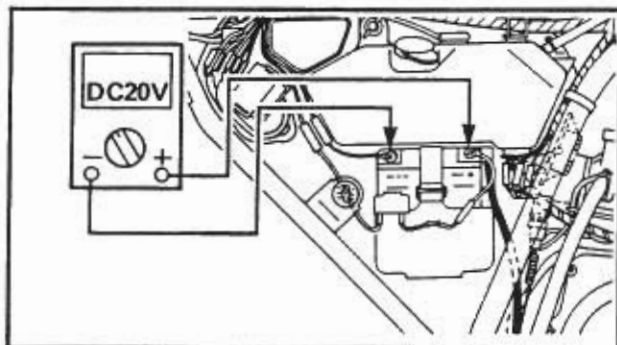

MEETS SPECIFICATION

Replace battery.

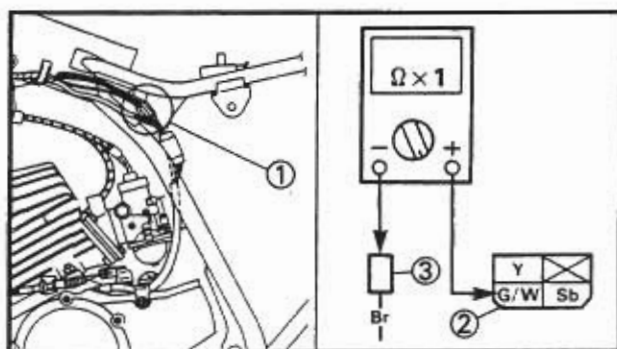

OUT OF SPECIFICATION

Replace stator assembly.

POOR CONNECTION

Correct.

LIGHTING SYSTEM
CIRCUIT DIAGRAM

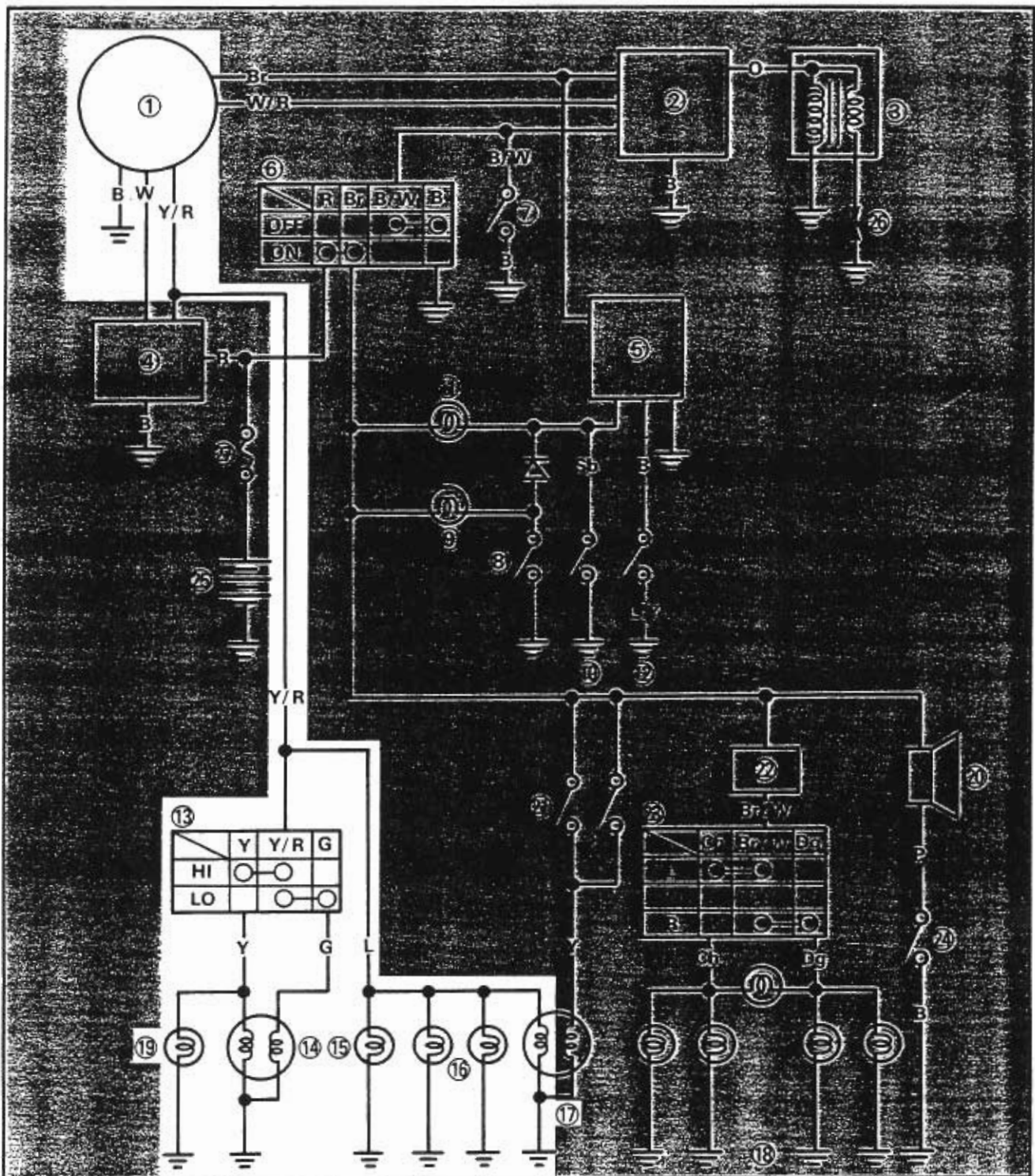

- ① CDI magneto
- ⑬ "LIGHTS" (Dimmer) switch
- ⑭ Headlight
- ⑮ Auxiliary light
- ⑯ Meter light
- ⑰ Tail/Brake light
- ⑲ "HIGH BEAM" indicator light



TROUBLESHOOTING

HEADLIGHT "HIGH BEAM" INDICATOR LIGHT, TAILLIGHT, AND/OR METER LIGHT DO NOT COME ON.

Procedure

Check;

1. "LIGHTS" (Dimmer) switch
2. Lighting coil resistance
3. Wiring connection

NOTE:

- Remove the following parts before troubleshooting.
 - 1) Side covers
 - 2) Seat
 - 3) Fuel tank
- Use the following special tool(s) in this troubleshooting.



Pocket tester:
P/N. 90890-03112

1. "LIGHTS" (Dimmer) switch

- Disconnect the handlebar switch (left) and headlight coupler ① from the wireharness.
- Check the switch component for the continuity between "Green ② and Yellow/Red ③" and "Yellow/Red ③ and Yellow ④". Refer to the "CHECKING OF SWITCHES" section.

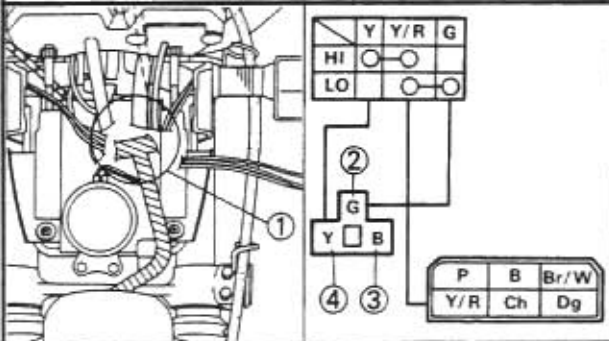

INCORRECT

Replace handlebar switch (left).

CORRECT

*



2. Lighting coil resistance

- Disconnect the CDI magneto coupler and lead (Black) ① from the wireharness.
- Connect the pocket tester ($\Omega \times 1$) to the lighting coil coupler.

Tester (+) lead → Yellow ② terminal
 Tester (-) lead → Black ③ terminal

- Measure the lighting coil resistance.

 **Lighting coil resistance:**
 0.14 ~ 0.22 Ω at 20°C (68°F)

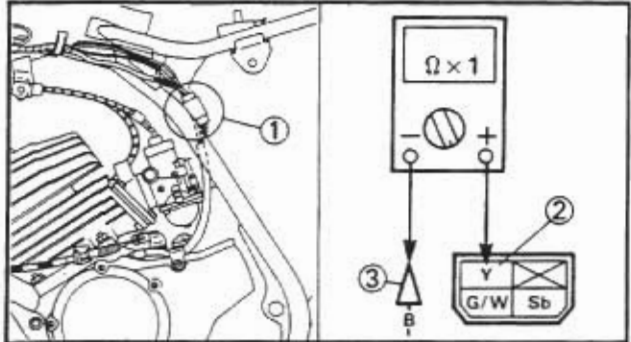

OUT OF SPECIFICATION

Replace stator assembly.

MEETS SPECIFICATION

3. Wiring connection

- Check the entire lighting system for connections. Refer to the "WIRING DIAGRAM" section.

POOR CONNECTION

Correct.

CORRECT

Check condition of each circuit for lighting system. Refer to "LIGHTING SYSTEM CHECK" section.



LIGHTING SYSTEM CHECK

1. Headlight and "HIGH BEAM" indicator light does not come on.

1. Bulb and bulb socket

- Check the bulb and bulb socket for continuity. Refer to the "CHECKING OF BULBS" section.

CONTINUITY

2. Voltage

- Connect the pocket tester (DC20V) to the headlight and "HIGH BEAM" indicator light couplers.

A When "LIGHTS" (Dimmer) switch is "LO" position.
B When "LIGHTS" (Dimmer) switch is "HI" position.

Headlight:
 Tester (+) lead → Yellow ① or Green ② lead
 Tester (-) lead → Black ③ lead
"HIGH BEAM" indicator light:
 Tester (+) lead → Yellow ④ lead
 Tester (-) lead → Black ⑤ lead

- Start the engine.
- Turn the "LIGHTS" (Dimmer) switch to "LO" or "HI" position.
- Check for voltage (12V) on the "Green" and "Yellow" lead at bulb socket connectors.

MEETS SPECIFICATION

This circuit is good.

NO CONTINUITY

Replace bulb and/or bulb socket.

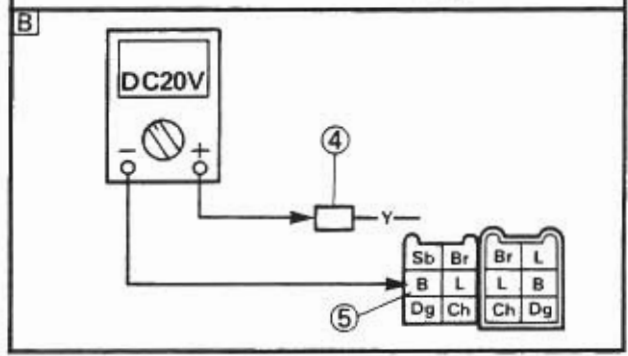
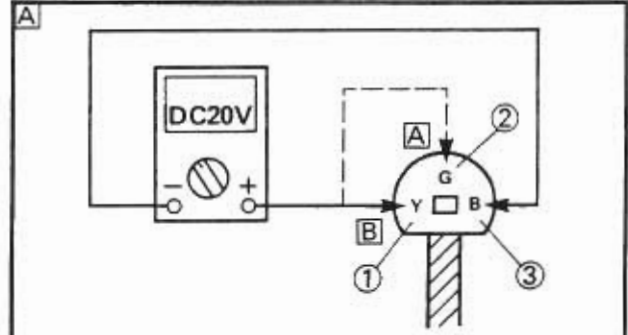

OUT OF SPECIFICATION

Wiring circuit from main switch to bulb socket connector is faulty, repair.



2. Meter light does not come on.

1. Bulb and bulb socket

- Check the bulb and bulb socket for continuity. Refer to the "CHECKING OF BULBS" section.

NO CONTINUITY

Replace bulb and/or bulb socket.

CONTINUITY

2. Voltage

- Connect the pocket tester (DC20V) to the bulb socket coupler ①.

Tester (+) lead → Blue ② terminal
 Tester (-) lead → Black ③ terminal

- Start the engine.
- Check for voltage (12V) on the "Blue" lead at the bulb socket connector.

OUT OF SPECIFICATION

Wiring circuit from main switch to bulb socket connector is faulty, repair.

MEETS SPECIFICATION

This circuit is good.

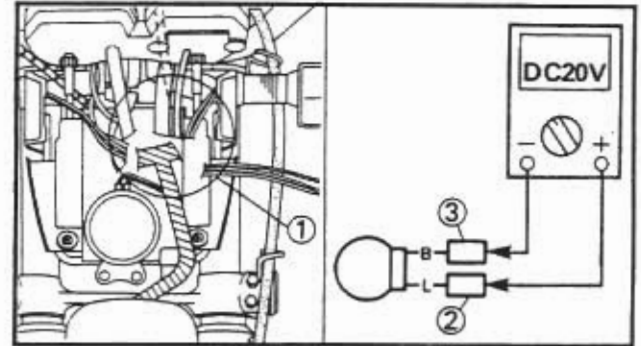



3. Taillight does not come on.

1. Bulb and bulb socket

- Check the bulb and bulb socket for continuity. Refer to the "CHECKING OF BULBS" section.

NO CONTINUITY

Replace bulb and/or bulb socket.

CONTINUITY

2. Voltage

- Connect the pocket tester (DC20V) to the bulb socket connector ①.

Tester (+) lead → Blue ② terminal
 Tester (-) lead → Black ③ terminal

- Start the engine.
- Check for voltage (12V) on the "Blue" lead at the bulb socket connector.

OUT OF SPECIFICATION

Wiring circuit from main switch to bulb socket connection is faulty, repair.

MEETS SPECIFICATION

This circuit is good.

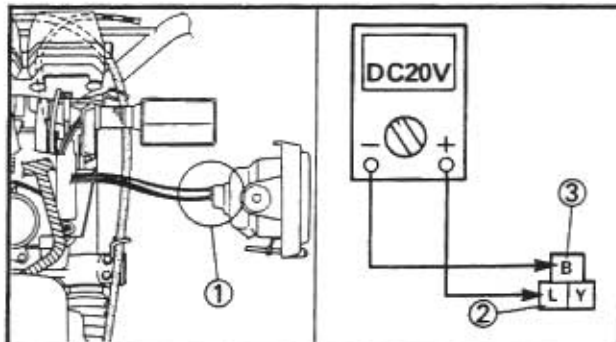



4. Auxiliary light does not come on.

1. Bulb and bulb socket

- Check the bulb and bulb socket for continuity. Refer to the "CHECKING OF BULBS" section.

NO CONTINUITY

Bulb and/or bulb socket are faulty, replace.

CONTINUITY

2. Voltage

- Connect the pocket tester (DC20V) to the bulb socket connector ①.

Tester (+) lead → Blue/Red ② lead
Tester (-) lead → Black ③ lead

- Start the engine.
- Check for voltage (12V) on the "Blue/Red" lead at the bulb socket connector.

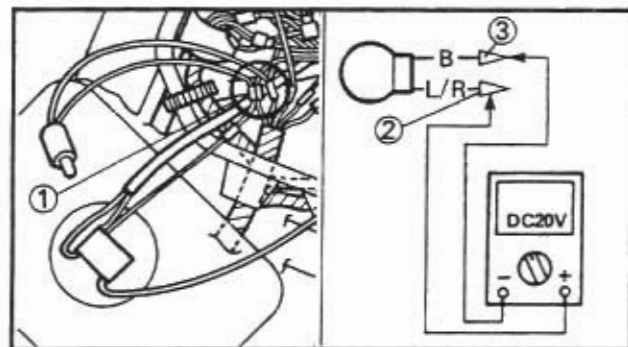

OUT OF SPECIFICATION

Wiring circuit from main switch to bulb socket connector is faulty, repair.

MEETS SPECIFICATION

This circuit is good.



SIGNAL SYSTEM
CIRCUIT DIAGRAM

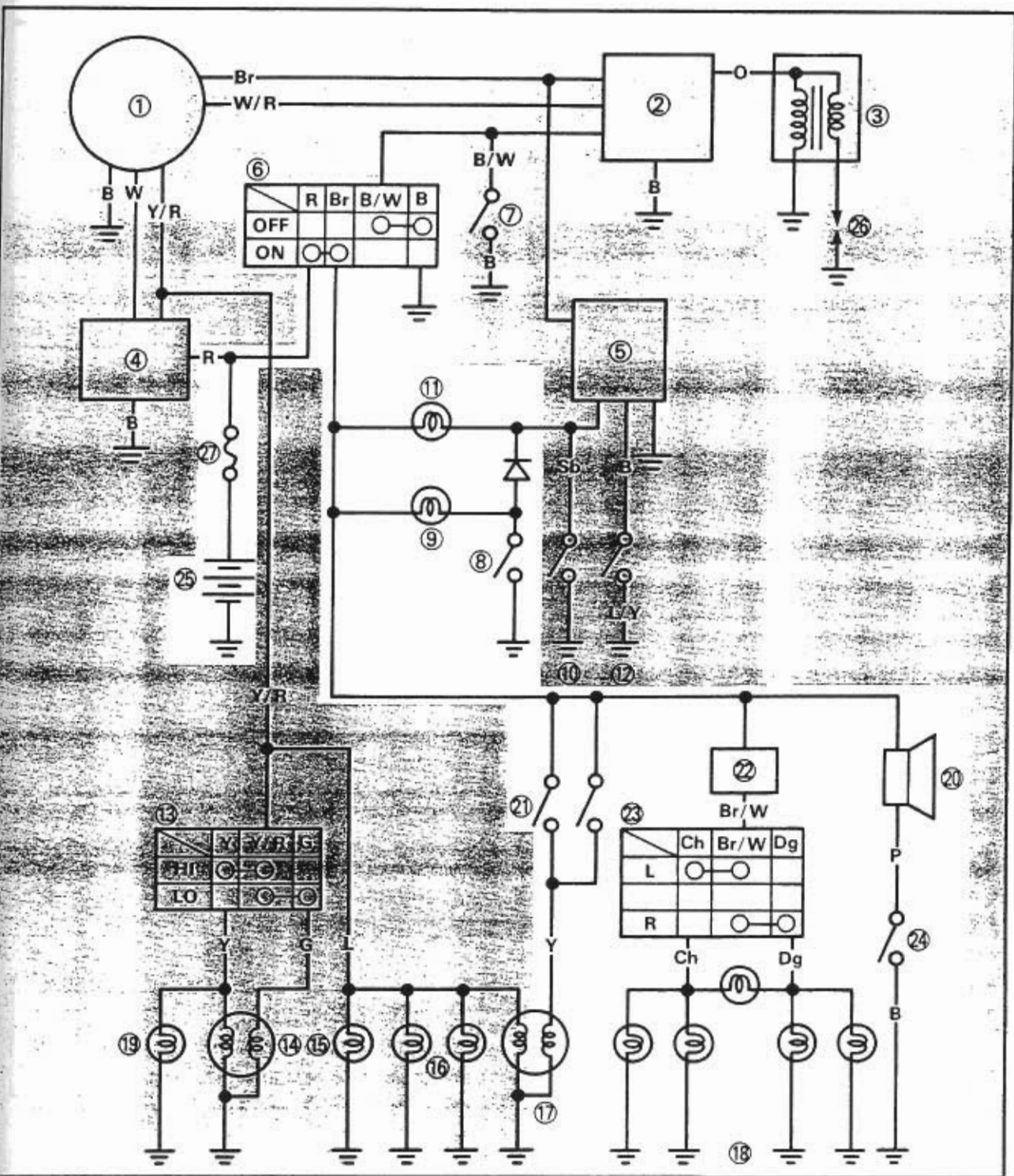

- | | |
|-----------------------------|-----------------------------|
| ⑥ Main switch | ⑪ "NEUTRAL" indicator light |
| ⑧ Oil level gauge | ⑫ "OIL" warning light |
| ⑨ "OIL" warning light | ⑬ Tail/Brake light |
| ⑪ "NEUTRAL" indicator light | ⑭ Flasher light |
| ⑬ Tail/Brake light | ⑮ Flasher light |
| ⑭ Flasher light | ⑯ Horn |
| ⑮ Flasher light | |
| ⑯ Horn | |



TROUBLESHOOTING

- FLASHER LIGHT, BRAKE LIGHT AND/OR INDICATOR LIGHT DO NOT COME ON.
- HORN DOES NOT SOUND.

Procedure

Check;

1. Fuse (main)
2. Battery
3. Main switch
4. Wiring connection (entire signal system)

NOTE:

- Remove the following parts before troubleshooting.
 - 1) Seat
 - 2) Side cover (left)
 - 3) Side cover (right)
- Use the following special tool in this troubleshooting.



Pocket tester:
P/N. 90890-03112

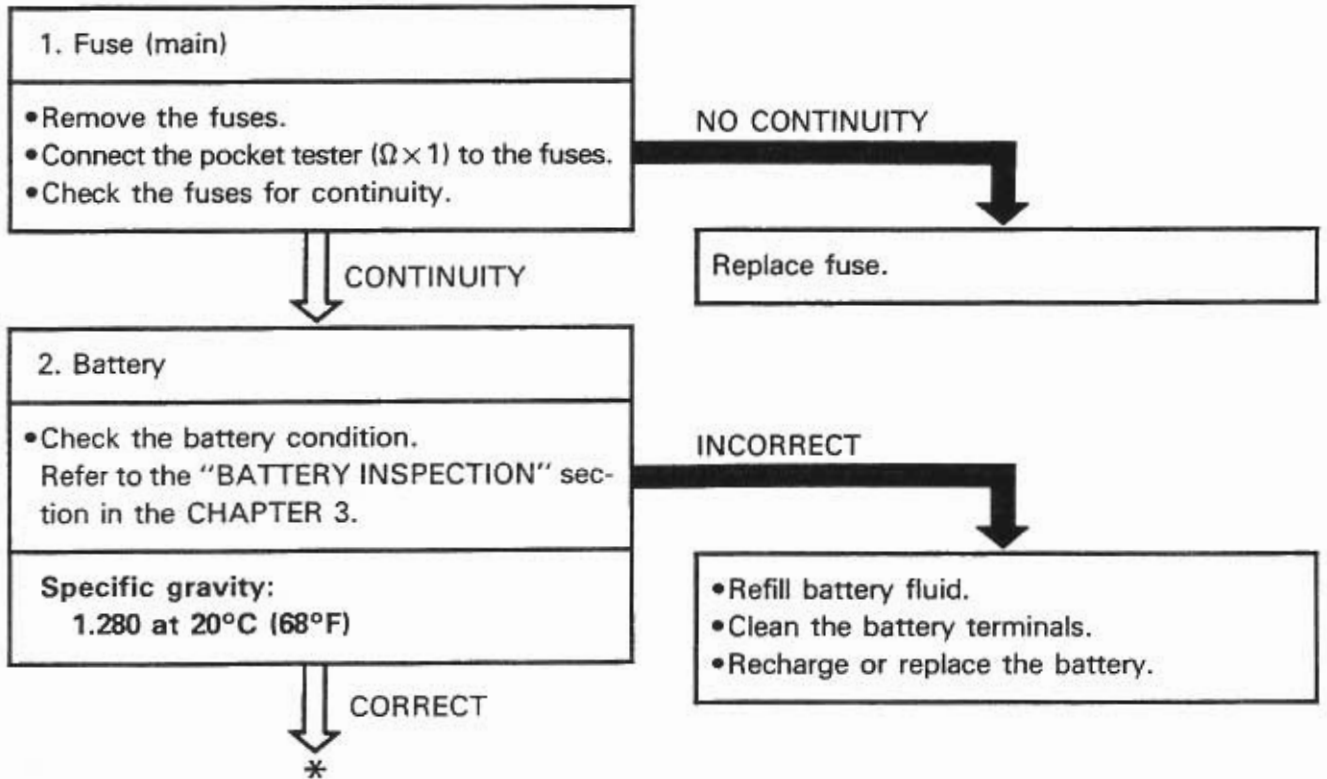



3. Main switch

- Disconnect the main switch coupler from the wireharness.
- Check the switch component for the continuity between "Red ① and Brown ②". Refer to the "CHECKING OF SWITCHES" section.

- Turn the main switch to "ON" and "OFF".
- Check the main switch for continuity.

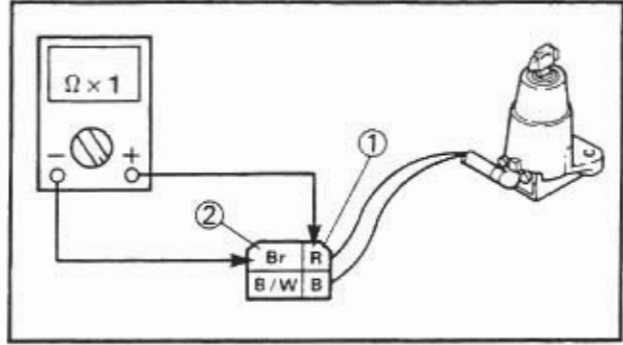

| Switch position | Good condition | Bad condition | | |
|-----------------|----------------|---------------|---|---|
| ON | ○ | × | × | ○ |
| OFF | × | ○ | × | ○ |

○: Continuity ×: Nocontinuity

INCORRECT

Replace main switch.

CORRECT

4. Wiring connection

- Check the entire signal system for connections. Refer to the "WIRING DIAGRAM" section.

POOR CONNECTION

Correct.

CORRECT

Check condition of each circuit for signal system. Refer to "SIGNAL SYSTEM CHECK" section.



SIGNAL SYSTEM CHECK

1. Horn does not sound.

1. "HORN" switch.

- Disconnect the handlebar switch (left) coupler ① from wireharness.
- Check the switch component for the continuity between "Pink ② and Black ③". Refer to the "CHECKING OF SWITCHES" section.

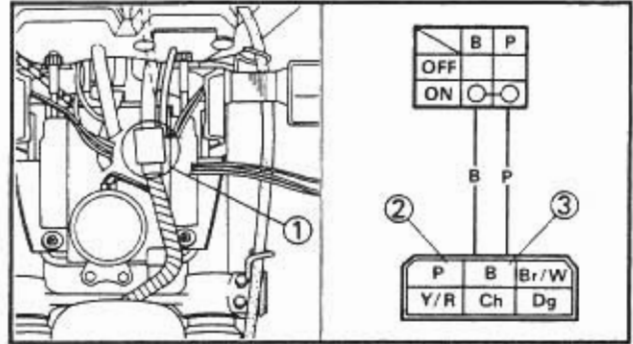

INCORRECT

Replace handlebar switch (left).

CORRECT

2. Voltage

- Connect the pocket tester (DC20V) to the horn lead.

Tester (+) lead → Brown ① lead
 Tester (-) lead → Frame ground

- Turn the main switch to "ON".
- Check for voltage (12V) on the "Brown" lead at the horn terminal.

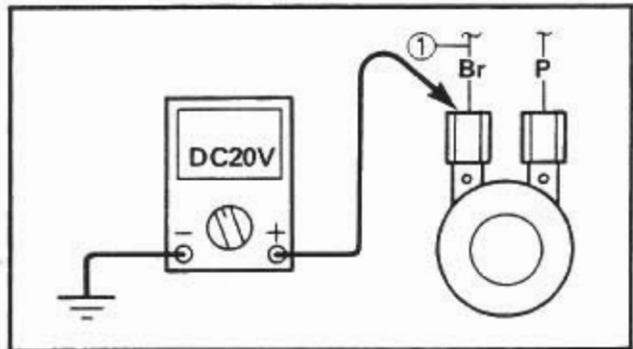

OUT OF SPECIFICATION

Wiring circuit from main switch to horn terminal is faulty, repair.

MEETS SPECIFICATION (12V)

*



3. Horn

- Disconnect the "Pink" lead from the horn terminal.
- Connect a jumper lead ① to the horn terminal and ground the jumper lead.
- Turn the main switch to "ON".

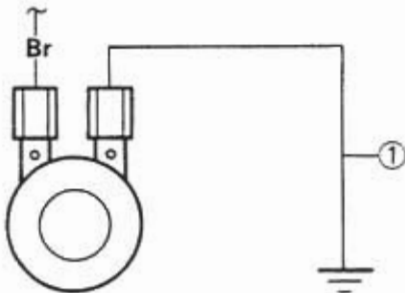

HORN IS SOUNDED

Horn is good.

HORN IS NOT SOUNDED

4. Voltage

- Connect the pocket tester (DC20V) to the horn at the "Pink" terminal.

Tester (+) lead → Pink ① lead
 Tester (-) lead → Frame ground

- Turn the main switch to "ON".
- Check for voltage (12V) on the "Pink" lead at the horn terminal.

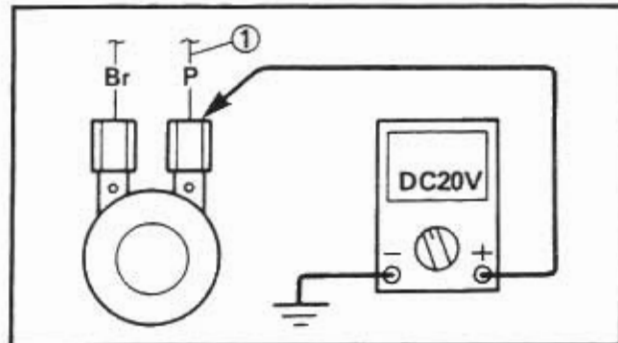

OUT OF SPECIFICATION

Horn is faulty, replace it.

MEETS SPECIFICATION (12V)

Adjust or replace horn.



2. Brake light does not come on.

1. Bulb and bulb socket

- Check the bulb and bulb socket for continuity. Refer to the "CHECKING OF BULBS" section.

CONTINUITY

NO CONTINUITY

Replace bulb and/or bulb socket.

2. Brake switch

- Disconnect the brake switch leads from the wireharness.
- Check the switch component for the continuity between "Black ① and Black ②". Refer to the "CHECKING OF SWITCHES" section.

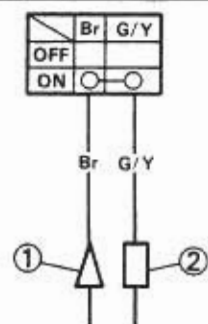
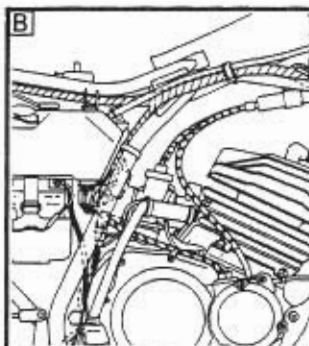
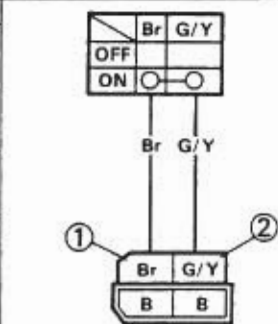
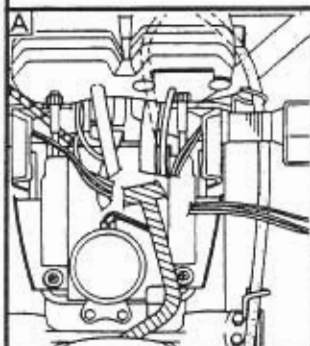

A Front brake switch
B Rear brake switch

INCORRECT

Replace brake switch.

CORRECT

3. Voltage

- Connect the pocket tester (DC20V) to the bulb socket connector.

Tester (+) lead → Green/Yellow ① lead
Tester (-) lead → Brown ② lead

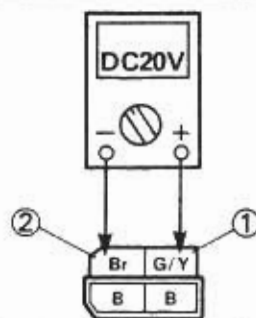



- Turn the main switch to "ON".
- The brake lever is pulled in or brake pedal is stepped down.
- Check for voltage (12V) on the "Green/Yellow" lead at the bulb socket connector.

MEETS SPECIFICATION (12V)

This circuit is good.

OUT OF SPECIFICATION

Wiring circuit from main switch to bulb socket connector is faulty, repair.

3. Flasher light and/or "TURN" indicator light does not blink.

1. Bulb and bulb socket

- Check the bulb and bulb socket for continuity. Refer to the "CHECKING OF BULBS" section.

NOCONTINUITY

Replace bulb and/or bulb socket.

CONTINUITY

2. "TURN" switch

- Disconnect the handlebar switch (left) coupler ① from the wireharness.
- Check the switch component for the continuity between "Brown/White ② and Chocolate ③" and "Brown/White ② and Dark green ④". Refer to the "CHECKING OF SWITCHES" section.

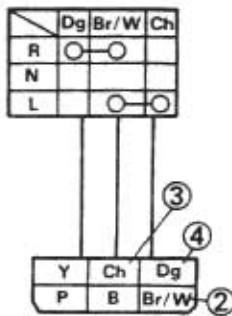
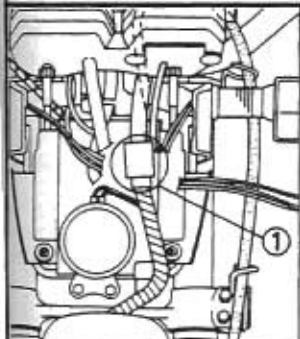

NOCONTINUITY

"TURN" switch is faulty, replace handlebar switch (left).

CORRECT

*



3. Voltage

- Connect the pocket tester (DC20V) to the flasher relay.

Tester (+) lead → Brown ① lead
Tester (-) lead → Frame ground

- Turn the main switch to "ON".
- Check for voltage (12V) on the "Brown" lead at the flasher relay terminal.

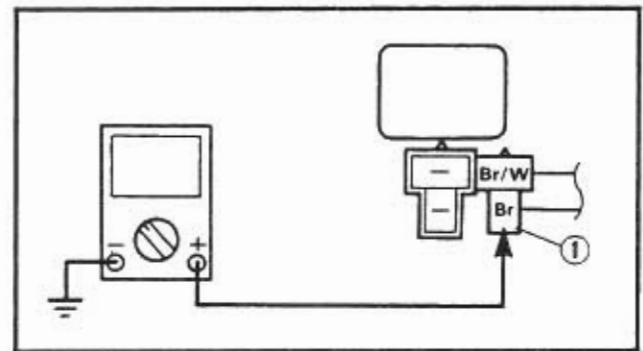

OUT OF SPECIFICATION

MEETS
SPECIFICATION (12V)

Wiring circuit from main switch to flasher re-
lay connector is faulty, repair.

4. Voltage

- Connect the pocket tester (DC20V) to the flasher relay.

Tester (+) lead → Brown/White ① lead
Tester (-) lead → Frame ground

- Turn the main switch to "ON".
- Check for voltage (12V) on the "Brown/White" lead at the flasher relay terminal.

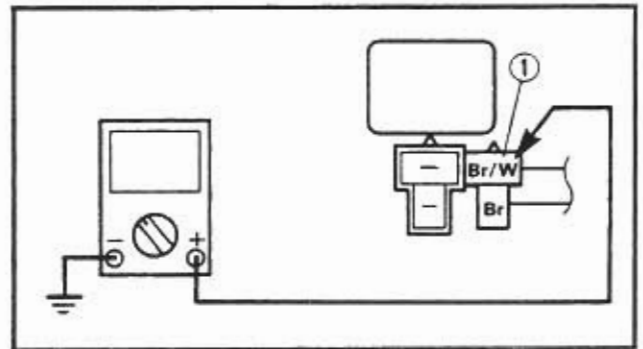

OUT OF SPECIFICATION

MEETS
SPECIFICATION (12V)

Flasher relay is faulty, replace it.

5. Voltage

- Connect the pocket tester (DC20V) to the bulb socket connector.

At flasher light (left):
Tester (+) lead → Chocolate ① lead
Tester (-) lead → Frame ground

At flasher light (right):
Tester (+) lead → Dark green ② lead
Tester (-) lead → Frame ground

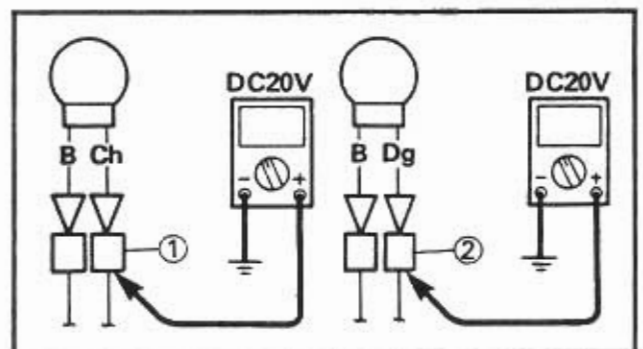



- Turn the main switch to "ON".
- Turn the "TURN" switch to "L" or "R".
- Check for voltage (12V) on the "Chocolate" lead or "Dark green" lead at the bulb socket connector.

MEETS SPECIFICATION (12V)

This circuit is good.

OUT OF SPECIFICATION

Wiring circuit from "TURN" switch to bulb socket connector is faulty, repair.

4. "NEUTRAL" indicator light does not come on.

1. Bulb and bulb socket
- Check the bulb and bulb socket for continuity. Refer to the "CHECKING OF BULBS" section.

NO CONTINUITY

Replace bulb and/or bulb socket.

CONTINUITY

2. Neutral switch
- Disconnect the neutral switch coupler ① from the wireharness.
 - Check the switch component for the continuity between "Sky blue ② and Ground". Refer to the "CHECKING OF SWITCHES" section.

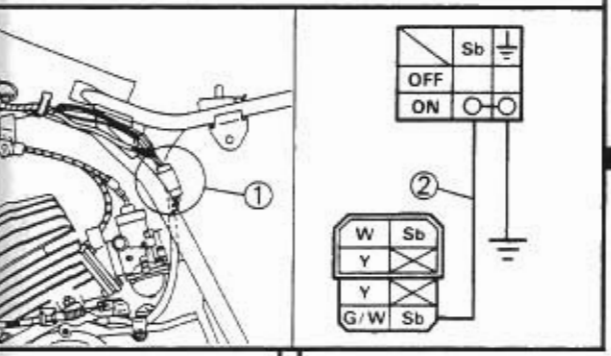

INCORRECT

Replace neutral switch.

CORRECT

3. Voltage
- Connect the pocket tester (DC20V) to the bulb socket connector.
- Tester (+) lead → Sky blue ① terminal
 Tester (-) lead → Brown ② terminal

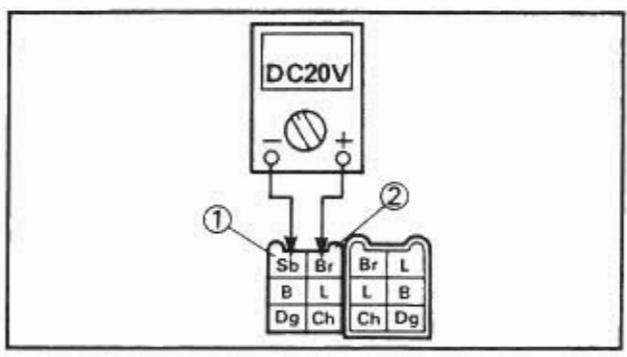

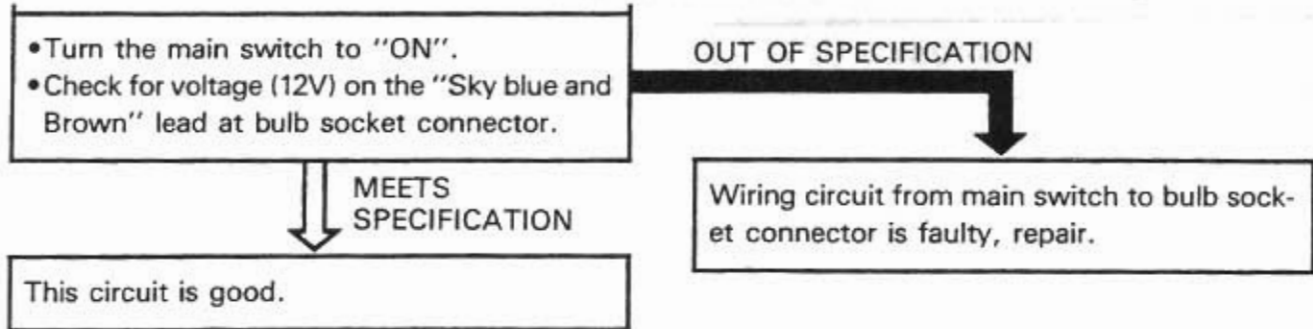

5. "OIL" indicator light does not come on.

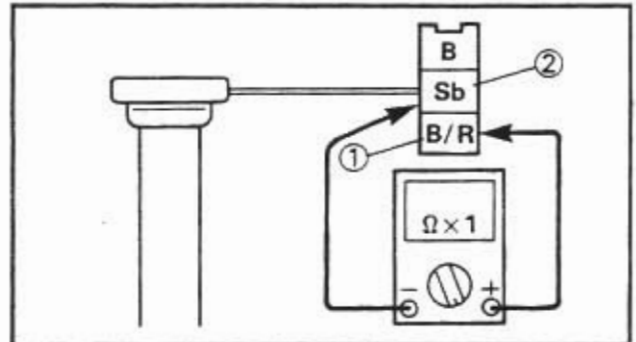
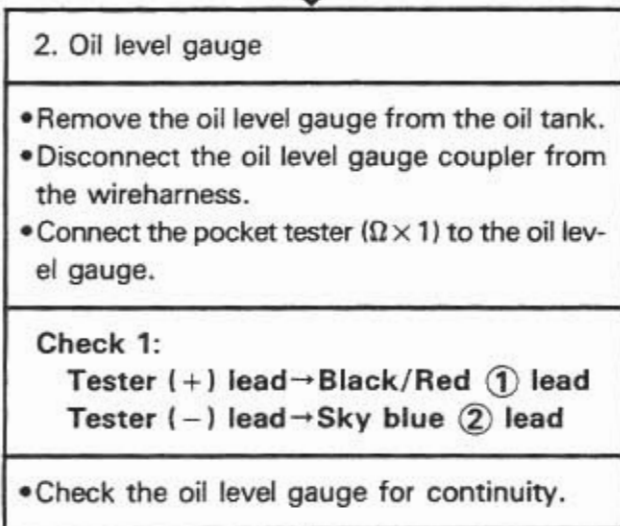
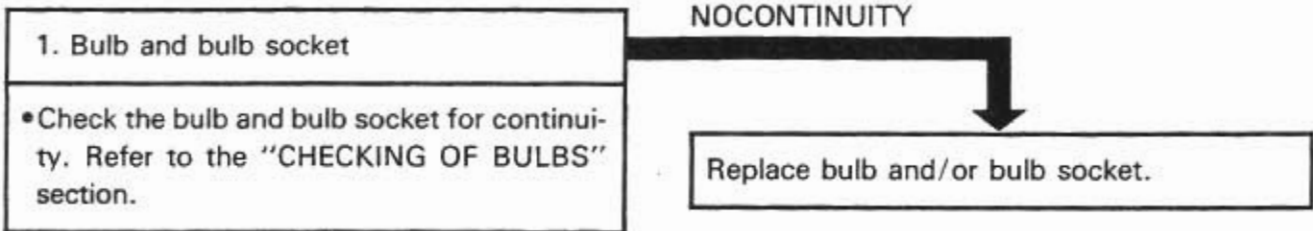



3. Oil level gauge

- Connect the pocket tester ($\Omega \times 1$) to the oil level gauge.

Check 2:
 Tester (+) lead \rightarrow Black/Red ① lead
 Tester (-) lead \rightarrow Black ② lead

- Check the oil level gauge for continuity.

| Switch position | Good condition | Bad condition | | |
|-----------------------|----------------|---------------|---|---|
| Upright position | ○ | × | × | ○ |
| Up-side down position | × | ○ | × | ○ |

○: Continuity ×: Nocontinuity

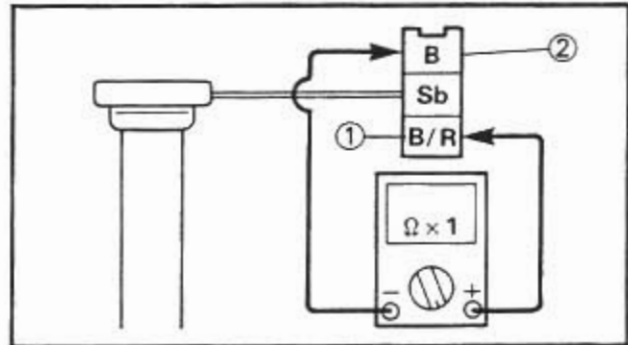

BAD CONDITION

Replace oil level gauge.



GOOD CONDITION

4. Voltage

- Disconnect the indicator light box coupler from the wireharness.
- Connect the pocket tester (DC20V) to the "OIL" indicator light coupler.

Tester (+) lead \rightarrow Black/Red ① lead
 Tester (-) lead \rightarrow Brown ② lead

- Check the "OIL" indicator light voltage.

"OIL" indicator light voltage:
 12.0V

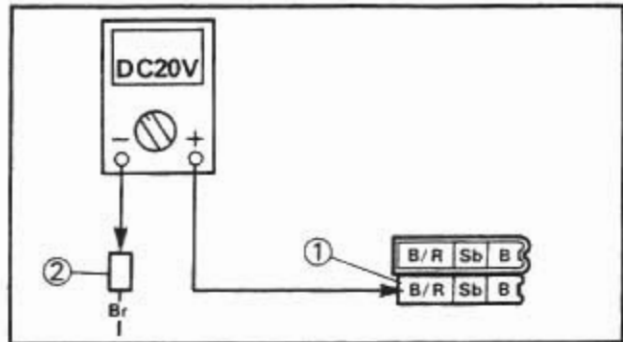

OUT OF SPECIFICATION

5. Wiring connection

Check the entire signal system for connections. Refer to the "WIRING DIAGRAM" section.



MEETS SPECIFICATION

This circuit is good.

CHAPTER 8. TROUBLESHOOTING

| | |
|--|------|
| STARTING FAILURE/HARD STARTING | I-10 |
| FUEL SYSTEM | I-10 |
| ELECTRICAL SYSTEM | I-10 |
| COMPRESSION SYSTEM | I-10 |
| POOR IDLE SPEED PERFORMANCE | I-11 |
| POOR IDLE SPEED PERFORMANCE | I-11 |
| POOR MEDIUM AND HIGH SPEED PERFORMANCE | I-11 |
| FUEL SYSTEM | I-11 |
| ELECTRICAL SYSTEM | I-11 |
| COMPRESSION SYSTEM | I-11 |
| FAULTY GEAR SHIFTING | I-11 |
| HARD SHIFTING | I-11 |
| SHIFT PEDAL DOES NOT MOVE | I-12 |
| JUMP-OUT GEAR | I-12 |
| CLUTCH SLIPPING/Dragging | I-12 |
| CLUTCH SLIPPING | I-12 |
| CLUTCH DRAGGING | I-12 |
| IMPROPER KICKING | I-12 |
| SLIPPING | I-12 |
| HARD KICKING | I-12 |
| KICK CRANK NOT RETURNING | I-12 |
| FAULTY BRAKE | I-12 |
| POOR BRAKING EFFECT | I-12 |
| FRONT FORK OIL LEAKAGE AND FRONT FORK MALFUNCTION | I-13 |
| OIL LEAKAGE | I-13 |
| MALFUNCTION | I-13 |
| INSTABLE HANDLING | I-13 |
| INSTABLE HANDLING | I-13 |
| FAULTY SIGNAL AND LIGHTING SYSTEM | I-14 |
| HEADLIGHT DARK | I-14 |
| BULB BURNT OUT | I-14 |
| FLASHER DOES NOT LIGHT | I-14 |
| FLASHER KEEPS ON | I-14 |
| FLASHER WINKS SLOWER | I-14 |
| FLASHER WINKS QUICKER | I-14 |
| HORN IS INOPERATIVE | I-14 |
| OVERHEATING | I-14 |
| OVERHEATING | I-14 |



TROUBLESHOOTING

NOTE: _____

The following troubleshooting does not cover all the possible causes of trouble. It should be helpful, however, as a guide to troubleshooting. Refer to the relative procedure in this manual for inspection, adjustment and replacement of parts.

STARTING FAILURE/HARD STARTING

| <u>FUEL SYSTEM</u> | <u>PROBABLE CAUSE</u> |
|--------------------|--|
| Fuel tank | <ul style="list-style-type: none"> • Empty • Clogged fuel filter • Clogged fuel tank cap • Deteriorated fuel or fuel containing water or foreign material |
| Fuel cock | <ul style="list-style-type: none"> • Clogged fuel hose |
| Carburetor | <ul style="list-style-type: none"> • Deteriorated fuel, fuel containing water or foreign material • Clogged pilot jet • Clogged pilot air passage • Sucked-in air • Deformed float • Groove-worn needle valve • Improperly sealed valve seat • Improperly adjusted fuel level • Improperly set pilot jet • Clogged starter jet • Starter plunger malfunction • Improperly adjusted starter cable |
| Air cleaner | <ul style="list-style-type: none"> • Clogged air filter |

ELECTRICAL SYSTEM

PROBABLE CAUSE

- Spark plug
 - Improper plug gap
 - Worn electrodes
 - Wire between terminals broken
 - Improper heat range
 - Faulty spark plug cap
- Ignition coil
 - Broken or shorted primary/secondary
 - Faulty spark plug lead
 - Broken body
- CDI unit system
 - Faulty CDI unit
 - Faulty source coil
 - Faulty pick-up coil
 - Broken woodruff key
- Switches and wiring
 - Faulty main switch
 - Faulty engine stop switch
 - Broken or shorted wiring
 - Faulty neutral switch
 - Faulty sidestand switch
 - Faulty ignition control unit

COMPRESSION SYSTEM

PROBABLE CAUSE

- Cylinder and cylinder head
 - Loose spark plug
 - Loose cylinder head or cylinder
 - Broken cylinder head gasket
 - Broken cylinder gasket
 - Worn, damaged or seized cylinder
- Piston and piston rings
 - Improperly installed piston ring
 - Worn, fatigued or broken piston ring
 - Seized piston ring
 - Seized or damaged piston
- Crankcase and crankshaft
 - Improperly seated crankcase
 - Improperly sealed crankcase (Damaged oil seal)
 - Seized crankshaft
- Reed valve
 - Deformed reed valve stopper
 - Improperly seated reed valve
 - Loose intake manifold
 - Broken gasket
 - Broken reed valve

POOR IDLE SPEED PERFORMANCE/ POOR MEDIUM AND HIGH SPEED PERFORMANCE

TRBL
SHTG ?

I.

POOR IDLE SPEED PERFORMANCE

POOR IDLE SPEED PERFORMANCE

Carburetor

PROBABLE CAUSE

- Improperly returned starter plunger
- Clogged or loose pilot jet
- Clogged pilot air passage
- Improperly adjusted idle speed (Throttle stop screw)
- Improper throttle cable play
- Faulty pick up coil

POOR MEDIUM AND HIGH SPEED PERFORMANCE

FUEL SYSTEM

PROBABLE CAUSE

Fuel tank

- Clogged fuel filter
- Deteriorated fuel or fuel containing water or foreign material
- Clogged fuel breather hose

Fuel cock

- Clogged fuel hose

Carburetor

- Deteriorated fuel, fuel containing water or foreign material
- Sucked-in air
- Deformed float
- Groove-worn needle valve
- Improperly sealed valve seat
- Improperly set clip position of jet needle
- Improperly adjusted fuel level
- Clogged or loose main jet
- Clogged or loose needle jet

Air cleaner

- Clogged air filter

ELECTRICAL SYSTEM

PROBABLE CAUSE

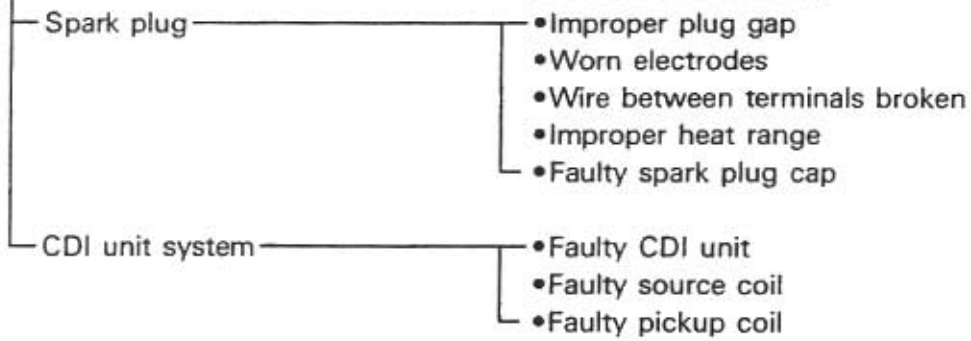

COMPRESSION SYSTEM

PROBABLE CAUSE

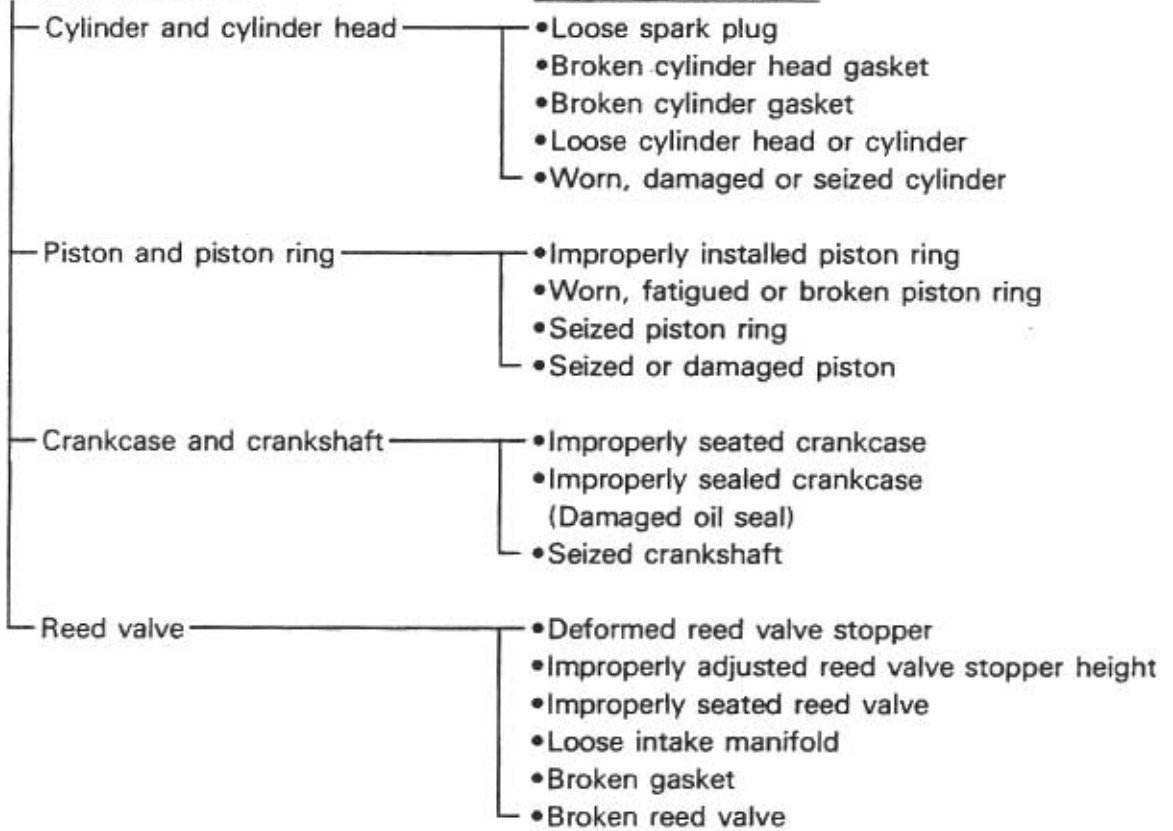

FAULTY GEAR SHIFTING

HARD SHIFTING

PROBABLE CAUSE

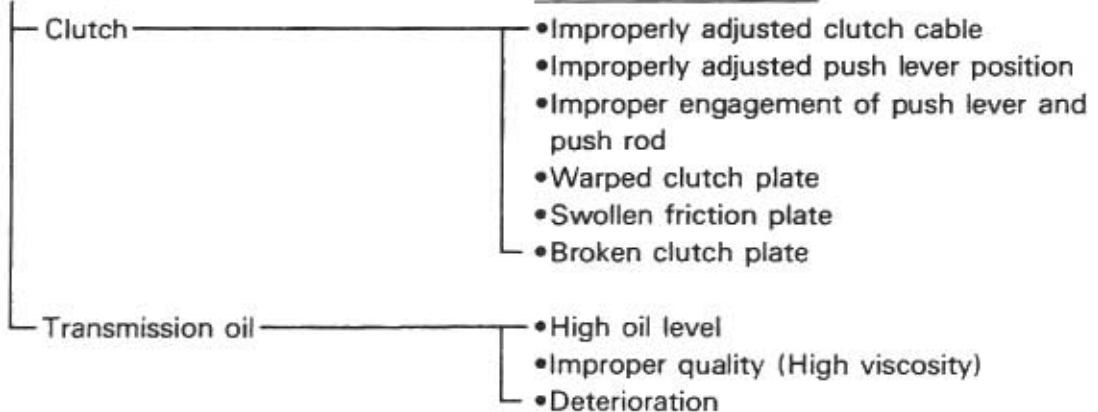

CLUTCH SLIPPING/Dragging

TRBL
SHTG ?

I-

SHIFT PEDAL DOES NOT MOVE

PROBABLE CAUSE

- Shift shaft ————— •Bent shift shaft
- Shift cam and shift fork —————
 - Groove jammed with impurities
 - Seized shift fork
 - Bent shift fork guide bar
- Transmission —————
 - Seized transmission gear
 - Jammed impurities
 - Incorrectly assembled transmission

JUMP-OUT GEAR

PROBABLE CAUSE

- Shift shaft —————
 - Improperly adjusted shift lever position
 - Improperly returned stopper lever
- Shift fork ————— •Worn shift fork
- Shift cam —————
 - Improper thrust play
 - Worn shift cam groove
- Transmission ————— •Worn gear dog

CLUTCH SLIPPING/Dragging

CLUTCH SLIPPING

PROBABLE CAUSE

- Clutch —————
 - Improperly adjusted clutch cable
 - Loose clutch spring
 - Fatigued clutch spring
 - Worn friction plate
 - Worn clutch plate
- Transmission oil —————
 - Low oil level
 - Improper quality (Low viscosity)
 - Deterioration

CLUTCH DRAGGING

PROBABLE CAUSE

- Clutch —————
 - Improperly adjusted clutch cable
 - Improperly adjusted push lever position
 - Improper engagement of push lever and push rod
 - Warped clutch plate
 - Swollen friction plate
 - Broken clutch boss
- Transmission oil —————
 - High oil level
 - Improper quality (High viscosity)
 - Deterioration

IMPROPER KICKING

SLIPPING

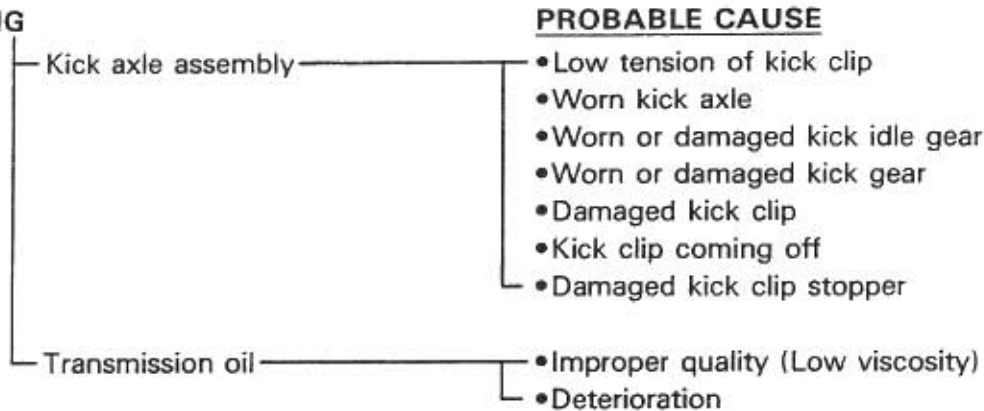

HARD KICKING

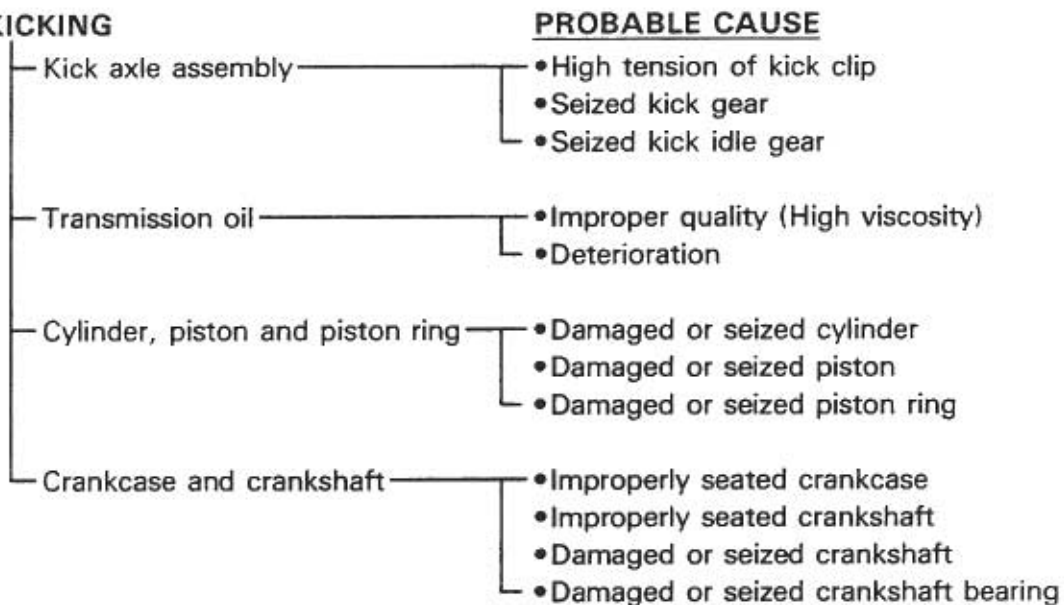

KICK CRANK NOT RETURNING

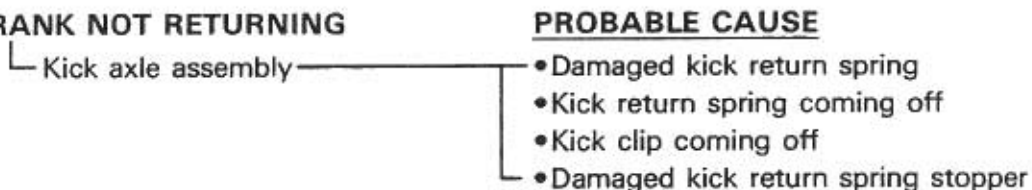

FAULTY BRAKE

POOR BRAKING EFFECT

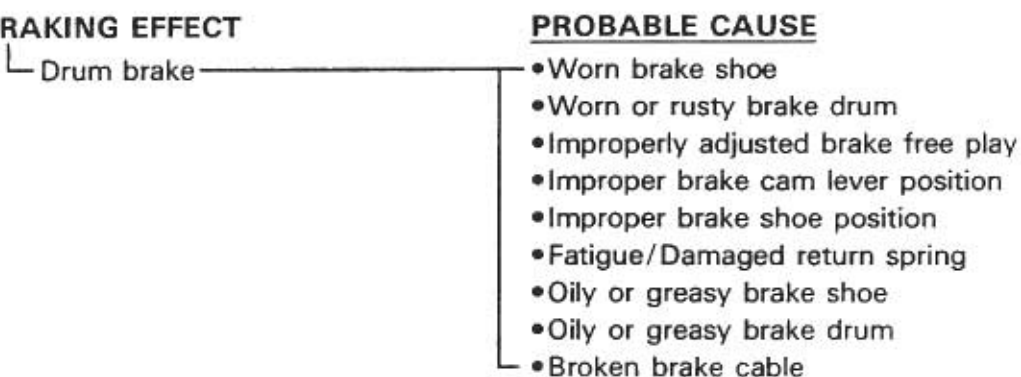

FRONT FORK OIL LEAKAGE AND FRONT FORK MALFUNCTION

| | |
|--------------|---|
| TRBL SHTG | ? |
|--------------|---|



FRONT FORK OIL LEAKAGE AND FRONT FORK MALFUNCTION

OIL LEAKAGE

PROBABLE CAUSE

- Bent, damaged or rusty inner tube
- Damaged or cracked outer tube
- Damaged oil seal lip
- Improperly installed oil seal
- Improper oil level (too much)
- Loose damper rod holding bolt
- Broken cap bolt O-ring
- Loose drain bolt
- Damaged drain bolt gasket

MALFUNCTION

PROBABLE CAUSE

- Bent, deformed or damaged inner tube
- Bent or deformed outer tube
- Damaged fork spring
- Worn or damaged slide metal
- Bent or damaged damper rod
- Improper oil viscosity
- Improper oil level

INSTABLE HANDLING

INSTABLE HANDLING

PROBABLE CAUSE

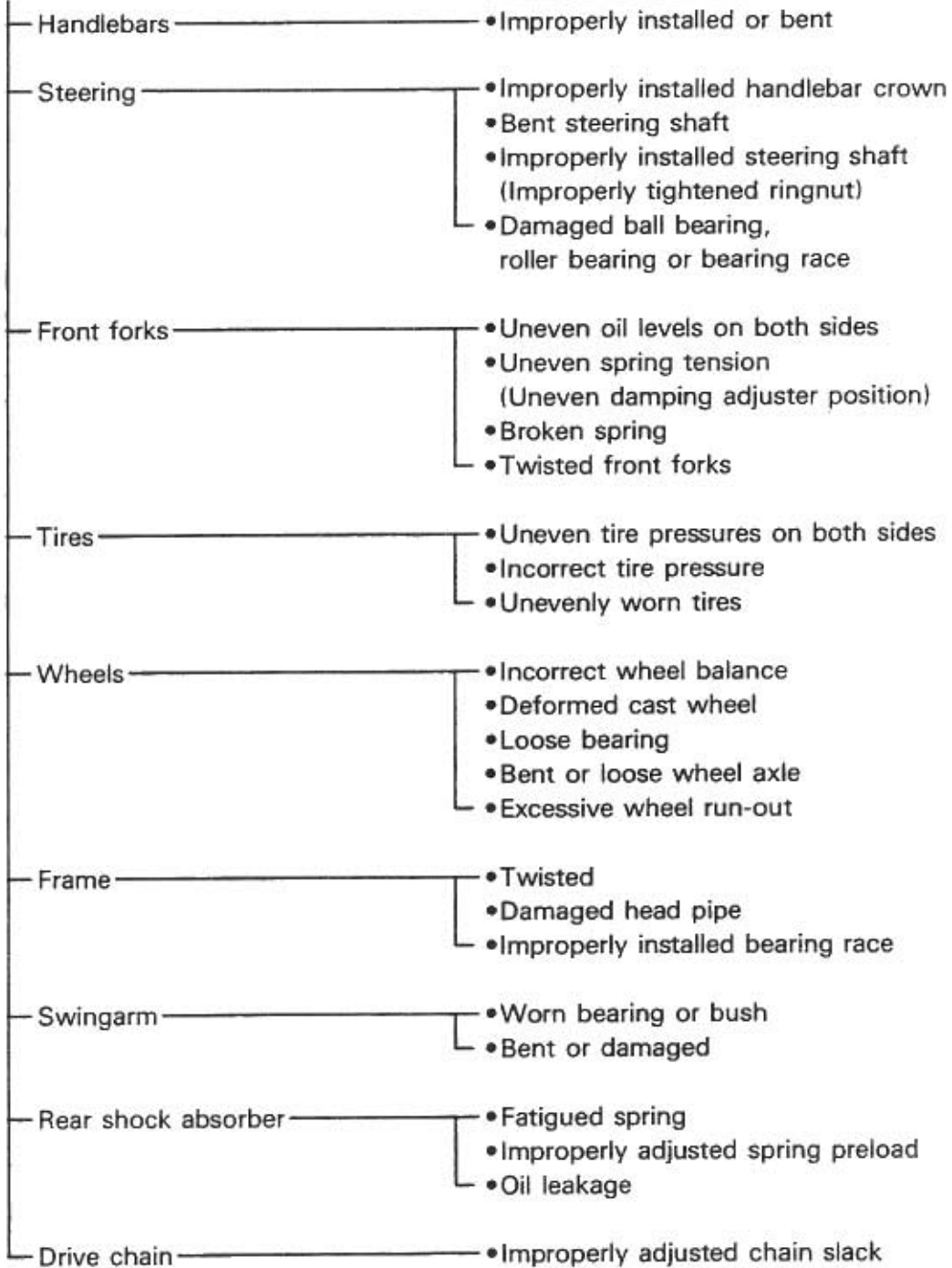

FAULTY SIGNAL AND LIGHTING SYSTEM

HEADLIGHT DARK

PROBABLE CAUSE

- Improper bulb
- Too many electric accessories
- Hard charging (Broken charging coil and/or faulty rectifier/regulator)
- Incorrect connection
- Improperly grounded
- Bulb life expired

BULB BURNT OUT

PROBABLE CAUSE

- Improper bulb
- Faulty battery
- Faulty rectifier/regulator
- Improperly grounded
- Faulty main and/or light switch
- Bulb life expired

FLASHER DOES NOT LIGHT

PROBABLE CAUSE

- Improperly grounded
- Discharged battery
- Faulty "TURN" switch
- Faulty flasher relay
- Broken wireharness
- Loosely connected coupler
- Bulb burnt out

FLASHER KEEPS ON

PROBABLE CAUSE

- Faulty flasher relay
- Insufficient battery capacity (nearly discharged)
- Bulb burnt out

FLASHER WINKS SLOWER

PROBABLE CAUSE

- Faulty flasher relay
- Insufficient battery capacity (nearly discharged)
- Improper bulb
- Faulty main and/or "TURN" switch

FLASHER WINKS QUICKER

PROBABLE CAUSE

- Improper bulb
- Faulty flasher relay

HORN IS INOPERATIVE

PROBABLE CAUSE

- Faulty battery
- Faulty main and/or horn switch
- Improperly adjusted horn
- Faulty horn
- Broken wireharness

OVERHEATING

OVERHEATING

PROBABLE CAUSE

- Ignition system
 - Improper spark plug gap
 - Improper spark plug heat range
 - Faulty CDI unit
- Fuel system
 - Improper carburetor main jet (Improper setting)
 - Improperly adjusted fuel height
 - Clogged air cleaner element
- Compression system
 - Heavy carbon build-up
- Engine oil
 - Incorrect oil level
 - Improper oil viscosity
 - Inferior oil quality
- Brake
 - Dragging brake

Yamaha DT 175

- når fornuft også gerne må være sjov...

Yamaha's DT 175 er en af efterkommerne efter Yamaha's DT 125 LC, der kom på markedet for ti år siden.

Oprindeligt er den udviklet til det australske og det afrikanske marked, hvor den for længst har bevist sin soliditet og sit værd.

Nu har DT 175'eren også fundet vej til de danske marked, hvor den takket været en fornuftig pris burde være den ideelle model for den, der har brug for et dagligt transportmiddel, der også skal kunne bruges til lidt sjov i fritiden.

Tekst: Steen S. Jørgensen

Foto: Liliana Roman



Yamaha DT 175 contra Citroën 2 CV: To hjul contra fire....

Starteren løfter flaget og signalerer dermed, at der nu er 30 sekunder til start. De to "piloter" sidder anspændte bag henholdsvis forude og styr: Nedtællingen er begyndt....

Vi befinder os midt i en klassisk match mellem to og fire hjul, det vil sige en accelerationsdyst mellem en motorcykel og en bil. "Fem, fire, tre, to, en - start!" I samme brøkdelt af det sekund, hvor flaget svinges, gives der fuld gas og koblingerne slippes: Racet er i gang.

De to køretøjer lægger fra land, og motorcyklen tager hurtigt tetén. Efter 18,9 sekunder passerer motorcyklen som den første kvartmilen, og udgangshastigheden noteres til 104 km/t. Langt bagude kommer bilen hølsende, og da den - omsider - passerer kvartmilen, holder motorcyklen allerede stille, og piloten har fået hjelm og handsker af. Sådan forløb vort eksperiment - et "drag-trip" - mellem Yamaha's nye lavprismodel, alias Yamaha DT 175, og en Citroën 2 CV. Og når vi ikke oplyser noget testresultat for 2 CV'en, skyldes det ganske enkelt, at vores afrivningskalender løb tør for blade, inden Citroën'en passerede målstregen....

Oprindeligt konstrueret til det australske marked

Yamaha DT 175 kom til Danmark i 1991 som ny lavprismodel. Således er det hensigten, at den skal tage arven op efter den så populære XT 250'er, der er ved at være udsolgt. Og prisen - kr. 21.999,00 - burde da også give DT 175'eren et par gode kort på hånden rent salgsmæssigt.

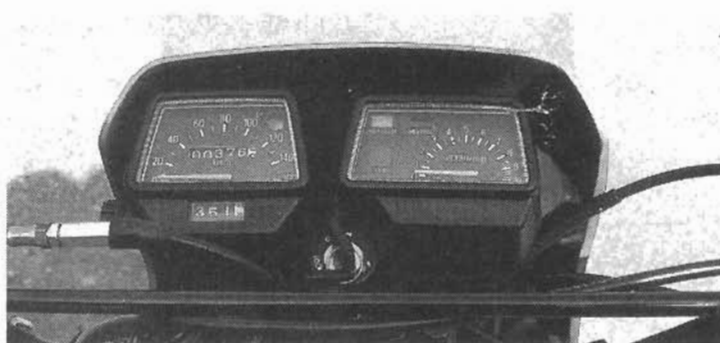

Instrumenteringen har, hvad den skal have, og takket været en olielampe i speedometeret bliver man advaret i god tid, inden man evt. løber tør for totaktsolie.



Forhjulet har 130 mm tromlebremse.



DT 175-motoren yder iflg. Yamaha's oplysninger 17,5 hk ved 7.000 rpm. Men oprindeligt er den konstrueret til en ydelse på 24,5 hk.

Nogen ny model er Yamaha DT 175 imidlertid ikke. Oprindeligt er den nemlig konstrueret til det australske marked, hvor den har haft stor succes. Det samme gælder i Afrika, hvor modellen - takket være dens lave pris, dens robuste opbygning og servicevenlighed - også har opnået stor popularitet.

Yamaha DT 175 er derfor en gennemprøvet model, der for længst har bevist sit værd - og det endda i dele af verden, hvor vejnettet er betydeligt mindre kultiveret end herhjemme. Som køber behøver man derfor ikke at frygte at

blive belemret med en model med en masse "børnesygdomme" eller for den sags skyld en model, der bare ikke kan klare "mosten".

Mange træk fælles med Yamaha's DT 125-motor

Konstruktionsmæssigt har Yamaha DT 175-motoren flere træk fælles med Yamaha's gamle DT 125 LC-motor. Ganske vist er DT 175-motoren luftkølet, mens Yamaha DT 125 LC-motoren er vandkølet. Men de to motorer har f.eks.

samme slaglængde (50,0 mm), og 175'erenes ekstra slagvolumen er skaffet til veje ved at øge boringen med 10,0 mm til 66,0 mm.

De to motorer har begge seks gear, og i flere gear har de samme udvekslingsforhold. Ligeledes udvekslingsforholdet i primærtransmissionen har de to til fælles. Endelig har de to motorer samme type karburator, og indsugningen går selvfølgelig gennem en membranventil.

Yamaha oplyser, at DT 175-motoren har 17,5 hk ved 7.000 rpm. Det lyder jo ganske pænt, men da vi overtog cyklen til



test, måtte vi konstatere, at i hvert fald en del af disse heste måtte være på græs. Motorens ydelse måtte nemlig mildest talt karakteriseres som beskednen. Eller som et medlem af vort testhold udtrykte det: "Den kører jo nærmest som en tunet knallert!"

Som regel er der altid en forklaring på den slags, og i dette tilfælde fandt vi forklaringen i udstødningen: Her var der en lille plombe øverst i udstødningen - lige ved udstødningsporten. Den bevirkede, at motoren kort og godt ikke kunne komme af med skidtet efter forbrændingen.

Ifølge oplysninger fra Yamaha Motor Denmark a/s betyder plomberingen, at DT 175-motoren kun yder 10,5 hk. Når plomben fjernes, yder motoren straks og uden yderligere ændringer 17,5 hk. At moto-

ren overhovedet er plomberet skyldes hensynet til visse oversøiske markeder, hvor afgifts- og forsikringsbetingel-

ser betyder, at motorcykler med mindre end 11 hk bliver særlig attraktive. Altså fjernede vi plomben, og

pludselig var det en anderledes sprælsk lille maskine, vi havde fået med at gøre. Nu var alle hestene pludselig kommet hjem i stalden.

Hos Yamaha Motor Denmark a/s oplyste man endvidere, at plomben iøvrigt altid fjernes i forbindelse med cyklens første service-eftersyn. At man - som regel - ikke fjerner den tidligere, skyldes at plomberingen er med til at sikre en mere "besindig" tilkørsel - og dermed en længere levetid for motoren efterfølgende.



Forlygten er i tilfælde af styrt godt beskyttet af den lille styrkåbe, men man savner et par ekstra watt, når det bliver rigtig mørkt...

24,5 hk indenfor rækkevidde

Senere drøftede vi modellen og dens ydeevne med Paul Kierstein fra Fa. Franz Kroons eftflg, Århus, der som bekendt er en af Danmarks førende Yamaha-forhandlere. Paul Kier-



YAMAHA
— det' lige os

Med danmarks største reservedelslager til unge og gamle Yamaha'er

VI VIL VÆRE NR. 1 NÅR DET GÆLDER KVALITET OG SERVICE

Derfor har vi også kvalitetsprodukterne inden for tilbehør og beklædning.

Postordre sendes fra dag til dag.

Stort aut. Yamaha værksted med erfarne Yamaha mekanikere.



— din garanti

HELE DANMARKS SPECIALBUTIK ligger i Århus. Størst med YAMAHA... bedst med kvalitet og service

Kom og besøg os - og gør en god handel

FRANZ KROON'S EFTF.

Nørrebrogade 2, 8000 Århus C, Tlf. 86 13 15 77

Progress A/S - 56 63 12 00

HONDA KAWASAKI

P.C. Motorcykler

SUZUKI YAMAHA

REP. & SERVICE

Tlf: 42 35 47 19 Fax: 42 35 47 59

Dette er kun et udpluk af vores sortiment:

DRIVER

boeri

HELMET

SHOEI

42 35 47 19

ELISAGÅRDSVEJ 6. 4000 ROSKILDE

Silkolene

LUBRICANTS

MOTUL

MOTOR OIL

DICKKAMIS

Jaguar lædertøj

TILBEHØR

Arai

HELMET.

MICHELIN

METZELER

DUNLOP

Komplet pakningsset

Forgaffelpakdåser

Batterier

Oljeprodukter

koblingsplader

KONI støddæmpere

Forstærkede koblingsfjedre

Kronrørsløjer

Koniske rullelejer

Bremseklodder

Luftfiltre

RK kæder

kædehjul

Kædekat

Oliefilter

Platiner

NGK tændrørshætter

Cylinder opborring

Vi udvider konstant vores varesortiment.

DENSO Ring og hør nærmere

SPARK PLUGS

stein mente nok, at der kunne hentes lidt ekstra kræfter ud af motoren: Og efter at han havde foretaget yderligere et par kunstgreb i udstødningen, var DT 175-motoren igen et helt nyt og endnu mere spændende bekendtskab.

En ny forespørgsel hos Yamaha Motor Denmark a/s afslørede da også, at DT 175-motoren oprindeligt er "designet" til en ydelse på 24,5 hk. Når den kun leveres herhjemme med de før omtalte 17,5 hk, skyldes det hensynet til støjkravene. Det må da også konstateres, at de senest tilkomne heste vrinsker lidt halvhøjt. Og da DT 175'eren kun er typegodkendt med de omtalte 17,5 hk - og det støjniveau som motoren har ved denne ydelse - vil hverken importør eller værksted garantere for noget, hvis man som DT 175-

ejer forsøger sig med ydelser ud over de 17,5 hk. Glemmes må det heller ikke, at øges ydelsen på en motor med mere end 20%, skal køretøjet til syn! Samtidig måtte vi også konstatere, at den sidste del af tuningen iøvrigt betød, at benzinförbruget steg mærkbart. Det gamle ord om, at intet er gratis, kom derfor igen til sin ret.

Det er ikke kun på motorsiden, at Yamaha DT 175 har træk fælles med den første model DT 125 LC. Også chassis, hjul og bremses minder på de to modeller meget om hinandens. Begge modeller har således enkelt lukket rørstel med teleskopgaffel for og monocross-affjedring bag.

Og præcis som den første DT 125 LC-model har Yamaha DT 175 130 mm tromlebremser

på begge hjul. Bagbremsen lever op til forventningerne, men forhjulsbremsen savner til gengæld kræfter, når man kommer ud på asfalten. Det gælder i særdeleshed ved den ydelse, man opnår, når man har "pillet" lidt for meget ved udstødningen!

Til gengæld matcher både for- og bagbremse fint på grusvej eller andet løst underlag. Begge bremses er nemlig nemme at dosere, og man lærer hurtigt at udnytte dem maksimalt - uden af den grund at risikere styrt p.g.a. blokeringer.

God kørestilling til solo

Selv om Yamaha DT 175 ikke er nogen stor motorcykel, har langt de fleste af nordisk statur alligevel nemt ved at finde

sig til rette på den. Sædet er nemlig tilpas langt til, at man uden besvær kan rykke frem eller tilbage, indtil man har fundet den rette position. Styr og fodhvilere er samtidig anbragt således, at både ben- og armstilling bliver fornuftig, og som på andre off-road'ere sidder man ret oprejst. Derved får man et godt overblik over omgivelserne i almindelighed og trafikken i særdeleshed. Ikke mindst sidstnævnte betyder, at DT 175'eren bliver suveræn i bytrafikken, hvor man lynhurtigt lærer at sno sig ud og ind mellem køerne af holdende biler og busser. Eller sagt med andre ord: Man skal lede længe, hvis man i dag skal finde et køretøj, der er ligeså effektivt i bytrafikken som en Yamaha DT 175. Og helt sikkert er det, at man ikke finder noget til samme pris!



På landevej klarer DT 175'eren sig også rimeligt, og man holder relativt nemt en marchhastighed på omkring de 80 km/t, som er tilladt herhjemme. Men stiv modvind og lange bakker bryder modellen sig ikke synderligt om. Ved møde med den slags forhindringer samt ved overhalinger må man vænne sig til at gøre brug af gearpedalen – og så iøvrigt bruge den tid der skal til.

Meget handy – blandt andet p.g.a. lav egenvægt

En Yamaha DT 175 vejer kun 98 kg. Det er ikke meget, og den lave egenvægt betyder, at cyklen bliver meget nem at håndtere – både på asfalt og i terræn.

På asfalt udmærker DT 175'eren sig ved at have fin retningsstabilitet, ligesom den iøvrigt styrer glimrende. Man lærer hurtigt at lægge den ned i svingene i vinkler, som betyder, at støvlesnuderne skraber. Og alt sammen virker det helt ufarligt, fordi cyklen er så handy og let.

I terræn klarer DT 175'eren sig også fint, og dens affjedring er tilpas "motocross-agtig" til, at man også kan muntre sig på bane. F.eks. klarer DT 175'eren nemt både mindre hop med efterfølgende landinger og ture gennem vandhuller. Og har man lyst til at skyde genvej over en pløjemark, ja, så giver det heller ikke de store problemer – hvis man vel at mærke er klædt på til en sådan spas....

Sidst og ikke mindst skal det fremhæves, at modellen er

konstrueret så fornuftigt, at den også kan klare i hvert fald mindre styrt i terrænet. Alle sårbare dele er gemt bedst muligt af vejen, og i tilfælde af styrt vil man ofte kunne rejse modellen og køre videre, som om intet var hændt.

Til fritid og transport

Udstyrmæssigt markerer Yamaha DT 175 sig først og fremmest ved at have en fin instrumentering med speedometer, omdrejningstæller og alle nødvendige kontrollamper, herunder en lampe der fortæller, når der skal hældes olie på olietanken.

Instrumenteringen er således bedre, end den man finder på mange større og dyrere modeller. Til gengæld må det konstateres, at køreløset kun-

ne have været bedre. Forlygten er ganske enkelt ikke kraftig nok, men omvendt er den tilstrækkelig kraftig til, at man kan klare sig. Og hastigheden kan og skal man jo altid afpasse efter forholdene.

Alt i alt er Yamaha DT 175 et godt køb for ham/hende, der har brug for et billigt og driftsikkert køretøj, som skal kunne anvendes til daglig transport – evt. suppleret med lidt sjov i fritiden. Det er modellen, som man kommer hurtigt frem på i myndretiden, og som det fremgår af indledningen, er DT 175'eren også sine firehulede konkurrenter overlegen præstationsmæssigt. Og samtidig er DT 175'eren også modellen, der kan magte lidt sjov i terræn – eller sagt på en anden måde: En motorcykel til ca. 80% fornuft og ca. 20% sjov.... ■

Yamaha DT 175:

Tekniske data og præstationer:

Motor:
Encylindret totaktsmotor med membranventilstyret indsugning.
Luftkølet. Autolube-smøring.
Boring x slaglængde: 66,0 x 50,0 mm.
Slagvolumen: 171 cc.
Kompression: 6,7 : 1.
Ydelse: 17,5 hk ved 7.000 rpm.
Max. drej.moment: 1,3 kg/m ved 6.000 rpm.

Benzintilførsel:
Enkelt VM 24 mm Mikuni-karburator.

Transmission:
Primærtræk over tandhjul. Flerplade-kobling i oliebad. Sekstrins gearkasse. Kædetræk til baghjul.

Udveksling:
1. gear: 3.181.
2. gear: 1.933.
3. gear: 1.368.
4. gear: 1.090.

5. gear: 0,956.
6. gear: 0,840.

Primæruvveksling: 3,227.
Sekundæruvveksling: 3,062.

El-anlæg:
Batteri: 12 volt, 3 ampere (1992-model).
(6 volt, 6 ampere på 1991-modellen).
Max. generatoreffekt: Ikke oplyst.
Bilux-forlygte, 35/35 watt standard.
Kontaktløs transistortænding.
Kick-start.

Stel m.m.:
Enkelt lukket rørstel, stål.
Kronrørsvinkel: ... 60,6 grader.
Efterløb: 123 mm.
Hydraulisk teleskopgaffel for, Max. vandring: 180 mm.
Monocross-affjedring med enkelt centralt placeret hydraulisk støddæmper med justerbar fjeder-spænding bag, Max. vandring: 150 mm.

Hjulstørrelse:
For: 2,75 x 21.
Bag: 4,10 x 18.
Dæk mærke: Bridgestone.
Eger-hjul.

Bremser:
For: Tromle, mekanisk aktiveret, Diameter: 130 mm.
Bag: Tromle, mekanisk aktiveret, Diameter: 130 mm.

Vægt m.v.:
Tørvægt: 98 kg.
Tankkapacitet: 9,5 liter.
Olietankkapacitet: 0,9 liter.

Speedometerfejlvkning:
Speedometer- Faktisk hastighed:
50 km/t: 47 km/t.
0 km/t: 75 km/t.
100 km/t: 93 km/t.

Km-tæller-fejlvkning: 4,5% for meget.

Vægt-/ydelsesforhold:
5,6 : 1.

Acceleration:
0-50 km/t: 3,2 sek.
0-60 km/t: 4,5 sek.
0-70 km/t: 6,2 sek.
0-80 km/t: 8,2 sek.
0-90 km/t: 11,2 sek.
0-100 km/t: 16,1 sek.

Kvartmile, stående: ... 18,9 sek.
Udgangshastighed: ... 104 km/t.

Tophastighed:
Siddende: 101 km/t.
Liggende: 110 km/t.

Benzinforbrug:
80 km/t: 19,9 km pr. liter.
Testforbrug: ... 16,3 km pr. liter.

Benzinkvalitet:
Oktankrav: Min. 91 oktan + blyfri benzin.

Priser:
Excl. reg.afgift: ... 11.181,00 kr.
Incl. reg.afgift: ... 21.999,00 kr.

Importør:
Yamaha Motor Denmark a/s,
5250 Odense S.
Tlf: 65 95 95 00.